

# CFW500 Machinery Drives

## Variable Speed Drives

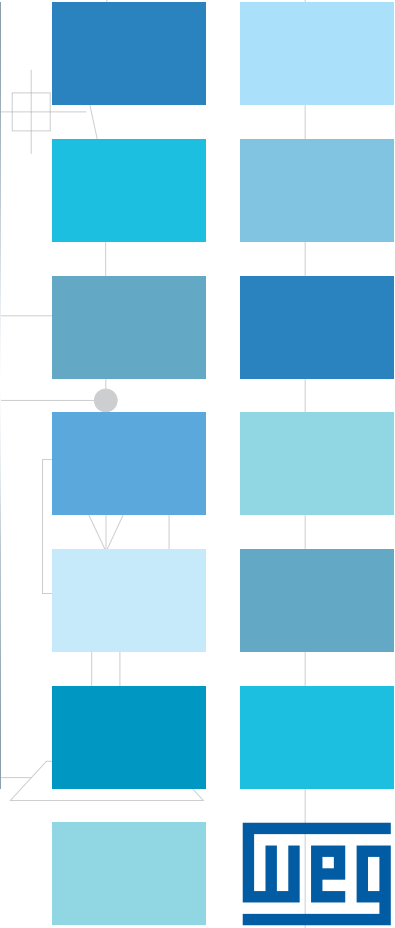
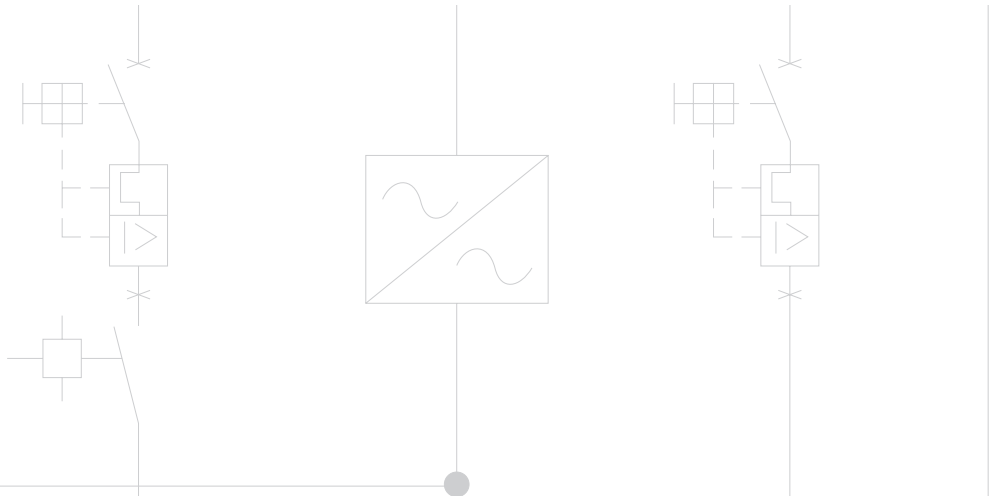

# CFW500

## One VSD, endless possibilities

Developed for fast commissioning, the CFW500 VSD is perfect for machines. Extremely compact and cost-effective, it fulfills the needs of machine manufacturers, integrated systems, panel installers and users for a wide range of applications.

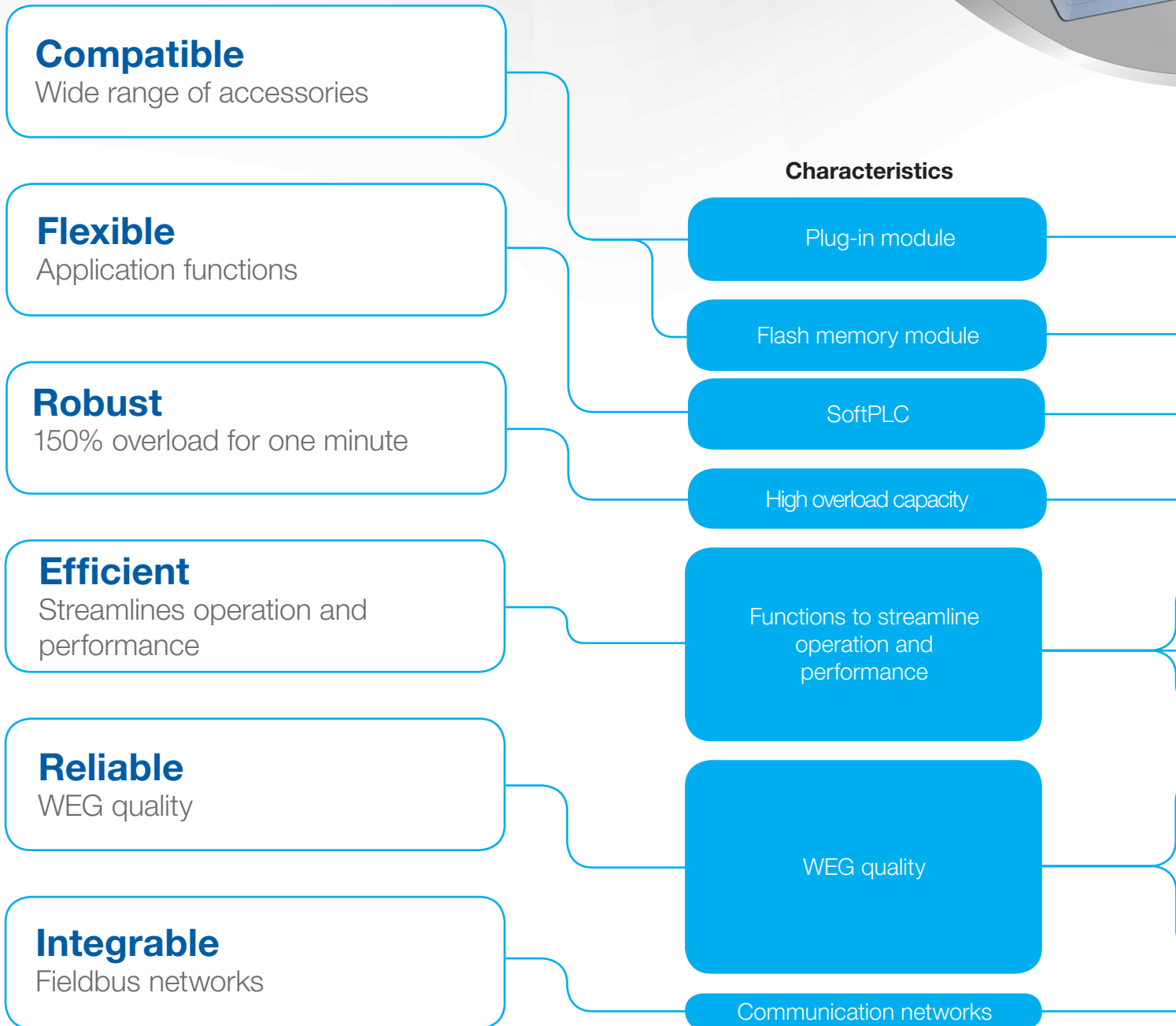
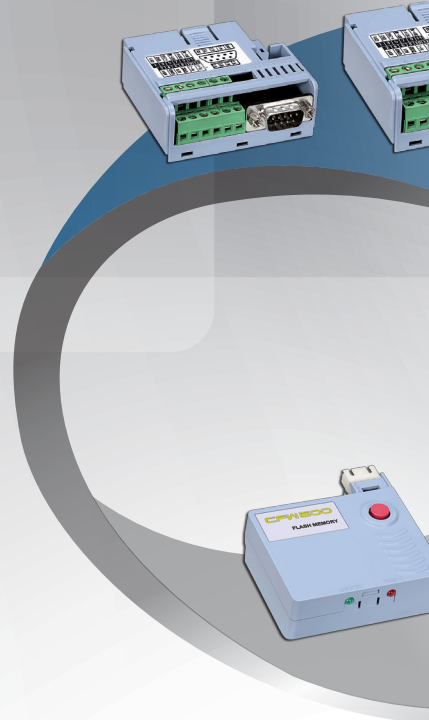



### Advantages

### Benefits

The optional communication network and I/O modules are fast and easily installed, allowing adapting the standard VSD to each application.

In few seconds, it is possible to download the programming from a CFW500 to others without powering them up.

Built-in PLC, enabling the VSD, motor and application to work in an interactive way. It allows the user to implement customized logics and applications.

It withstands an overload of 150% for one minute every 6 minutes, on ambient temperature of 50 °C.

PID: process control.  
Sleep: disables the VSD automatically.

Flying start: allows driving the motor that is in free spinning, accelerating it from the speed at which it was running.

Ride through: keeps the VSD in operation during voltage dips.

100% of the VSDs are tested with load at the factory under rated conditions.

Protection against ground fault, short circuit, over temperature and others.

Thermal protection of IGBTs based on manufacturer curve.

All the electronic boards are conformally coated.

CANopen, DeviceNet, Profibus-DP and Modbus.

Time saving, standardization and optimized costs according to the needs.

Fast, easy and reliable programming for manufacturers that produce machines in large quantities.

It eliminates the need of an external PLC, reducing costs, optimizing space and simplifying the system.

It does not require oversizing the VSD.

Energy saving.

It enables fast operating response of the machine and prevents occasional mechanical breakdowns.

It prevents machine stoppage and downtime.

High reliability.

It prevents damages to the inverter which can be caused by adverse situations, normally external factors.

VSD lifespan is extended: protection against dust, humidity, high temperatures and chemicals.

Full integration with process network.

# Easy Configuration

- Fast commissioning
- Innovative design, compact and uniform
- Configurable cost x benefit

### Plug-in Modules

Connections and interfaces at your hands.

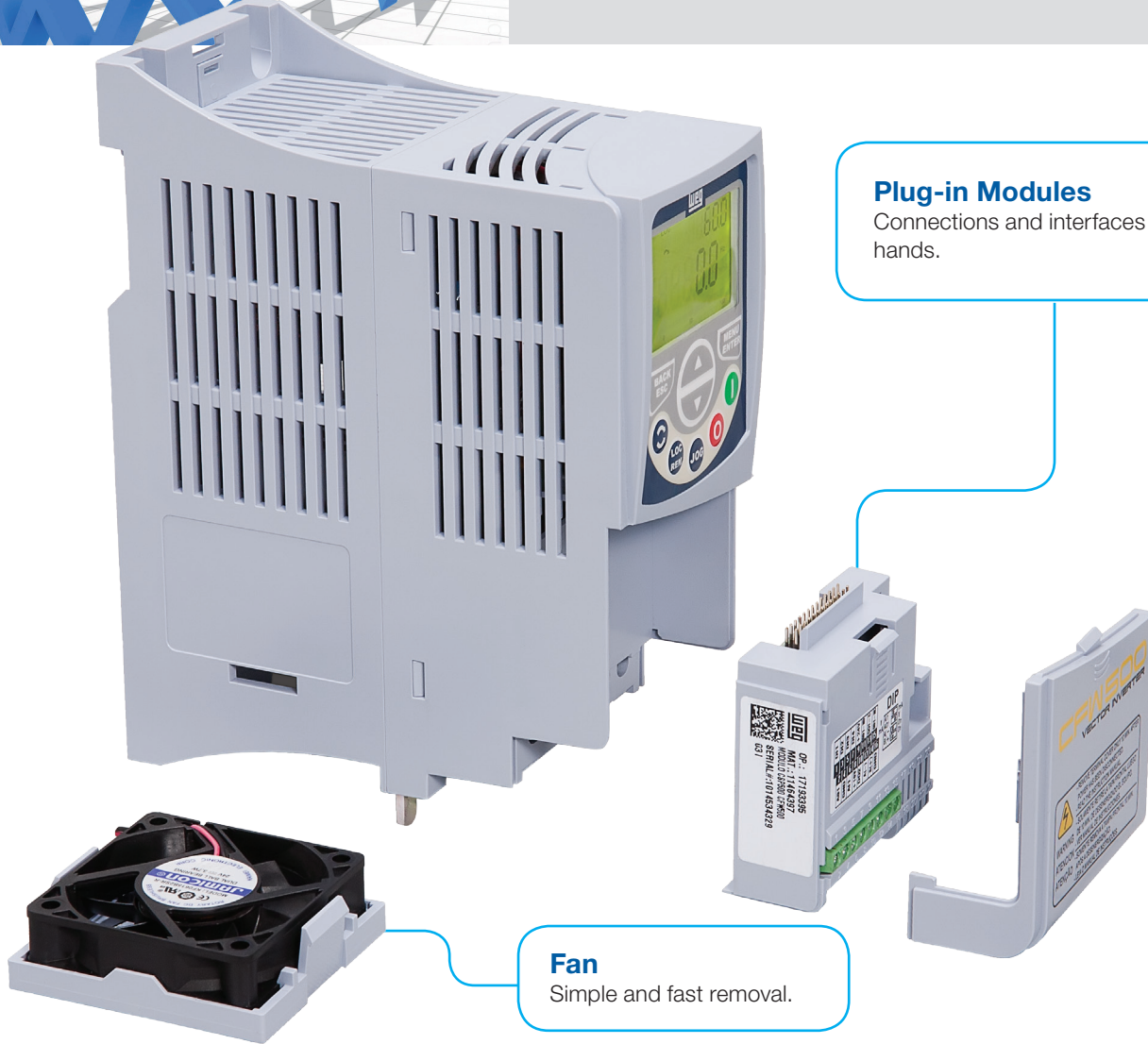

**Fan**  
Simple and fast removal.

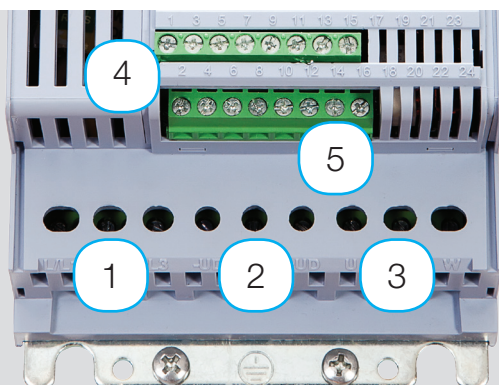

### With plug-in module CFW500-IOS

- 1 - Power terminals
- 2 - Access to DC link
- 3 - Motor terminals
- 4 - Control terminals (I/Os)
- 5 - RS485 port



## Applications

- Centrifugal pumps
- Process dosing pumps
- Fans / exhausters
- Stirrers / mixer
- Compressors
- Conveyor belts
- Roller tables
- Granulators / palletizers
- Dryers
- Rotary filters



# Human-Machine Interface

- View of three parameters at the same time, selected by the user

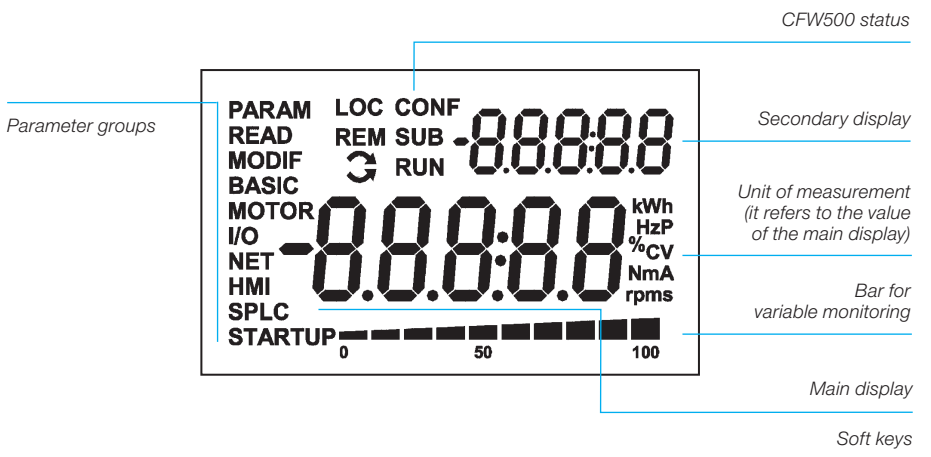

## Friendly Programming

- Oriented start-up: programming step by step
- Soft keys: fast access to the parameters
- Parameter group: it directs to the parameters of interest

## Remote HMI

Solution for panel door or machine console.



CFW500-HMIR IP54



RS485  
Included in all plug-in modules

CFW500-CCHMIRXM  
X = up to 10 m

## Energy Efficiency

In the industry, the electric motors are responsible for nearly 70% of all the electric energy consumption. By using VSD, it is possible to reduce consumption up to 40%.

Besides being efficient in the control of electric motors, they reduce machine wear, save raw material, improve process quality and increase productivity.

On WEG website, it is possible to calculate how much energy can be saved by using the CFW500 VSD.

Ensure energy efficiency for your equipment and machines. Save money and contribute to the conservation of the environment.



# SuperDrive G2

Software application for programming, command and monitoring of WEG VSD.

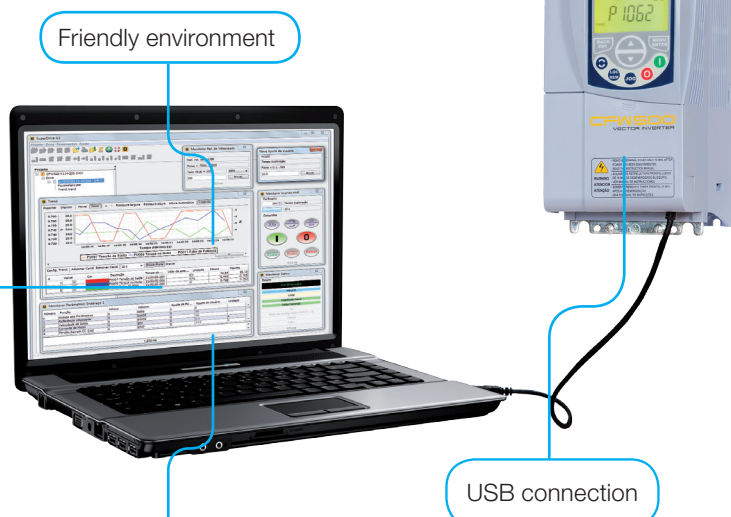

## Trace Function

- On-line graphic monitoring of parameters/variables
- Possibility to export an image with the respective graph according to the selected period

Free on [www.weg.net](http://www.weg.net)

## Edition and Monitoring of Parameters in List/Table

Parameter set storage in a computer file format.

Number	Function	Minimum	Maximum	Factory Setting	User Setting	Unit
0	Access to Parameters	0	9999	0	0	
1	Speed Reference	0	65535	0	30	
2	Motor Speed	0	65535	0	30	
3	Motor Current	0	200	0	0.1	A
4	DC Link Voltage (Ud)	0	2000	0	311	V
5	Motor Frequency	0	500	0	2.5	Hz
6	VFD Status	0	7	0: Ready	1: Run	
7	Motor Voltage	0	2000	0	23	V
9	Motor Torque	-1000	1000	0	-5.2	%
11	Motor Current	-1	1	0	0.75	
12	DI8 to DI1 Status	00000000b	11111111b	00000000b	00000000b	
13	DO5 to DO1 Status	00000000b	01111111b	00000000b	00000001b	
14	AO1 Value	0	100	0	4.3	%
15	AO2 Value	0	100	0	1.4	%
16	FO % Value	0	100	0	0	%
17	FO Hz Value	0	20000	0	0	Hz
18	AI1 Value	-100	100	0	0	%
19	AI2 Value	-100	100	0	0	%
20	AI3 Value	-100	100	0	-100	%
21	FI % Value	-100	100	0	0	%
22	FI Hz Value	0	20000	0	0	Hz
23	Main SW Version	0	655.35	0	1.14	
24	Sec. SW Version	0	655.35	1.11	1	
27	Plug-In Mod. Config.	00000000b	00001001b	00000000b	00000001b	
29	Power HW Config.	00000000b	00111111b	00000000b	00000011b	
30	Heatsink Temperature	-20	150	0	25	C
37	Motor Overload Lxt	0	100	0	0	%
40	PID Process Variable	0	3000	0	0	
41	PID Setpoint Value	0	3000	0	0	
47	CONF State	0	999	0	0	
48	Present Alarm	0	999	0	0	
49	Present Fault	0	999	0	0	
50	Last Fault	0	999	0	0	
51	Current At Last Fault	0	200	0	0	A
52	DC Link At Last Fault	0	2000	0	0	V
53	Speed At Last Fault	0	500	0	0	Hz

- Transfer of parameters from the PC to the CF500 and vice versa
- Off-line edition of the parameters stored on the PC

## Status Monitoring

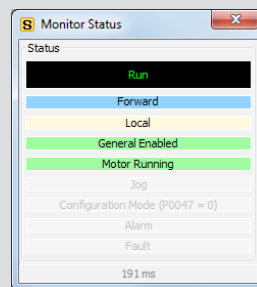

## Operation with HMI

On-line parameter edition

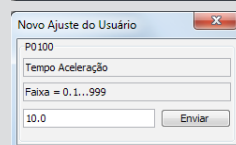
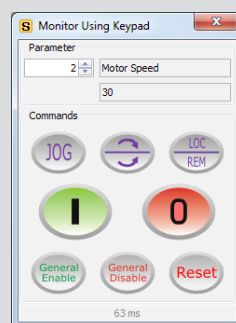



# SoftPLC - Built-in on the Standard Product

It adds the functionalities of a PLC to the CFW500, allowing the creation of applications. The WLP software and the SoftPLC functionality are a smart and simple way to make your CFW500, motor and application work together.

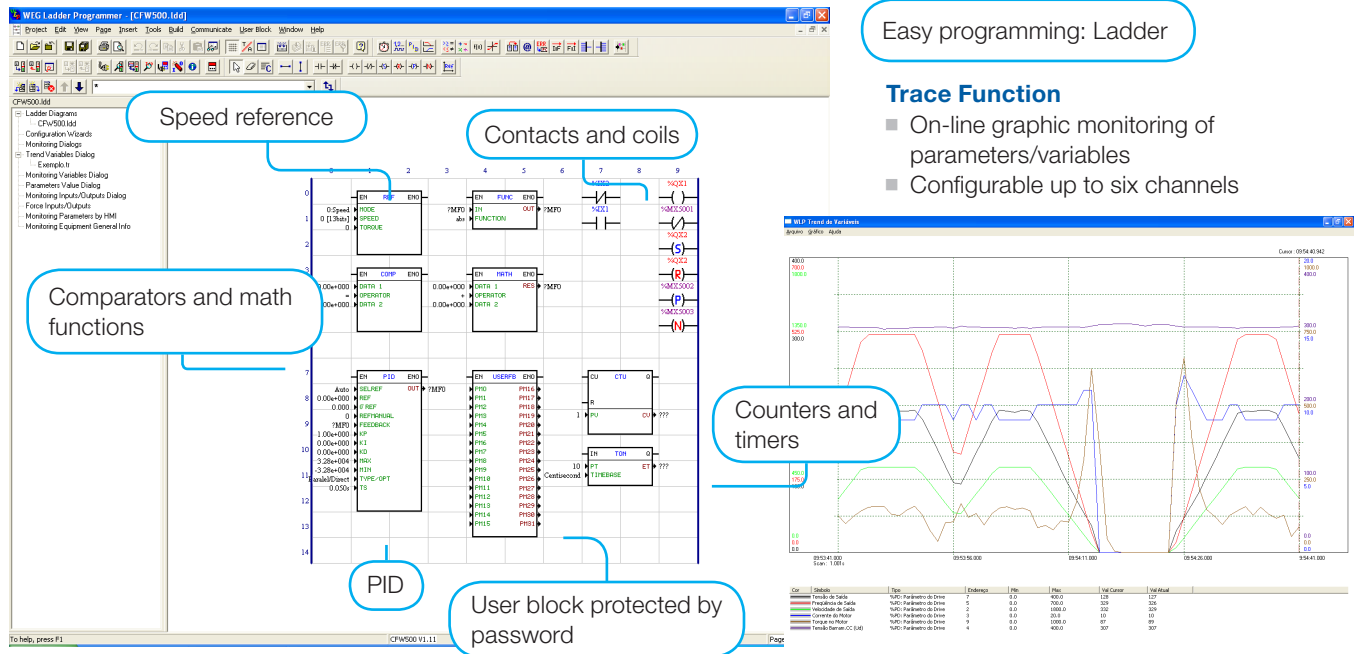

**Easy programming: Ladder**

**Trace Function**

- On-line graphic monitoring of parameters/variables
- Configurable up to six channels

**Counters and timers**

**PID**

**User block protected by password**

## On-line Monitoring Parameters/Variables List

Symbol	Type	Address	Value	
Motor Current	%PD: Drive Parameter	3	9	Insert
Motor Frequency	%PD: Drive Parameter	5	511	Edit
Motor Voltage	%PD: Drive Parameter	7	188	Write
DC Link Voltage (Ud)	%PD: Drive Parameter	4	305	Delete
Analog Input AI1	%IW: Analog Input	1	32193	Up
Digital Input DI1	%IX: Digital Input	1	0	Down

## Parameter Edition

It allows to change the parameters values.

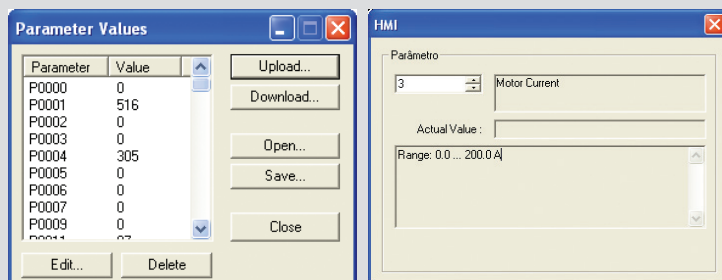

## Enable/Disable I/Os

It simplifies and speeds up the validation of the application

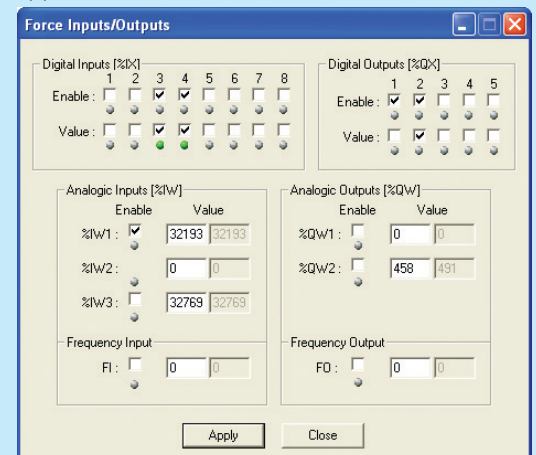

## I/Os Monitoring



## Coding

The CFW500 code identifies its constructive characteristics, maximum current, voltage range and optionals. Using the smart code, it is possible to select the CFW500 necessary for your application in a simple and fast way.

Product and series	Model identification				Braking <sup>1</sup>	Degree of protection <sup>1</sup>	Conducted emission level <sup>1</sup>	Hardware version	Software version
	Frame size	Rated current	No. of phases	Rated voltage					
CFW500	A	03P6	T	4	NB	20	C3	H00	---
CFW500	Check table below								
	NB = without dynamic braking DB = with dynamic braking								
	20 = IP20 N1 = NEMA1 enclosure								
	Blank = with no RFI filter C2 = According to category 2 of IEC 61800-3 standard, with internal RFI filter C3 = According to category 3 of IEC 61800-3 standard, with internal RFI filter								
	H00 = without plug-in module								
	Blank = standard Sx = special software								

(1) To know what models have this options in the standard product the table below shall be checked.

Frame sizes	Output Current	Input	Power supply voltage	Braking	Degree of protection	Conducted emission level <sup>(2)</sup>
A	01P6 = 1.6 A	S = single-phase power supply	2 = 200... 240 V	NB	20 or N1	Blank or C2
	02P6 = 2.6 A					
	04P3 = 4.3 A					Blank or C3
	07P0 = 7.0 A					
A	01P6 = 1.6 A	B = single-phase or three-phase power supply		NB		Blank
	02P6 = 2.6 A					
	04P3 = 4.3 A					
B	07P3 = 7.3 A			DB		
	10P0 = 10 A					
A	07P0 = 7.0 A			T = three-phase power supply		
	09P6 = 9.6 A					
B	16P0 = 16 A	DB				
C	24P0 = 24 A	DB				
A	01P0 = 1.0 A	T = three-phase power supply	4 = 380...480 V		NB	Blank or C2
	01P6 = 1.6 A					
	02P6 = 2.6 A			Blank or C3		
	04P3 = 4.3 A					
B	06P1 = 6.1 A			DB	Blank or C2	
	02P7 = 2.7 A					
	04P3 = 4.3 A					
	06P5 = 6.5 A					
C	10P0 = 10 A			DB	Blank or C3	
	14P0 = 14.0 A					
	16P0 = 16.0 A					

(2) RFI filter

Categories:

Category C1: inverters with voltages below 1,000 V, for use in the First Environment.

Category C2: inverters with voltages below 1,000 V, with plugs or mobile installation, when used in the "First Environment", must be installed and started-up by a qualified professional.

Category C3: inverters with voltages below 1,000 V, developed for use in the Second Environment and not designed for use in the "First Environment".

Environments:

First Environment: environments that include household installations, such as buildings directly connected, without intermediate transformer, to a low-voltage power supply grid, which supplies buildings used for domestic purposes.

Second Environment: includes all the buildings other than those directly connected to a low-voltage power supply grid, which supplies buildings used for domestic purposes.

For the RFI filters of external installations, refer to the CFW500 user manual.

## Drive Ratings

The correct way to select a VSD is matching its output current to the motor rated current. However, the tables below present the expected motor power for each VSD model.

Use the motor power ratings below only as a guidance. Motor rated currents may vary with speed and manufacturer. IEC motor powers are based on WEG 4-pole motors; NEMA motor powers are based on NEC table 430-150.

### Motor Voltages Between 220 V and 230 V

Power supply	Model	Rated current A	IEC	IEC	NEMA	
			50 Hz 220 V 230 V	60 Hz 220 V	60 Hz 230 V	
200-240 V	10	CFW500 A 01P6 S2	1.6	0.25	0.25	1
		CFW500 A 02P6 S2	2.6	0.55	0.5	1
		CFW500 A 04P3 S2	4.3	1.1	1	1.5
	1/30	CFW500 A 07P0 S2	7	1.5	2	2
		CFW500 A 01P6 B2	1.6	0.25	0.25	1
		CFW500 A 02P6 B2	2.6	0.55	0.5	1
		CFW500 A 04P3 B2	4.3	1.1	1	1.5
		CFW500 B 07P3 B2	7.3	1.5	2	2
		CFW500 B 10P0 B2	10	2.2	3	3
	30	CFW500 A 07P0 T2	7	1.5	2	2
		CFW500 A 09P6 T2	9.6	2.2	3	3
		CFW500 B 16P0 T2	16	4	5	5
	CFW500 C 24P0 T2	24	5.5	7.5	7.5	

### Motor Voltages Between 380 V and 480 V

Power supply	Model	Rated current A	IEC		NEMA	
			50 Hz 380 V 415 V	60 Hz 440 V 460 V	60 Hz 460 V	
380-480 V	30	CFW500 A 01P0 T4	1	0.25	0.5	1
		CFW500 A 01P6 T4	1.6	0.75	0.75	1
		CFW500 A 02P6 T4	2.6	1.1	1.5	2
		CFW500 A 04P3 T4	4.3	1.5	3	3
		CFW500 A 06P1 T4	6.1	3	4	3
		CFW500 B 02P6 T4	2.6	1.1	1.5	2
		CFW500 B 04P3 T4	4.3	1.5	3	3
		CFW500 B 06P5 T4	6.5	3	4	5
		CFW500 B 10P0 T4	10	4	7.5	7.5
		CFW500 C 14P0 T4	14	7.5	10	10
		CFW500 C 16P0 T4	16	7.5	12.5	10

## Dimensions and Weights

### IP20

Frame size	H mm	W mm	D mm	Weight Kg
A	189.1	75.2	149.5	0.8
B	199.1	100.2	160.1	1.2
C	210	135.2	165.1	2



### NEMA1

Frame size	H mm	W mm	D mm	Weight Kg
A	223	75.2	149.5	1.05
B	243.3	100.2	160.1	1.49
C	254.8	135.2	165.1	2.35



## Accessories and Optionals

The CFW500 VSD was developed to meet the hardware configurations required by a wide range of applications. The table below presents the available options:

Option	Type <sup>(1)</sup>	Description	Optional item code <sup>(2)</sup>	Accessory model	Available
RFI filter	Optional	Used to reduce the disturbance conducted from the CFW500 to the power supply, in the high frequency band (>150 kHz), according to standards 61800-3 and EN 55011.	C2 o C3	-	Installed at the factory
Braking IGBT	Optional	Used in high-inertia applications for the fast stop of the motor by means of an external braking resistance. Resistance not included. For the calculation of the braking resistance, refer to the CFW500 user manual.	DB	-	Installed at the factory
Degree of protection NEMA1	Optional or accessory	Used for the CFW500 VSD to have degree of protection NEMA1 and/or when metallic conduits are used for the cables.	N1	CFW500-KN1A (frame size A) CFW500-KN1B (frame size B) CFW500-KN1C (frame size C)	Installed at the factory or at the application
Cable shield kit	Accessory	Used to shield the power and control cables. Important: for the version with RFI filter, this filter comes with the product.	-	CFW500-KPCSA (frame size A) CFW500-KPCSB (frame size B) CFW500-KPCSC (frame size C)	Installed at the application
I/O expansion modules (plug-in) <sup>(3)</sup>	Accessory	Used to configure the I/O points according to the needs of the application/machine.	-	CFW500-IOS CFW500-IOD CFW500-IOAD CFW500-IOR	Installed at the application
Communication module (plug-in) <sup>(3)</sup>	Accessory	Used for the communication of the CFW500 with the main networks of the market (Fieldbus).	-	CFW500-CUSB (USB) CFW500-CCAN (CANopen /DeviceNet) CFW500-CRS232 CFW500-CRS485 CFW500-CPDP (Profibus-DP)	Installed at the application
Flash memory module (plug-in) <sup>(3)</sup>	Accessory	Used to download the programming of a CFW500 to others without having to power them up.	-	CFW500-MMF	Installed at the application
Remote HMI	Accessory	Used to transfer the operation to the panel door or machine console. Maximum distance of 10m. Degree of protection IP54.	-	CFW500-HMIR	Installed at the application
Cables for remote HMI	Accessory	Used to interconnect the CFW500 to the remote HMI (CFW500-HMIR).	-	CFW500-CCHMIRXM, where cables with lengths (X) of 1, 2, 3, 5, 7,5 and 10 meters	Installed at the application

(1) Optional = hardware resources added to the CFW500 in the manufacturing process  
Accessory = hardware resource requested as a separated item.

(2) Request the product according to the code available on page 10.

### Plug-in Modules Specification <sup>(3)</sup>

Plug-in module	Functions										
	Inputs		Outputs			USB Port	Fieldbus networks			Power supply	
	Digital	Analog	Analog	Digital relay	Digital transistor		RS232	RS485	Profibus-DP	10 V	24 V
CFW500-IOS	4	1	1	1	1	-	-	1	-	1	1
CFW500-IOD	8	1	1	1	4	-	-	1	-	1	1
CFW500-IOAD	6	3	2	1	3	-	-	1	-	1	1
CFW500-IOR	4	1	1	4	1	-	-	1	-	1	1
CFW500-CUSB	4	1	1	1	1	1	-	1	-	1	1
CFW500-CCAN	2	1	1	1	1	-	1	1	-	1	1
CFW500-CRS232	2	1	1	1	1	-	1	1	-	-	1
CFW500-CRS485	4	2	1	2	1	-	-	2	-	1	1
CFW500-CPDP	2	1	1	1	1	-	-	1	1	-	1

(3) All models of plug-in modules have at least one RS485 port. The CFW500-CRS485 plug-in module has two RS485 ports. The CFW500 allows installing one plug-in module per unit.

### Step by Step



# Block Diagram

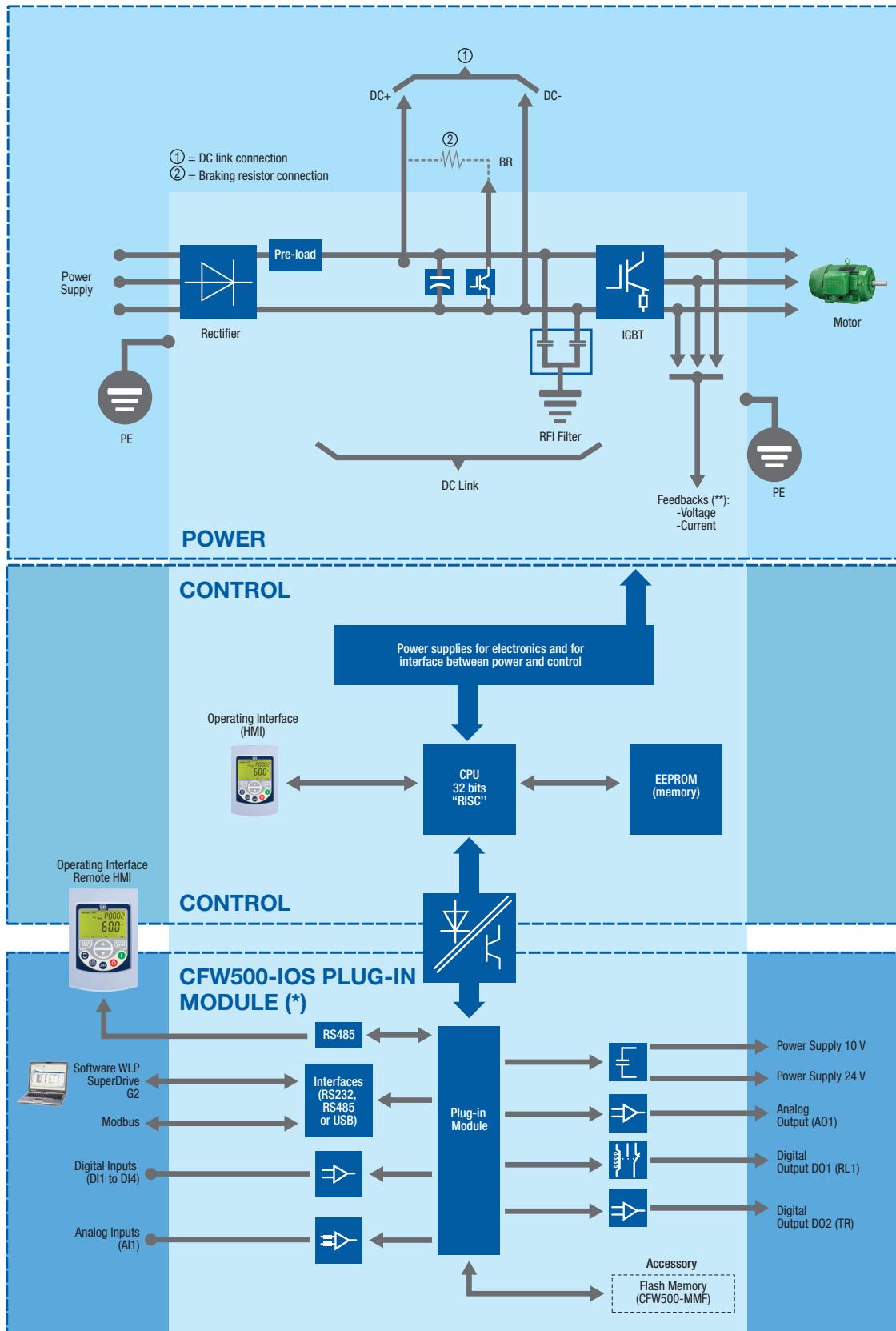

(\*) The number of inputs and outputs (analog and digital), as well as other resources, may vary according to the used plug-in module. For further information, refer to the CFW500 user manual.

(\*\*) Not available for frame size A.

## Technical Data

Power supply	Voltage and power range	1-phase, 200-240 V ac ( +10%-15%) 0.25 to 2 HP (0.25 to 1.5 kW)
		1-phase/3-phase, 200-240 V ac ( +10%-15%) 0.25 to 3 HP (0.25 to 2.2 kW)
3-phase, 200-240 V ac ( +10%-15%) 2 to 7.5 HP (1.5 to 5.5 kW)		
3-phase, 380-480 V ac ( +10%-15%) 0.5 to 12.5 HP (0.25 to 7.5 kW)		
	Supply frequency	50/60 Hz (48 Hz to 62 Hz)
Motor connection	Voltage	3-phase, 0-100% of supplied voltage
	Output frequency	0 a 500 Hz
	Displacement power factor	>0.97
	Overload capacity	1.5 x I <sub>n</sub> (drive) for 1 minute every 6 minutes
	Switching frequency	Default 5 kHz (selectable 2.5 to 15 kHz)
	Acceleration time	0.1 to 999s
	Desacceleration time	0.1 to 999s
Environment	Temperature	40 °C - NEMA1
		40 °C - IP20 side by side and/or with RFI filter
		50 °C - IP20 without RFI filter
		2% of current derating for each °C above the specific operating temperature, limited to an increase of 10 °C
	Humidity	5 % to 90 % non-condensing
Altitude	Up to 1000 m - rated conditions	
	1000 m to 4000 m - 1 % of current derating for each 100 m above 1000 m of altitude	
Degree of protection	IP20 or NEMA1 (with kit NEMA1)	
Performance	V/f control	Speed regulation: 1 % of the rated speed (with slip compensation) Speed variation range: 1:20
	Vector control (VWV)	Speed regulation: 1 % of the rated speed Speed variation range: 1:30
Braking methods	DC Current applied to motor dynamic braking	Available as standard for frame sizes B and C. For frame size A "DB" models has to be used. An extra resistor must be fitted in for dynamic braking capability
Safety	Protection	Overcurrent/phase-phase short circuit in the output
		Overcurrent/phase-ground short circuit in the output
		Under/overvoltage
		Overtemperature in the heatsink
		Overload in the motor
		Overload in the power module (IGBTs)
		External alarm / fault
Setting error		
Communication	Modbus-RTU	All plug-in modules for RS485 and CFW500-CRS232 for RS232
	Profibus-DP	Plug-in module CFW500-CPDP
	DeviceNet	Plug-in module CFW500-CCAN
	CANopen	Plug-in module CFW500-CCAN
Chokes (external as accessory)	AC input chokes	For reducing THD
	AC output chokes	For longer motor cables

## Technical Data - Standards

Safety standards	UL 508C	Power conversion equipment.
	UL 840	Insulation coordination including clearances and creepage distances for electrical equipment.
	EN61800-5-1	Safety requirements electrical, thermal and energy.
	EN 50178	Electronic equipment for use in power installations.
	EN 60204-1	Safety of machinery. Electrical equipment of machines. Part 1: General requirements. <i>Note: For the machine to comply with this standard, the manufacturer of the machine is responsible for installing an emergency stop device and equipment to disconnect the input power supply.</i>
	EN 60146 (IEC 146)	Semiconductor converters.
	EN 61800-2	Adjustable speed electrical power drive systems - Part 2: General requirements - Rating specifications for low voltage adjustable frequency AC power drive systems.
Electromagnetic Compatibility (EMC) Standards	EN 61800-3	Adjustable speed electrical power drive systems - Part 3: EMC product standard including specific test methods.
	EN 55011	Limits and methods of measurement of radio disturbance characteristics of industrial, scientific and medical (ISM) radio-frequency equipment.
	CISPR 11	Industrial, scientific and medical (ISM) radio-frequency equipment - Electromagnetic disturbance characteristics - Limits and methods of measurement.
	EN 61000-4-2	Electromagnetic compatibility (EMC) - Part 4: Testing and measurement techniques - Section 2: Electrostatic discharge immunity test.
	EN 61000-4-3	Electromagnetic compatibility (EMC) - Part 4: Testing and measurement techniques - Section 3: Radiated, radio-frequency, electromagnetic field immunity test.
	EN 61000-4-4	Electromagnetic compatibility (EMC) - Part 4: Testing and measurement techniques - Section 4: Electrical fast transient/burst immunity test.
	EN 61000-4-5	Electromagnetic compatibility (EMC) - Part 4: Testing and measurement techniques - Section 5: Surge immunity test.
	EN 61000-4-6	Electromagnetic compatibility (EMC) - Part 4: Testing and measurement techniques - Section 6: Immunity to conducted disturbances, induced by radio-frequency fields.
Mechanical construction standards	EN 60529	Degrees of protection provided by enclosures (IP code).
	UL 50	Enclosures for electrical equipment.



# WEG Worldwide Operations

## ARGENTINA

WEG EQUIPAMIENTOS  
ELECTRICOS  
San Francisco - Cordoba  
Phone: +54 3564 421 484  
[info-ar@weg.net](mailto:info-ar@weg.net)  
[www.weg.net/ar](http://www.weg.net/ar)

WEG PINTURAS - Pulverlux  
Buenos Aires  
Phone: +54 11 4299 8000  
[tintas@weg.net](mailto:tintas@weg.net)

## AUSTRALIA

WEG AUSTRALIA  
Victoria  
Phone: +61 3 9765 4600  
[info-au@weg.net](mailto:info-au@weg.net)  
[www.weg.net/au](http://www.weg.net/au)

## AUSTRIA

WATT DRIVE - WEG Group  
Markt Piesting - Viena  
Phone: +43 2633 404 0  
[watt@wattdrive.com](mailto:watt@wattdrive.com)  
[www.wattdrive.com](http://www.wattdrive.com)

## BELGIUM

WEG BENELUX  
Nivelles - Belgium  
Phone: +32 67 88 84 20  
[info-be@weg.net](mailto:info-be@weg.net)  
[www.weg.net/be](http://www.weg.net/be)

## BRAZIL

WEG EQUIPAMENTOS ELÉTRICOS  
Jaraguá do Sul - Santa Catarina  
Phone: +55 47 3276-4002  
[info-br@weg.net](mailto:info-br@weg.net)  
[www.weg.net/br](http://www.weg.net/br)

## CHILE

WEG CHILE  
Santiago  
Phone: +56 2 784 8900  
[info-cl@weg.net](mailto:info-cl@weg.net)  
[www.weg.net/cl](http://www.weg.net/cl)

## CHINA

WEG NANTONG  
Nantong - Jiangsu  
Phone: +86 0513 8598 9333  
[info-cn@weg.net](mailto:info-cn@weg.net)  
[www.weg.net/cn](http://www.weg.net/cn)

## COLOMBIA

WEG COLOMBIA  
Bogotá  
Phone: +57 1 416 0166  
[info-co@weg.net](mailto:info-co@weg.net)  
[www.weg.net/co](http://www.weg.net/co)

## FRANCE

WEG FRANCE  
Saint Quentin Fallavier - Lyon  
Phone: +33 4 74 99 11 35  
[info-fr@weg.net](mailto:info-fr@weg.net)  
[www.weg.net/fr](http://www.weg.net/fr)

## GERMANY

WEG GERMANY  
Kerpen - North Rhine Westphalia  
Phone: +49 2237 9291 0  
[info-de@weg.net](mailto:info-de@weg.net)  
[www.weg.net/de](http://www.weg.net/de)

## GHANA

ZEST ELECTRIC GHANA  
WEG Group  
Accra  
Phone: +233 30 27 664 90  
[info@zestghana.com.gh](mailto:info@zestghana.com.gh)  
[www.zestghana.com.gh](http://www.zestghana.com.gh)

## INDIA

WEG ELECTRIC INDIA  
Bangalore - Karnataka  
Phone: +91 80 4128 2007  
[info-in@weg.net](mailto:info-in@weg.net)  
[www.weg.net/in](http://www.weg.net/in)

WEG INDUSTRIES INDIA  
Hosur - Tamil Nadu  
Phone: +91 4344 301 501  
[info-in@weg.net](mailto:info-in@weg.net)  
[www.weg.net/in](http://www.weg.net/in)

## ITALY

WEG ITALIA  
Cinisello Balsamo - Milano  
Phone: +39 02 6129 3535  
[info-it@weg.net](mailto:info-it@weg.net)  
[www.weg.net/it](http://www.weg.net/it)

## JAPAN

WEG ELECTRIC MOTORS  
JAPAN  
Yokohama City - Kanagawa  
Phone: +81 45 550 3030  
[info-jp@weg.net](mailto:info-jp@weg.net)  
[www.weg.net/jp](http://www.weg.net/jp)

## MEXICO

WEG MEXICO  
Huehuetoca  
Phone: +52 55 5321 4231  
[info-mx@weg.net](mailto:info-mx@weg.net)  
[www.weg.net/mx](http://www.weg.net/mx)

VOLTRAN - WEG Group  
Tizayuca - Hidalgo  
Phone: +52 77 5350 9354  
[www.voltran.com.mx](http://www.voltran.com.mx)

## NETHERLANDS

WEG NETHERLANDS  
Oldenzaal - Overijssel  
Phone: +31 541 571 080  
[info-nl@weg.net](mailto:info-nl@weg.net)  
[www.weg.net/nl](http://www.weg.net/nl)

## PERU

WEG PERU  
Lima  
Phone: +51 1 472 3204  
[info-pe@weg.net](mailto:info-pe@weg.net)  
[www.weg.net/pe](http://www.weg.net/pe)

## PORTUGAL

WEG EURO  
Maia - Porto  
Phone: +351 22 9477705  
[info-pt@weg.net](mailto:info-pt@weg.net)  
[www.weg.net/pt](http://www.weg.net/pt)

## RUSSIA and CIS

WEG ELECTRIC CIS  
Saint Petersburg  
Phone: +7 812 363 2172  
[info-ru@weg.net](mailto:info-ru@weg.net)  
[www.weg.net/ru](http://www.weg.net/ru)

## SOUTH AFRICA

ZEST ELECTRIC MOTORS  
WEG Group  
Johannesburg  
Phone: +27 11 723 6000  
[info@zest.co.za](mailto:info@zest.co.za)  
[www.zest.co.za](http://www.zest.co.za)

## SPAIN

WEG IBERIA  
Madrid  
Phone: +34 91 655 30 08  
[info-es@weg.net](mailto:info-es@weg.net)  
[www.weg.net/es](http://www.weg.net/es)

## SINGAPORE

WEG SINGAPORE  
Singapore  
Phone: +65 68589081  
[info-sg@weg.net](mailto:info-sg@weg.net)  
[www.weg.net/sg](http://www.weg.net/sg)

## SCANDINAVIA

WEG SCANDINAVIA  
Kungsbacka - Sweden  
Phone: +46 300 73 400  
[info-se@weg.net](mailto:info-se@weg.net)  
[www.weg.net/se](http://www.weg.net/se)

## UK

WEG ELECTRIC MOTORS U.K.  
Redditch - Worcestershire  
Phone: +44 1527 513 800  
[info-uk@weg.net](mailto:info-uk@weg.net)  
[www.weg.net/uk](http://www.weg.net/uk)

## UNITED ARAB EMIRATES

WEG MIDDLE EAST  
Dubai  
Phone: +971 4 813 0800  
[info-ae@weg.net](mailto:info-ae@weg.net)  
[www.weg.net/ae](http://www.weg.net/ae)

## USA

WEG ELECTRIC  
Duluth - Georgia  
Phone: +1 678 249 2000  
[info-us@weg.net](mailto:info-us@weg.net)  
[www.weg.net/us](http://www.weg.net/us)

ELECTRIC MACHINERY  
WEG Group  
Minneapolis - Minnesota  
Phone: +1 612 378 8000  
[www.electricmachinery.com](http://www.electricmachinery.com)

## VENEZUELA

WEG INDUSTRIAS VENEZUELA  
Valencia - Carabobo  
Phone: +58 241 821 0582  
[info-ve@weg.net](mailto:info-ve@weg.net)  
[www.weg.net/ve](http://www.weg.net/ve)

For those countries where there is not a WEG own operation, find our local distributor at [www.weg.net](http://www.weg.net).



Grupo WEG - Automation Business Unit  
Jaraguá do Sul - SC - Brazil  
Phone: +55 47 3276 4000  
[automacao@weg.net](mailto:automacao@weg.net)  
[www.weg.net](http://www.weg.net)

