

SLM Series Motors and SLG Series Integrated Gearmotors

Brushless servo motor and gearmotor technology from Exlar provides the highest torque-to-size ratio available in motion control today. Small size, outstanding performance specifications, quality and customization capabilities offer you the solution you need for your motion control application.

Very High Torque Density

Exlar's T-LAM technology produces an efficient and powerful motor in a very small package.

- **60 mm SLM060** offers continuous torque up to 15 lbf-in and base speed of 5000 rpm.
- **90 mm SLM090** offers continuous torque up to 56 lbf-in and base speed of 4000 rpm.
- **115 mm SLM115** offers continuous torque up to 176 lbf-in and base speed of 3000 rpm.
- **142 mm SLM142** offers continuous torque up to 237 lbf-in and base speed of 2400 rpm.
- **180 mm SLM180** offers continuous torque up to 612 lbf-in and base speed of 2400 rpm.

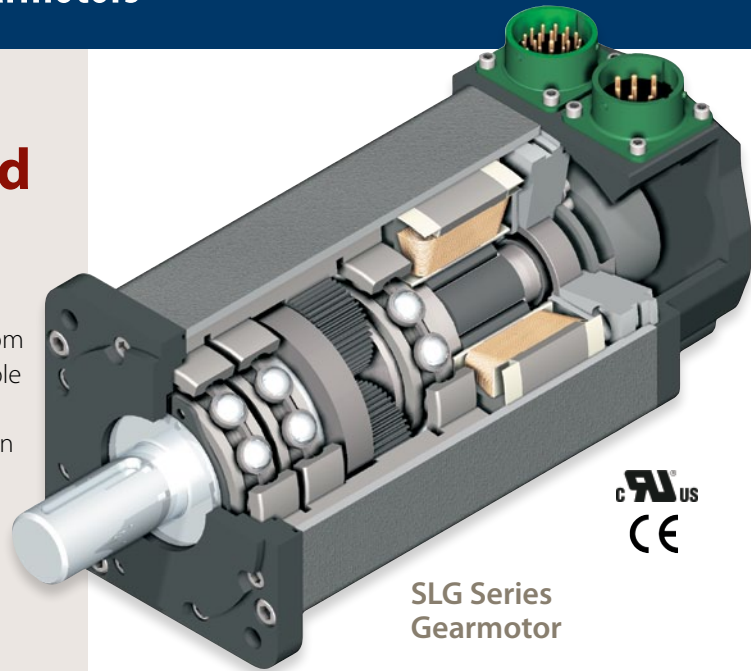

SLG Series Gearmotor



Standard Features	
SLM Motor	SLM Motor Standard Features
	UL recognized component IP65S sealing
	MS connectors embedded leads, or embedded leads with cable plugs
	Feedback configurations for nearly all servo amplifiers
	Anodized housings
	Class 180H insulation system
SLG Gearmotor	All features of SLM motor shown above plus...
	High side load bearing design
	Integrated armature and sungear
	Higher stiffness than bolt-on gearhead and motor
	10 arc minute standard backlash, single stage; 13 arc minute standard backlash, dual stage
	Single and double reduction ratios: 4:1, 5:1, 10:1, 16:1, 20:1, 25:1, 40:1, 50:1, and 100:1

Unique T-LAM™ Stator Design Advantage

This innovative design offers several advantages over traditional motor winding for a more efficient and powerful motor.

Built for durability, T-LAM segmented lamination stator technology consists of individual segments, each containing individual phase wiring for maximum motor performance. The robust insulation, high coercive strength magnets, and complete thermal potting all provide a more robust motor design – a design yielding a 35 to 70% torque increase in the same package size! T-LAM motor designs have Class 180-H insulation systems and UL recognition.

Customization to Suit Your Requirements

Exlar Corporation has capabilities allowing custom motors to be manufactured to meet your OEM requirements. Whatever your special requirements are... custom shafts, custom mountings, custom stators, custom housing materials... please contact Exlar or your local sales representative to discuss your needs.

Typical Applications

SLM Series Motors and SLG Series Gearmotors are perfectly suited for applications in any industry.

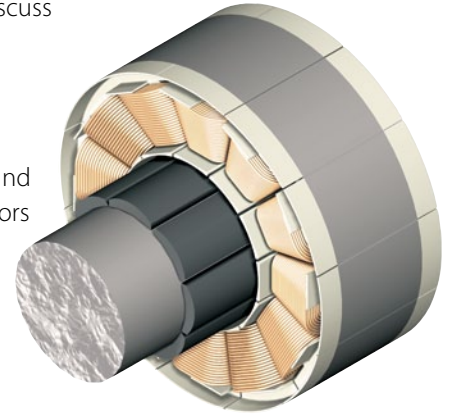

EXLAR SLM & SLG Series Motors applications include:

Semiconductor

Plastics Machinery

Tensioning

Web Feed

Fluid Handling

Stage Positioning

Medical Applications

Winding Machines

Glass Manufacturing

Food Processing

Conveyor Drives

Automotive Assembly

Parts Handling

Screw Drives

Labeling

Machine Tools

Simulation Robotics

Packaging

SLM/SLG Series

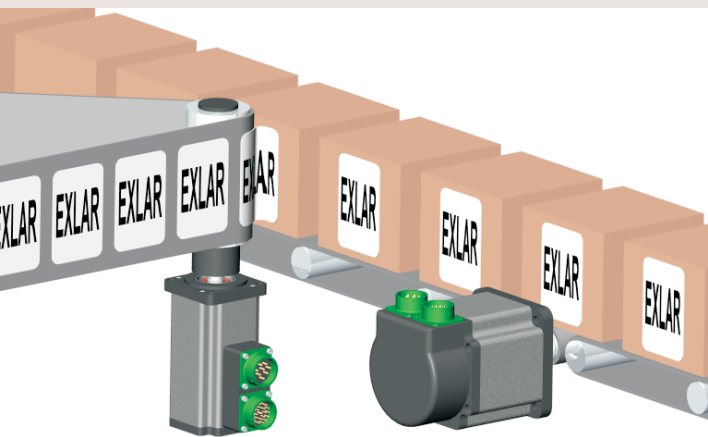

Exlar's brushless motors are the highest performance with very compact size. This makes them perfect for high-speed labeling and demanding conveyor drive applications.

Exlar's closed-loop, servo-controlled rotary actuators are ideal for operating quarter-turn, full-turn, or multi-turn valves or shaft driven dampers.

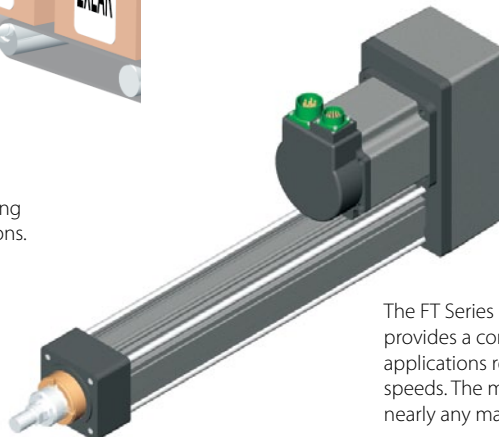
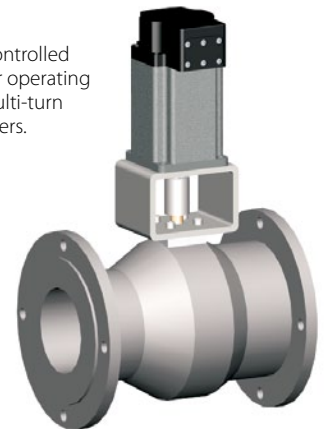

The FT Series combined with SLM/G Series motors provides a complete Exlar actuator solution for applications requiring heavy load capacity and high speeds. The motor can be configured to operate with nearly any manufacturer's servo amplifier.

SLM/SLG Speed/Torque Curves

These speed vs. torque curves represent approximate continuous torque ratings at indicated rpms. Different types of servo amplifiers will offer varying motor torque.

----- Peak Torque
 ——— Continuous Torque

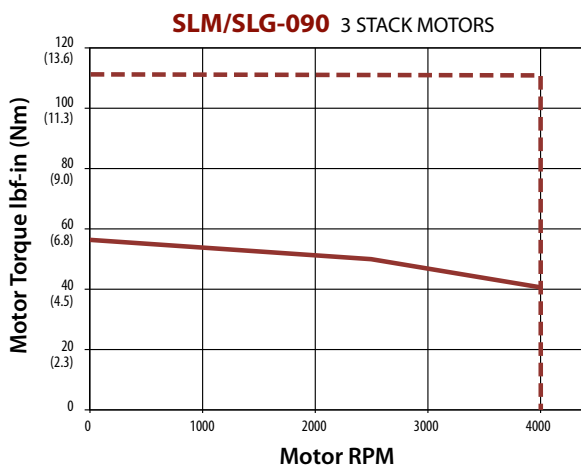
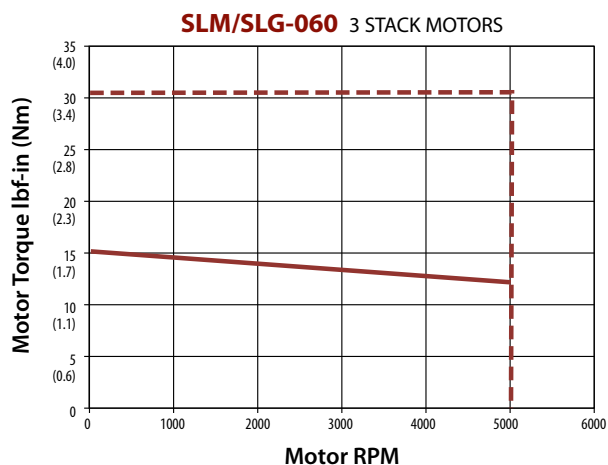
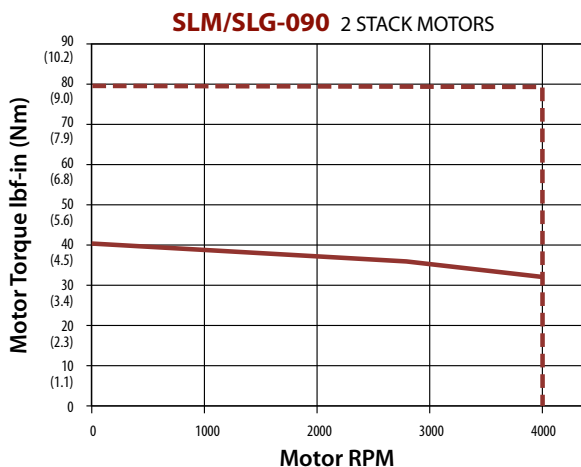
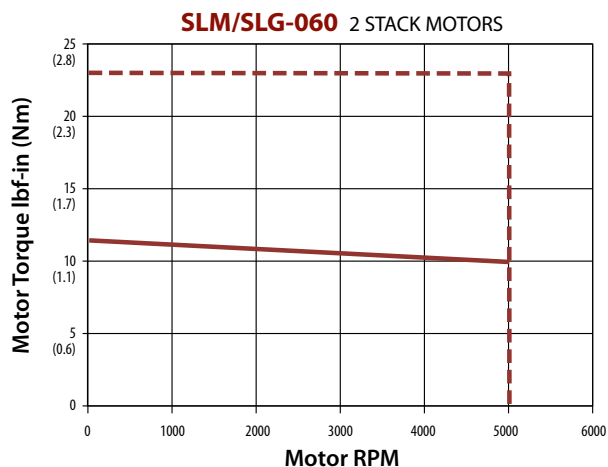
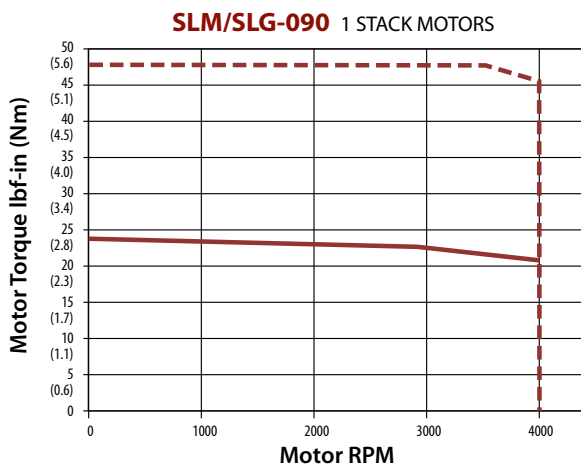
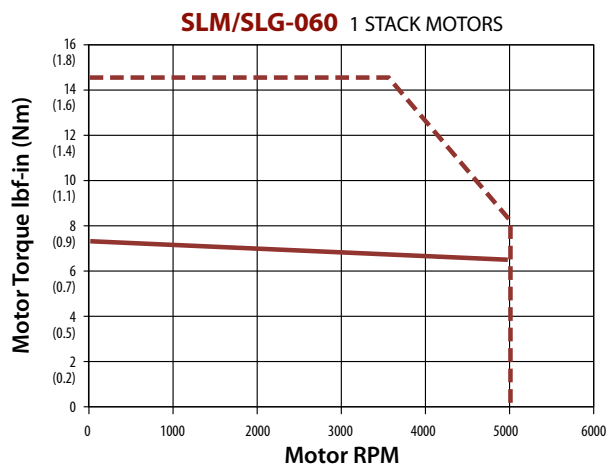

Test data derived using NEMA recommended aluminum heatsink 10" x 10" x 1/4" on SLM/SLG060 and 10" x 10" x 3/8" on SLM/SLG090

SLM/SLG Speed/Torque Curves

- - - Peak Torque
— Continuous Torque

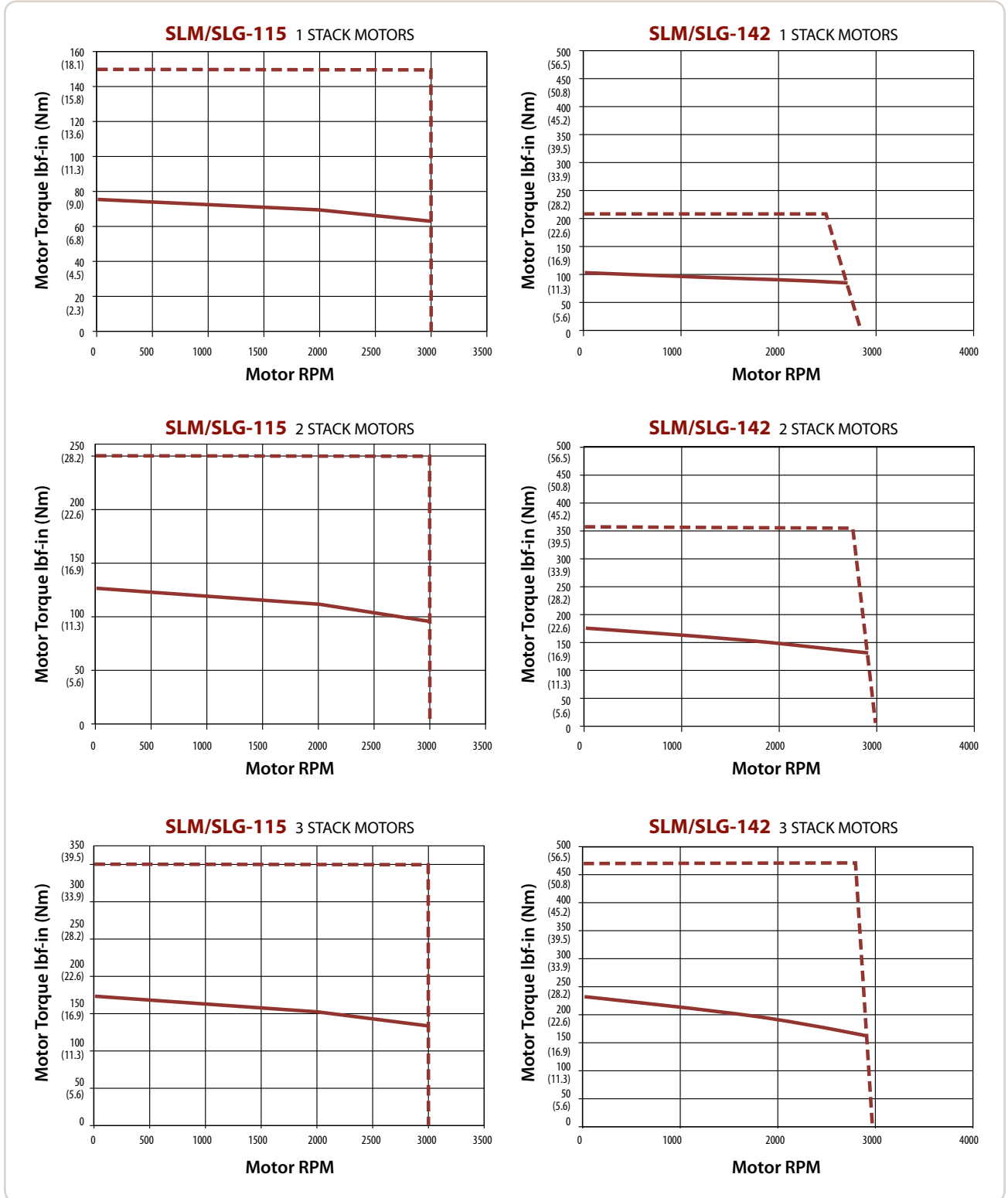

Test data derived using NEMA recommended aluminum heatsink 12" x 12" x 1/2" on SLM/SLG115 and 12" x 12" x 1/2" on SLM/SLG142

SLM/SLG Series

SLM Speed/Torque Curves

These speed vs. torque curves represent approximate continuous torque ratings at indicated rpms. Different types of servo amplifiers will offer varying motor torque.

- - - - - Peak Torque
- Continuous Torque

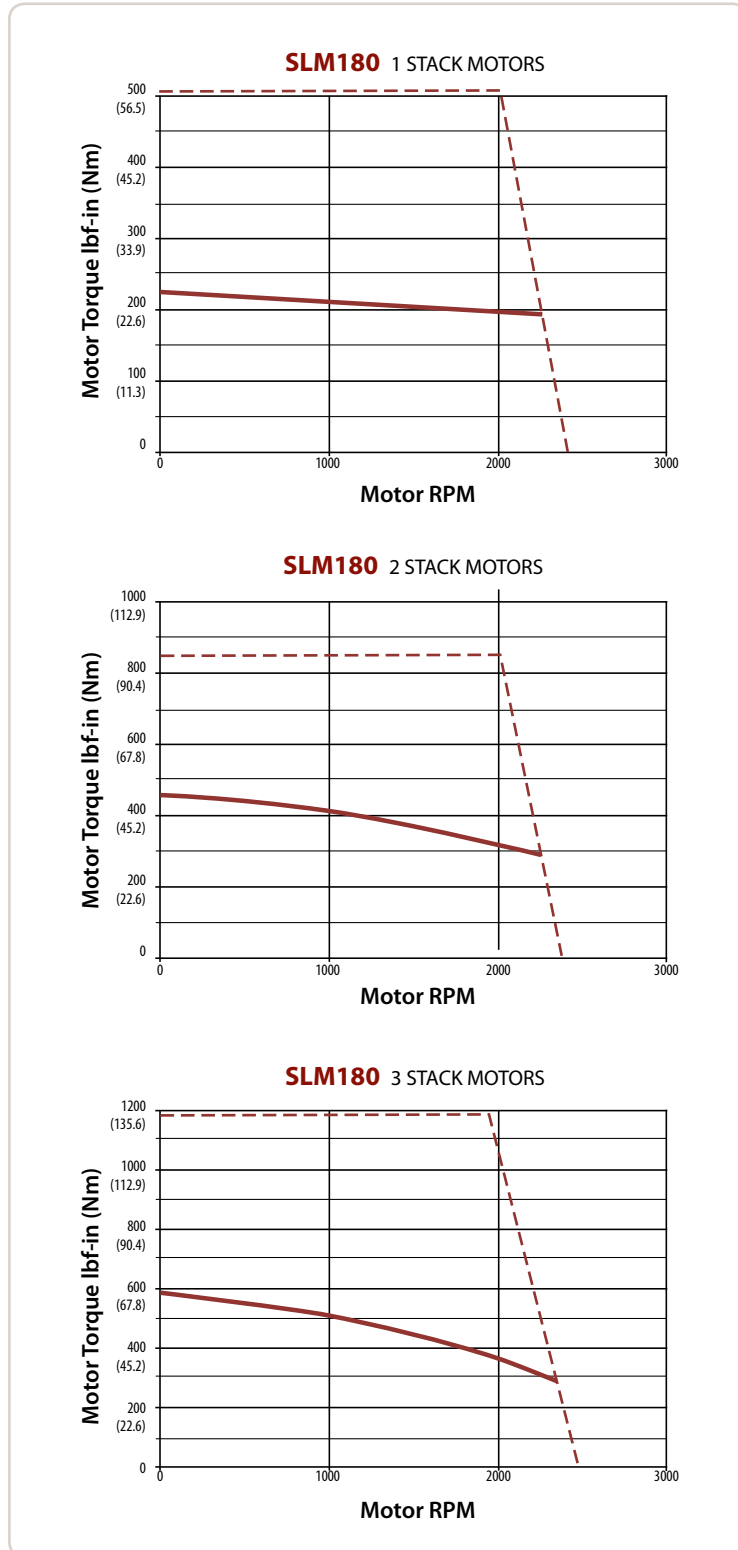

Test data derived using NEMA recommended aluminum heatsink 16" x 16" x 1"

SLM/SLG060 Electrical/Mechanical Specifications

SLM/G060 Stator Data		1 Stack Motor				2 Stack Motor				3 Stack Motor			
Sinusoidal Commutation Data		118	138	158	168	218	238	258	268	318	338	358	368
Continuous Motor Torque	lbf-in (Nm)	7.6 (0.86)	7.3 (0.83)	7.0 (0.79)	7.0 (0.79)	11.9 (1.34)	11.5 (1.30)	11.0 (1.25)	11.3 (1.28)	15.0 (1.70)	15.3 (1.73)	14.6 (1.65)	14.9 (1.69)
Peak Motor Torque	lbf-in (Nm)	15.2 (1.72)	14.7 (1.66)	14.0 (1.58)	14.0 (1.58)	23.8 (2.69)	23.0 (2.60)	22.1 (2.49)	22.6 (2.55)	30.0 (3.39)	30.6 (3.46)	29.2 (3.30)	29.9 (3.38)
Torque Constant (Kt) (+/- 10% @ 25°C)	lbf-in/A (Nm/A)	2.5 (0.28)	5.2 (0.6)	7.5 (0.9)	9.5 (1.1)	2.5 (0.3)	5.2 (0.6)	8.6 (1.0)	10.1 (1.1)	2.5 (0.3)	5.3 (0.6)	8.8 (1.0)	10.1 (1.1)
Continuous Current Rating	A	3.4	1.6	1.0	0.8	5.4	2.5	1.4	1.2	6.6	3.2	1.9	1.6
Peak Current Rating	A	6.9	3.1	2.0	1.6	10.8	4.9	2.9	2.5	13.2	6.5	3.7	3.3
O-PK SINUSOIDAL COMMUTATION DATA													
Continuous Motor Torque	lbf-in (Nm)	7.6 (0.86)	7.3 (0.83)	7.0 (0.79)	7.0 (0.79)	11.9 (1.34)	11.5 (1.30)	11.0 (1.25)	11.3 (1.28)	15.0 (1.70)	15.3 (1.73)	14.6 (1.65)	14.9 (1.69)
Peak Motor Torque	lbf-in (Nm)	15.2 (1.72)	14.7 (1.66)	14.0 (1.58)	14.0 (1.58)	23.8 (2.69)	23.0 (2.60)	22.1 (2.49)	22.6 (2.55)	30.0 (3.39)	30.6 (3.46)	29.2 (3.30)	29.9 (3.38)
Torque Constant (Kt) (+/- 10% @ 25°C)	lbf-in/A (Nm/A)	1.7 (0.20)	3.7 (0.4)	5.3 (0.6)	6.7 (0.8)	1.7 (0.2)	3.7 (0.4)	6.1 (0.7)	7.2 (0.8)	1.8 (0.2)	3.7 (0.4)	6.2 (0.7)	7.2 (0.8)
Continuous Current Rating	A	4.9	2.2	1.5	1.2	7.6	3.5	2.0	1.8	9.4	4.6	2.6	2.3
Peak Current Rating	A	9.7	4.5	2.9	2.3	15.2	7.0	4.1	3.5	18.7	9.2	5.3	4.7
MOTOR DATA													
Voltage Constant (Ke) (+/- 10% @ 25°C)	Vrms/Krpm Vpk/Krpm	16.9 23.9	35.5 50.2	51.5 72.8	64.8 91.7	16.9 23.9	35.5 50.2	58.6 82.9	69.3 98.0	17.3 24.5	36.0 50.9	59.9 84.8	69.3 98.0
Pole Configuration		8	8	8	8	8	8	8	8	8	8	8	8
Resistance (L-L)(+/- 5% @ 25°C)	Ohms	2.6	12.52	28.82	45.79	1.11	5.26	15.51	20.69	0.76	3.14	9.57	12.22
Inductance (L-L)(+/- 15%)	mH	4.6	21.4	47.9	68.3	2.5	10.2	28.3	39.5	1.7	7.4	18.5	27.4
SLM Armature Inertia (+/- 5%)	lbf-in-sec ² (Kg-cm ²)	0.000237 (0.268)				0.000413 (0.466)				0.000589 (0.665)			
Brake Inertia	lbf-in-sec ² (Kg-cm ²)	0.00012 (0.135)				0.000120 (0.135)				0.000120 (0.135)			
Brake Current @ 24VDC	A	.33				.33				.33			
Brake Holding Torque	lbf-in (Nm)	19 (2.2)				19 (2.2)				19 (2.2)			
Brake Engage/Disengage Time	ms	14/28				14/28				14/28			
Mechanical Time Constant (tm)	ms	2.20	2.38	2.60	2.61	1.62	1.74	1.89	1.80	1.50	1.45	1.59	1.52
Electrical Time Constant (te)	ms	1.76	1.71	1.66	1.49	2.24	1.95	1.82	1.91	2.27	2.36	1.93	2.24
Friction Torque	lbf-in (Nm)	0.27 (0.031)				0.34 (0.038)				0.38 (0.043)			
Voltage Rating	Vrms	115	230	400	460	115	230	400	460	115	230	400	460
Speed @ Bus Voltage	rpm	5000											
Insulation Class		180 (H)											
Insulation System Volt Rating	Vrms	460											
Environmental Rating		IP65S											

For amplifiers using peak sinusoidal ratings, multiply RMS sinusoidal Kt by .707 and current by 1.414.

SLG060 Gearmotor Data

	1 Stack Motor			2 Stack Motor			3 Stack Motor		
SLG Armature Inertia* lbf-in-sec ² (Kg-cm ²)	0.000226 (0.255)			0.000401 (0.453)			0.000576 (0.651)		
GEARING REFLECTED INERTIA	SINGLE REDUCTION						DOUBLE REDUCTION		
	Gear Stages	lbf-in-sec ²	(Kg-cm ²)	Gear Stages	lbf-in-sec ²	(Kg-cm ²)			
	4:1	0.0000132	(0.0149)	16:1	0.0000121	(0.0137)			
	5:1	0.0000087	(0.00984)	20:1, 25:1	0.0000080	(0.00906)			
	10:1	0.0000023	(0.00261)	40:1, 50:1, 100:1	0.0000021	(0.00242)			
Backlash at 1% rated torque:	10 Arc minutes Efficiency: Single reduction 91%						13 Arc minutes Double Reduction: 86%		

* Add armature inertia to gearing inertia for total SLG system inertia
Test data derived using NEMA recommended aluminum heatsink 10" x 10" x 1/4"

SLM/SLG090 Electrical/Mechanical Specifications

SLM/G090 Stator Data		1 Stack Motor				2 Stack Motor				3 Stack Motor		
Sinusoidal Commutation Data		118	138	158	168	218	238	258	268	338	358	368
Continuous Motor Torque	lbf-in (Nm)	23.8 (2.68)	24.0 (2.71)	23.7 (2.67)	24.7 (2.79)	39.6 (4.47)	40.0 (4.52)	39.5 (4.46)	39.9 (4.51)	55.7 (6.30)	55.4 (6.26)	55.7 (6.30)
Peak Motor Torque	lbf-in (Nm)	47.5 (5.37)	48.0 (5.42)	47.3 (5.35)	49.4 (5.58)	79.1 (8.94)	80.0 (9.04)	79.0 (8.93)	79.9 (9.02)	111.5 (12.59)	110.9 (12.52)	111.5 (12.59)
Torque Constant (Kt) (+/- 10% @ 25°C)	lbf-in/A (Nm/A)	3.2 (0.37)	6.6 (0.7)	11.6 (1.3)	13.2 (1.5)	3.2 (0.4)	6.6 (0.7)	11.6 (1.3)	13.2 (1.5)	6.6 (0.7)	11.6 (1.3)	13.1 (1.5)
Continuous Current Rating	A	8.2	4.0	2.3	2.1	13.6	6.8	3.8	3.4	9.5	5.3	4.8
Peak Current Rating	A	16.4	8.1	4.6	4.2	27.3	13.5	7.6	6.7	19.0	10.7	9.5
O-PK SINUSOIDAL COMMUTATION DATA												
Continuous Motor Torque	lbf-in (Nm)	23.8 (2.68)	24.0 (2.71)	23.7 (2.67)	24.7 (2.79)	39.6 (4.47)	40.0 (4.52)	39.5 (4.46)	39.9 (4.51)	55.7 (6.30)	55.4 (6.26)	55.7 (6.30)
Peak Motor Torque	lbf-in (Nm)	47.5 (5.37)	48.0 (5.42)	47.3 (5.35)	49.4 (5.58)	79.1 (8.94)	80.0 (9.04)	79.0 (8.93)	79.9 (9.02)	111.5 (12.59)	110.9 (12.52)	111.5 (12.59)
Torque Constant (Kt) (+/- 10% @ 25°C)	lbf-in/A (Nm/A)	2.3 (0.26)	4.7 (0.5)	8.2 (0.9)	9.4 (1.1)	2.3 (0.3)	4.7 (0.5)	8.2 (0.9)	9.4 (1.1)	4.6 (0.5)	8.2 (0.9)	9.3 (1.0)
Continuous Current Rating	A	11.6	5.7	3.2	2.9	19.3	9.5	5.4	4.8	13.4	7.5	6.7
Peak Current Rating	A	23.2	11.4	6.5	5.9	38.6	19.1	10.8	9.5	26.9	15.1	13.4
MOTOR DATA												
Voltage Constant (Ke) (+/- 10% @ 25°C)	Vrms/Krpm (Vpk/Krpm)	22.1	45.2	78.9	90.4	22.1	45.2	78.9	90.4	44.7	79.4	89.5
Pole Configuration		8	8	8	8	8	8	8	8	8	8	8
Resistance (L-L)(+/- 5% @ 25°C)	Ohms	0.75	3.06	9.57	11.55	0.30	1.21	3.78	4.86	0.69	2.19	2.75
Inductance (L-L)(+/- 15%)	mH	6.1	25.6	78.0	88.6	2.9	10.5	37.2	43.1	6.6	24.7	31.4
SLM Armature Inertia (+/- 5%)	lbf-in-sec ² (Kg-cm ²)	0.00054 (0.609)				0.00097 (1.09)				0.00140 (1.58)		
Brake Inertia	lbf-in-sec ² (Kg-cm ²)	0.00096 (1.08)				0.00096 (1.08)				0.00096 (1.08)		
Brake Current @ 24 VDC	A	.67				.67				.67		
Brake Holding Torque	lbf-in (Nm)	97 (11)				97 (11)				97 (11)		
Brake Engage/Disengage Time	ms	20/29				20/29				20/29		
Mechanical Time Constant (tm)	ms	0.83	0.82	0.84	0.77	0.59	0.58	0.59	0.58	0.48	0.49	0.48
Electrical Time Constant (te)	ms	8.21	7.31	8.14	7.67	9.88	8.66	9.85	8.88	9.57	11.30	11.43
Friction Torque	lbf-in (Nm)	0.68 (0.077)				0.85 (0.095)				1.06 (0.119)		
Voltage Rating	Vrms	115	230	400	460	115	230	400	460	230	400	460
Speed @ Bus Voltage	rpm	4000										
Insulation Class		180 (H)										
Insulation System Volt Rating	Vrms	460										
Environmental Rating		IP65S										

For amplifiers using peak sinusoidal ratings, multiply RMS sinusoidal Kt by .707 and current by 1.414.

SLG090 Gearmotor Data

	1 Stack Motor			2 Stack Motor			3 Stack Motor		
SLG Armature Inertia* lbf-in-sec ² (Kg-cm ²)	0.00114 (1.29)			0.00157 (1.77)			0.00200 (2.26)		
GEARING REFLECTED INERTIA	SINGLE REDUCTION						DOUBLE REDUCTION		
	Gear Stages	lbf-in-sec ²	(Kg-cm ²)	Gear Stages	lbf-in-sec ²	(Kg-cm ²)			
	4:1	0.000154	(0.174)	16:1	0.000115	(0.130)			
	5:1	0.000100	(0.113)	20:1, 25:1	0.0000756	(0.0854)			
	10:1	0.0000265	(0.0300)	40:1, 50:1, 100:1	0.0000203	(0.0230)			
Backlash at 1% rated torque:	10 Arc minutes						13 Arc minutes		
	Efficiency: Single reduction 91%						Double Reduction: 86%		

* Add armature inertia to gearing inertia for total SLG system inertia
Test data derived using NEMA recommended aluminum heatsink 10" x 10" x 3/8"

SLM/SLG115 Electrical/Mechanical Specifications

SLM/SLG115 Stator Data		1 Stack Motor				2 Stack Motor			3 Stack Motor		
Sinusoidal Commutation Data		118	138	158	168	238	258	268	338	358	368
Continuous Motor Torque	lbf-in (Nm)	74.1 (8.37)	74.1 (8.37)	74.3 (8.39)	74.1 (8.37)	123.6 (13.96)	121.4 (13.72)	123.8 (13.96)	172.3 (19.46)	168.9 (19.09)	176.9 (19.98)
Peak Motor Torque	lbf-in (Nm)	148.2 (16.74)	148.2 (16.74)	148.6 (16.79)	148.1 (16.74)	247.2 (27.93)	242.8 (27.43)	247.2 (27.93)	344.5 (38.93)	337.8 (38.17)	353.7 (39.96)
Torque Constant (Kt) (+/- 10% @ 25°C)	lbf-in/A (Nm/A)	4.3 (0.49)	8.7 (1.0)	15.7 (1.8)	17.3 (2.0)	8.7 (1.0)	15.8 (1.8)	17.3 (2.0)	8.5 (1.0)	15.8 (1.8)	17.5 (2.0)
Continuous Current Rating	A	19.1	9.5	5.3	4.8	15.9	8.6	8.0	22.7	11.9	11.3
Peak Current Rating	A	38.2	19.1	10.6	9.5	31.8	17.1	15.9	45.4	23.8	22.5
O-PK SINUSOIDAL COMMUTATION DATA											
Continuous Motor Torque	lbf-in (Nm)	74.1 (8.37)	74.1 (8.37)	74.3 (8.39)	74.1 (8.37)	123.6 (13.96)	121.4 (13.72)	123.6 (13.96)	172.3 (19.46)	168.9 (19.09)	176.9 (19.98)
Peak Motor Torque	lbf-in (Nm)	148.2 (16.74)	148.2 (16.74)	148.6 (16.79)	148.1 (16.74)	247.2 (27.93)	242.8 (27.43)	247.2 (27.93)	344.5 (38.93)	337.8 (38.17)	353.7 (39.96)
Torque Constant (Kt) (+/- 10% @ 25°C)	lbf-in/A (Nm/A)	3.1 (0.35)	6.1 (0.7)	11.1 (1.3)	12.3 (1.4)	6.1 (0.7)	11.2 (1.3)	12.3 (1.4)	6.0 (0.7)	11.2 (1.3)	12.4 (1.4)
Continuous Current Rating	A	27.0	13.5	7.5	6.7	22.5	12.1	11.3	32.1	16.9	15.9
Peak Current Rating	A	54.0	27.0	15.0	13.5	45.0	24.2	22.5	64.2	33.7	31.9
MOTOR DATA											
Voltage Constant (Ke) (+/- 10% @ 25°C)	Vrms/Krpm (Vpk/Krpm)	29.6	59.2	106.9	118.5	59.2	108.2	118.5	58.0	108.2	119.8
Pole Configuration		8	8	8	8	8	8	8	8	8	8
Resistance (L-L) (+/- 5% @ 25°C)	Ohms	0.20	0.80	2.60	3.21	0.34	1.17	1.35	0.20	0.72	0.81
Inductance (L-L) (+/- 15%)	mH	3.3	13.0	42.4	52.1	6.3	21.1	25.3	4.0	13.1	17.1
SLM Armature Inertia (+/- 5%)	lbf-in-sec ² (Kg-cm ²)	0.00344 (3.89)				0.00623 (7.036)			0.00901 (10.181)		
Brake Inertia	lbf-in-sec ² (Kg-cm ²)	0.00327 (3.70)				0.00327 (3.70)			0.00327 (3.70)		
Brake Current @ 24VDC	A	.75				.75			.75		
Brake Holding Torque	lbf-in (Nm)	195 (22)				195 (22)			195 (22)		
Brake Engage/Disengage Time	ms	25/50				25/50			25/50		
Mechanical Time Constant (tm)	ms	0.80	0.80	0.79	0.80	0.61	0.63	0.61	0.54	0.56	0.51
Electrical Time Constant (te)	ms	16.26	16.26	16.34	16.25	18.72	18.06	18.72	20.08	18.14	21.16
Friction Torque	lbf-in (Nm)	1.43 (0.16)				1.81 (0.204)			2.32 (0.262)		
Voltage Rating	Vrms	115	230	400	460	230	400	460	230	400	460
Speed @ Bus Voltage	rpm	3000									
Insulation Class		180 (H)									
Insulation System Volt Rating	Vrms	460									
Environmental Rating		IP65S									

For amplifiers using peak sinusoidal ratings, multiply RMS sinusoidal Kt by .707 and current by 1.414.

SLG115 Gearmotor Data

	1 Stack Motor			2 Stack Motor			3 Stack Motor			
SLG Armature Inertia* lbf-in-sec ² (Kg-cm ²)	0.00538 (6.08)			0.00816 (9.22)			0.0109 (12.31)			
GEARING REFLECTED INERTIA	SINGLE REDUCTION						DOUBLE REDUCTION			
	Gear Stages	lbf-in-sec ²		(Kg-cm ²)		Gear Stages	lbf-in-sec ²		(Kg-cm ²)	
	4:1	0.000635		(0.717)		16:1	0.000513		(0.580)	
	5:1	0.000428		(0.484)		20:1, 25:1	0.000350		(0.396)	
	10:1	0.000111		(0.125)		40:1, 50:1, 100:1	0.0000911		(0.103)	
Backlash at 1% rated torque:	10 Arc minutes						13 Arc minutes			
	Efficiency: Single reduction 91%						Double Reduction: 86%			

* Add armature inertia to gearing inertia for total SLG system inertia
Test data derived using NEMA recommended aluminum heatsink 12" x 12" x 1/2"

SLM142 Electrical/Mechanical Specifications

SLM142 Stator Data		1 Stack Motor				2 Stack Motor			3 Stack Motor	
Sinusoidal Commutation Data		118	138	158	168	238	258	268	358	368
Continuous Motor Torque	lbf-in (Nm)	108.5 (12.25)	107.2 (12.12)	104.8 (11.84)	109.4 (12.36)	179.9 (20.32)	178.8 (20.20)	177.8 (20.09)	237.2 (26.80)	238.3 (26.93)
Peak Motor Torque	lbf-in (Nm)	216.9 (24.51)	214.5 (24.23)	209.5 (23.67)	218.8 (24.72)	359.8 (40.65)	357.6 (40.40)	355.7 (40.19)	474.4 (53.60)	476.7 (53.85)
Torque Constant (Kt) (+/- 10% @ 25°C)	lbf-in/A (Nm/A)	5.9 (0.67)	11.8 (1.3)	20.2 (2.3)	23.6 (2.7)	11.8 (1.3)	20.2 (2.3)	23.6 (2.7)	20.2 (2.3)	24.0 (2.7)
Continuous Current Rating	A	20.5	10.2	5.8	5.2	17.0	9.9	8.4	13.1	11.1
Peak Current Rating	A	41.1	20.3	11.6	10.4	34.1	19.8	16.8	26.2	22.2
O-PK SINUSOIDAL COMMUTATION DATA										
Continuous Motor Torque	lbf-in (Nm)	108.5 (12.25)	107.2 (12.12)	104.8 (11.84)	109.4 (12.36)	179.9 (20.32)	178.8 (20.20)	177.8 (20.09)	237.2 (26.80)	238.3 (26.93)
Peak Motor Torque	lbf-in (Nm)	216.9 (24.51)	214.5 (24.23)	209.5 (23.67)	218.8 (24.72)	359.8 (40.65)	357.6 (40.40)	355.7 (40.19)	474.4 (53.60)	476.7 (53.85)
Torque Constant (Kt) (+/- 10% @ 25°C)	lbf-in/A (Nm/A)	4.2 (0.47)	8.3 (0.9)	14.3 (1.6)	16.7 (1.9)	8.3 (0.9)	14.3 (1.6)	16.7 (1.9)	14.3 (1.6)	17.0 (1.9)
Continuous Current Rating	A	29.1	14.4	8.2	7.3	24.1	14.0	11.9	18.5	15.7
Peak Current Rating	A	58.1	28.7	16.4	14.7	48.2	27.9	23.8	37.1	31.4
MOTOR DATA										
Voltage Constant (Ke) (+/- 10% @ 25°C)	Vrms/Krpm (Vpk/Krpm)	40.3	80.6	138.1	161.1	80.6	138.1	161.1	138.1	164.0
Pole Configuration		8	8	8	8	8	8	8	8	8
Resistance (L-L)(+/- 5% @ 25°C)	Ohms	0.21	0.87	2.68	3.34	0.339	1.01	1.39	0.61	0.858
Inductance (L-L)(+/- 15%)	mH	5.4	21.7	63.9	78.3	10.4	27.6	41.5	20.0	28.2
Armature Inertia (+/- 5%)	lb-in-sec ² (Kg-cm ²)	0.00927 (10.47)				0.01537 (17.363)			0.02146 (24.249)	
Brake Inertia	lb-in-sec ² (Kg-cm ²)	0.008408 (9.5)				0.008408 (9.5)			0.008408 (9.5)	
Brake Current @ 24 VDC	A	1.0				1.0			1.0	
Brake Holding Torque	lbf-in (Nm)	354 (39.99)				354 (39.99)			354 (39.99)	
Brake Engage/Disengage Time	ms	25/73				25/73			25/73	
Mechanical Time Constant (tm)	ms	1.23	1.26	1.32	1.21	0.81	0.82	0.83	0.70	0.69
Electrical Time Constant (te)	ms	25.59	25.02	23.88	23.43	30.58	27.30	29.89	32.60	32.90
Friction Torque	lbf-in (Nm)	2.07 (0.234)				2.65 (0.299)			3.32 (0.375)	
Bus Voltage	Vrms	115	230	400	460	230	400	460	400	460
Speed @ Bus Voltage	RPM	2400								
Insulation Class		180 (H)								
Insulation System Volt Rating	Vrms	460								
Environmental Rating		IP65S								

For amplifiers using peak sinusoidal ratings, multiply RMS sinusoidal Kt by .707 and current by 1.414.
 Gearmotor not available on 142 frame motor.
 Test data derived using NEMA recommended aluminum heatsink 12" x 12" x 1/2"

SLM180 Electrical/Mechanical Specifications

SLM180 Motor Stator		1 Stack Motor			2 Stack Motor			3 Stack Motor	
RMS Sinusoidal Commutation Data		138	158	168	238	258	268	358	368
Continuous Motor Torque	lbf-in (Nm)	254.2 (28.72)	249.9 (28.23)	261.9 (29.59)	424.8 (47.99)	423.0 (47.79)	427.5 (48.30)	595.6 (67.29)	611.6 (69.10)
Peak Motor Torque	lbf-in (Nm)	508.4 (57.44)	499.8 (56.47)	523.8 (59.18)	849.6 (95.99)	846.0 (95.59)	855.1 (96.61)	1,191.2 (134.58)	1,223.2 (138.19)
Torque Constant (Kt) (+/- 10% @ 25°C)	lbf-in/A (Nm/A)	12.6 (1.4)	21.8 (2.5)	25.2 (2.8)	12.6 (1.4)	21.8 (2.5)	25.2 (2.8)	21.4 (2.4)	25.2 (2.8)
Continuous Current Rating (IG)	A	22.6	12.8	11.6	37.7	21.7	19.0	31.1	27.2
Peak Current Rating	A	45.2	25.6	23.3	75.5	43.4	38.0	62.2	54.3
O-PK SINUSOIDAL COMMUTATION DATA									
Continuous Motor Torque	lbf-in (Nm)	254.2 (28.72)	249.9 (28.23)	261.9 (29.59)	424.8 (47.99)	423.0 (47.79)	427.5 (48.30)	595.6 (67.29)	611.6 (69.10)
Peak Motor Torque	lbf-in (Nm)	508.4 (57.44)	499.8 (56.47)	523.8 (59.18)	849.6 (95.99)	846.0 (95.59)	855.1 (96.61)	1,191.2 (134.58)	1,223.2 (138.19)
Torque Constant (Kt) (+/- 10% @ 25°C)	lbf-in/A (Nm/A)	8.9 (1.0)	15.4 (1.7)	17.8 (2.0)	8.9 (1.0)	15.4 (1.7)	17.8 (2.0)	15.1 (1.7)	17.8 (2.0)
Continuous Current Rating	A	31.9	18.1	16.4	53.4	30.7	26.8	44.0	38.4
Peak Current Rating	A	63.9	36.2	32.9	106.7	61.3	53.7	88.0	76.8
MOTOR STATOR DATA									
Voltage Constant (Ke) (+/- 10% @ 25°C)	Vrms/Krpm (Vpk/Krpm)	85.9	148.9	171.8	85.9	148.9	171.8	146.1	171.8
Pole Configuration		8	8	8	8	8	8	8	8
Resistance (L-L) (+/- 5% @ 25°C)	Ohms	0.325	1.010	1.224	0.134	0.407	0.530	0.233	0.306
Inductance (L-L) (+/- 15%)	mH	8.3	24.8	29.4	3.9	11.8	15.8	7.5	10.3
Armature Inertia (+/- 5%)	lb-in-sec ² (Kg-cm ²)	0.05051 (57.071)			0.08599 (97.159)			0.12147 (137.246)	
Brake Inertia	lb-in-sec ² (Kg-cm ²)	0.02815 (31.8)							
Brake Current @ 24VDC	A	1.45							
Brake Holding Torque	lbf-in (Nm)	708 (80)							
Brake Engage/Disengage Time	ms	53/97							
Mechanical Time Constant (tm)	ms	2.25	2.33	2.12	1.58	1.59	1.56	1.34	1.27
Electrical Time Constant (te)	ms	25.44	24.58	24.03	29.38	29.14	29.76	32.07	33.81
Friction Torque	lbf-in (Nm)	5.07 (0.573)			7.80 (0.881)			11.52 (1.302)	
Bus Voltage	Vrms	230	400	460	230	400	460	400	460
Speed @ Bus Voltage	RPM	2400							
Insulation Class		180 (H)							
Insulation System Volt Rating	Vrms	460							
Thermal Switch, Case Temp	deg C	100							
Environmental Rating		IP655							

For amplifiers using peak sinusoidal ratings, multiply RMS sinusoidal Kt by .707 and current by 1.414.
 All temperature ratings ambient.
 Gearmotor not available on 180 frame.
 Test data derived using NEMA recommended aluminum heatsink 16" x 16" x 1"

SLG Series Gearmotor General Performance Specifications

Two torque ratings for the SLG Series Gearmotors are given in the table below. The left hand columns give the maximum (peak) allowable output torque for the indicated ratios of each size SLG Series Gearmotor. This is **NOT** the rated output torque of the motor multiplied by the ratio of the reducer.

It is possible to select a configuration of the motor selection and gear ratio such that the rated motor torque,

multiplied by the gear ratio exceeds these ratings. It is the responsibility of the user to ensure that the settings of the system, including the amplifier, do not allow these values to be exceeded.

The right hand columns give the output torque at the indicated speed which will result in 10,000 hour (L10). The setup of the system, including the amplifier, will determine the actual output torque and speed.

Output Torque Ratings–Mechanical

Model	Ratio	Maximum Allowable Output Torque – Set by User	Output Torque @ Speed for 10,000 Hour Life – lbf-in (Nm)		
			1000 RPM	3000 RPM	5000 RPM
SLG060	4:1	603 (68.1)	144 (16.2)	104 (11.7)	88 (9.9)
	5:1	522 (58.9)	170 (19.2)	125 (14.1)	105 (11.9)
	10:1	327 (36.9)	200 (22.6)	140 (15.8)	120 (13.6)
	16:1	603 (68.1)	224 (25.3)	160 (18.1)	136 (15.4)
	20:1	603 (68.1)	240 (27.1)	170 (19.2)	146 (16.5)
	25:1	522 (58.9)	275 (31.1)	200 (22.6)	180 (20.3)
	40:1	603 (68.1)	288 (32.5)	208 (23.5)	180 (20.3)
	50:1	522 (58.9)	340 (38.4)	245 (27.7)	210 (23.7)
	100:1	327 (36.9)	320 (36.1)	280 (31.6)	240 (27.1)
			1000 RPM	2500 RPM	4000 RPM
SLG090	4:1	2078 (234.8)	600 (67.8)	456 (51.5)	396 (44.7)
	5:1	1798 (203.1)	775 (87.6)	590 (66.7)	510 (57.6)
	10:1	1126 (127.2)	890 (100.6)	680 (76.8)	590 (66.7)
	16:1	2078 (234.8)	912 (103.4)	688 (77.7)	592 (66.9)
	20:1	2078 (234.8)	980 (110.7)	740 (83.6)	640 (72.3)
	25:1	1798 (203.1)	1250 (141.2)	950 (107.3)	825 (93.2)
	40:1	2078 (234.8)	1200 (135.6)	920 (103.9)	800 (90.4)
	50:1	1798 (203.1)	1550 (169.4)	1200 (135.6)	1000 (112.9)
	100:1	1126 (127.2)	1100 (124.3)	1100 (124.3)	1100 (124.3)
			1000 RPM	2000 RPM	3000 RPM
SLG115	4:1	4696(530.4)	1392 (157.3)	1132 (127.9)	1000 (112.9)
	5:1	4066 (459.4)	1445 (163.3)	1175 (132.8)	1040 (117.5)
	10:1	2545 (287.5)	1660 (187.6)	1350 (152.6)	1200 (135.6)
	16:1	4696 (530.4)	2112 (238.6)	1714 (193.0)	1518 (171.0)
	20:1	4696 (530.4)	2240 (253.1)	1840 (207.9)	1620 (183.0)
	25:1	4066 (459.4)	2350 (265.5)	1900 (214.7)	1675 (189.2)
	40:1	4696 (530.4)	2800 (316.4)	2240 (253.1)	2000 (225.9)
	50:1	4066 (459.4)	2900 (327.7)	2350 (265.5)	2100 (237.3)
	100:1	2545 (287.5)	2500 (282.5)	2500 (282.5)	2400 (271.2)

SLM Radial Load

RPM	50	100	250	500	1000
SLM060 lbf (N)	250 (1112)	198 (881)	148 (658)	116 (516)	92 (409)
SLM090 lbf (N)	427 (1899)	340 (1512)	250 (1112)	198 (881)	158 (703)
SLM115 lbf (N)	579 (2576)	460 (2046)	339 (1508)	269 (1197)	214 (952)
SLM142 lbf (N)	1367 (6081)	1085 (4826)	800 (3559)	635 (2825)	504 (2242)
SLM180	2237 (9951)	1776 (7900)	1308 (5818)	1038 (4617)	824 (3665)

SLG Radial Load

RPM	50	100	250	500	1000
SLG060 lbf (N)	189 (841)	150 (667)	110 (489)	88 (391)	70 (311)
SLG090 lbf (N)	350 (1557)	278 (1237)	205 (912)	163 (725)	129 (574)
SLG115 lbf (N)	858 (3817)	681 (3029)	502 (2233)	398 (1770)	316 (1406)

Side load ratings shown above are for 10,000 hour bearing life at 25mm from motor face at given rpm.

Motor and Gearmotor Weight

	SLM/G060			SLM/G090			SLM/G115			SLM142	SLM180
	Motor	1 Stage	2 Stage	Motor	1 Stage	2 Stage	Motor	1 Stage	2 Stage	(gear stages not available on SLM142 and SLM180)	
1 Stack lbs (kg)	3.0 (1.4)	7.5 (3.4)	9.3 (2.4)	5.4 (2.4)	12.8 (5.8)	14.8 (6.7)	14.2 (6.4)	28 (12.7)	34 (15.4)	31 (14.0)	60 (27.2)
2 Stack lbs (kg)	4.1 (1.9)	8.6 (3.9)	10.4 (4.7)	7.8 (3.5)	15.2 (6.9)	17.2 (7.8)	22.0 (9.9)	35.8 (16.2)	41.8 (18.9)	39 (17.7)	82 (37.2)
3 Stack lbs (kg)	5.2 (2.4)	9.7 (4.4)	11.5 (5.2)	10.2 (4.6)	17.6 (7.9)	19.6 (8.9)	29.8 (13.5)	43.6 (19.8)	49.6 (22.5)	47 (21.3)	104 (47.2)
Brake		1.8 (0.8)			2.7 (1.2)			4.1 (1.9)		6.0 (2.7)	12 (5.4)

Motor Speed Designators

All Exlar T-LAM motors and actuators carry a standard motor speed designator as defined below. This is representative of the standard base speed of the motor, for the selected bus voltage.

If the model number is created and the location for the motor speed designator is left blank, this is the base speed to which each motor will be manufactured. The model number can also be created including this standard speed designator.

Exlar also provides the flexibility to manufacture all of its "T-LAM" products with special base speeds to match the customer's exact application requirements. This may be a higher than standard speed motor, or lower base speed than standard which will allow the customer to get the required torque at a speed optimized to their application and use the minimum amount of current from their amplifier.

The call-out for a special speed is configured in the model number by using a two digit code from 01-99. These numbers represent the number, in hundreds, of RPM that will be the base speed for the particular motor.

For example, an SLG090-010-KCGS-AB1-138-40 motor that normally has a 4000 rpm standard winding can be changed to a 3300 rpm winding by changing the -40, to a -33. It can be changed to a 5000 rpm winding by changing the -40 to a -50.

Changing this speed designator will change the ratings of the motor, and these must be obtained from your local sales representative. Also, it is not possible to produce every possible speed from -01 to -99 for each motor at each voltage so please contact your local sales representative for confirmation of the speed that is desired for the application.

Designator	Base Speed	Motor Series
-50	5000 rpm	SLM/SLG060
-40	4000 rpm	SLM/SLG090
-30	3000 rpm	SLM/SLG115
-24	2400 rpm	SLM142, SLM180
01-99	Special Speed, consult your local sales representative	

Motor Options

SLM/SLG motor options are described with a 3 digit code. The first digit calls out the stack length, the second the rated bus voltage, and the third the number of poles of the motor. Refer to the mechanical/electrical specifications for motor torque and actuator rated force.

IP Ratings

Please see page 26 for full description of IP Ratings.

8 Pole, Class 180 H

1 Stack		2 Stack		3 Stack	
118	115 Vrms	218	115 Vrms	318	115 Vrms
138	230 Vrms	238	230 Vrms	338	230 Vrms
158	400 Vrms	258	400 Vrms	358	400 Vrms
168	460 Vrms	268	460 Vrms	368	460 Vrms
1A8*	24 VDC	2A8*	24 VDC	3A8*	24 VDC
1B8*	48 VDC	2B8*	48 VDC	3B8*	48 VDC
1C8*	120 VDC	2C8*	120 VDC	3C8*	120 VDC

Refer to specification pages 79-83 for availability of 115V stators by configuration.

* Low voltage stators may be limited to less than catalog rated torque and/or speed. Please contact your local sales representative when ordering this option.

Housing/Special Options

G = Anodized Aluminum

F = Smooth White Epoxy

This option provides for an actuator coated with FDA approved white epoxy.

E = Electroless Nickel Plating

This option provides for a motor with electroless nickel plating.

SS = Stainless Steel Housing

This option provides a motor with all stainless steel construction. Housing dimensions for this option are not equal to the standard housing. Force, torque and current ratings are reduced 25% with this option. Please inquire with your local sales representative for dimensions and ratings.

HC = Type III Hard Coat Anodized, Class I

This option provides an actuator with type III hard coat anodized coating. Class I, no dye.

XH = Special Housing Option

Any housing option that is not designated by the above codes should be listed as XH and described at time of order. All special options must be discussed with your local sales rep.

HW = Manual Drive, Handwheel

This option provides a manual drive handwheel on the side of the motor. The handwheel has an engage/disengage lever that is tied to an interrupt switch. Not available on SLM/G060. Also not available with holding brake unless application details have been discussed with your local sales representative.

RD = Manual Drive, Rear Hex

This option provides a hex shaft at the rear of the motor for manual operation. The hex shaft is directly coupled to the motor and can be turned by hand with a compatible wrench. The hex shaft is enclosed by a sealed cap

during operation. This option is not available w/absolute feedback. If the application requires a brake, discuss manual drive use with your local sales representative.

SD = Manual Drive, Side Hex

This option provides a hex manual drive on the side of the motor. The hex can be turned by hand with a wrench. Not available on SLM/G060. Also not available with holding brake unless application details have been discussed with your local sales representative.

XL = Non-Standard Lubrication

This option provides for indication in the model number that the customer has specified a lubrication other than the standard provided by Exlar, Mobilith SHC220. Specials include other greases including JAX FG-2 food grade, Mobilgrease 28, or other non-standard grease.

SLM060

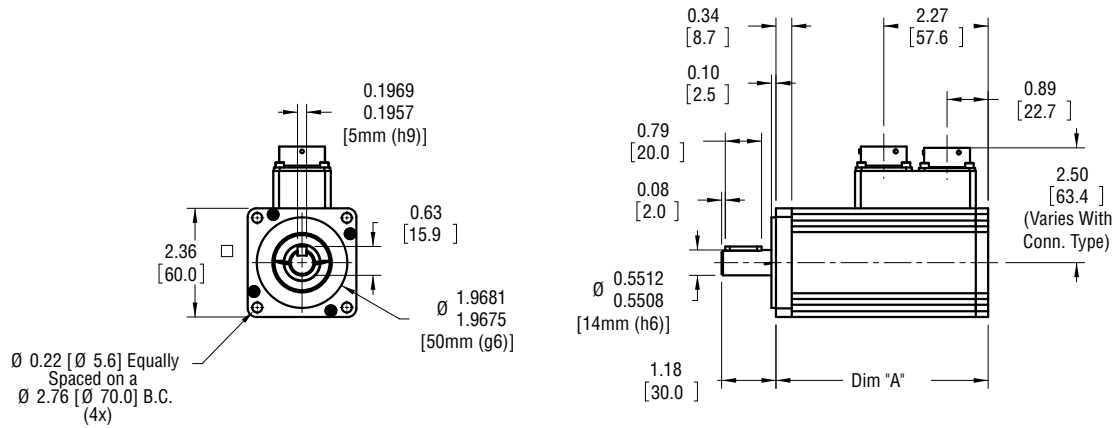

DIM	1 Stack Motor in (mm)	2 Stack Motor in (mm)	3 Stack Motor in (mm)
A	4.61 (117.1)	5.86 (149.9)	7.11 (180.6)

Face plate edge is not intended for alignment of shaft (use pilot)

SLM060 With Brake Option

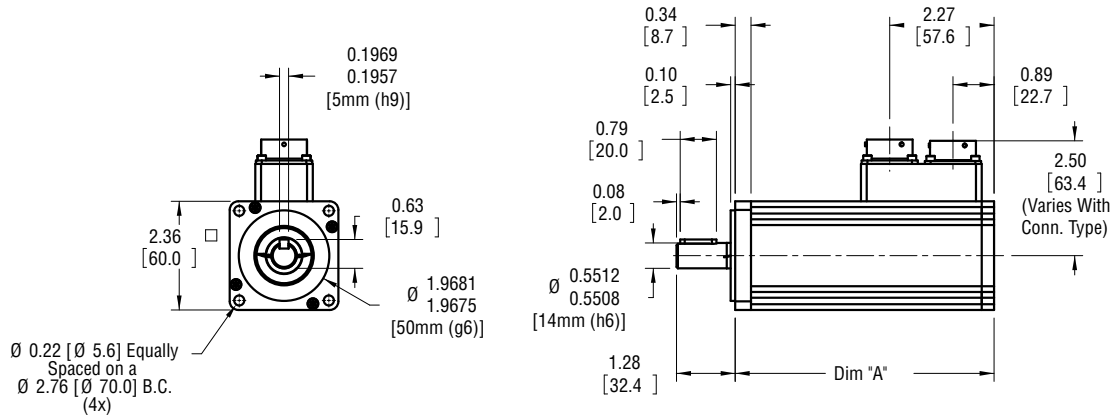

DIM	1 Stack Motor in (mm)	2 Stack Motor in (mm)	3 Stack Motor in (mm)
A	5.63 (143.0)	6.88 (174.7)	8.13 (206.4)

Face plate edge is not intended for alignment of shaft (use pilot)

Drawings subject to change. Consult Exlar for certified drawings.

SLM090

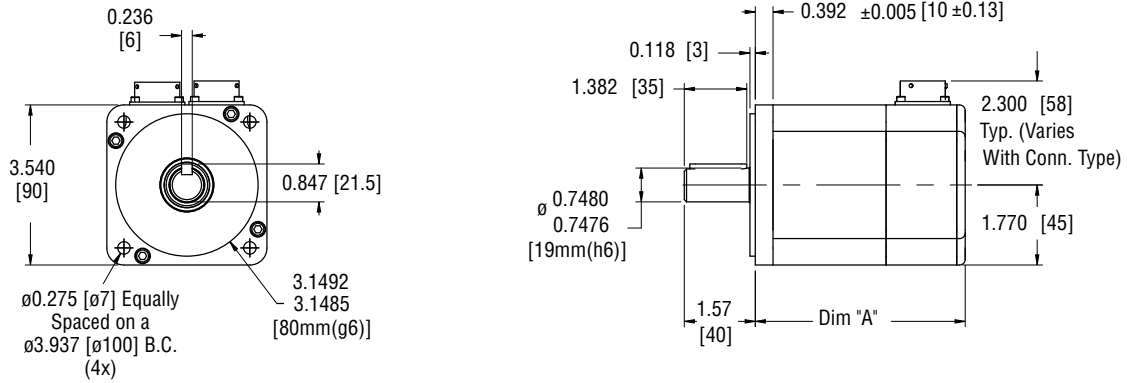

DIM	1 Stack Motor in (mm)	2 Stack Motor in (mm)	3 Stack Motor in (mm)
A	4.650 (118)	5.650 (144)	6.650 (169)

Face plate edge is not intended for alignment of shaft (use pilot)

SLM090 With Brake Option

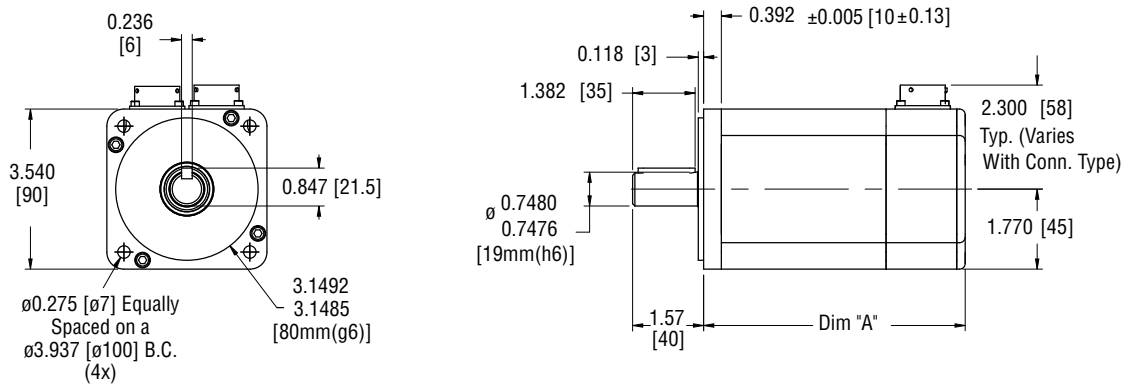

DIM	1 Stack Motor in (mm)	2 Stack Motor in (mm)	3 Stack Motor in (mm)
A	5.960 (151)	6.960 (177)	7.960 (202)

Face plate edge is not intended for alignment of shaft (use pilot)

Drawings subject to change. Consult Exlar for certified drawings.

SLM115

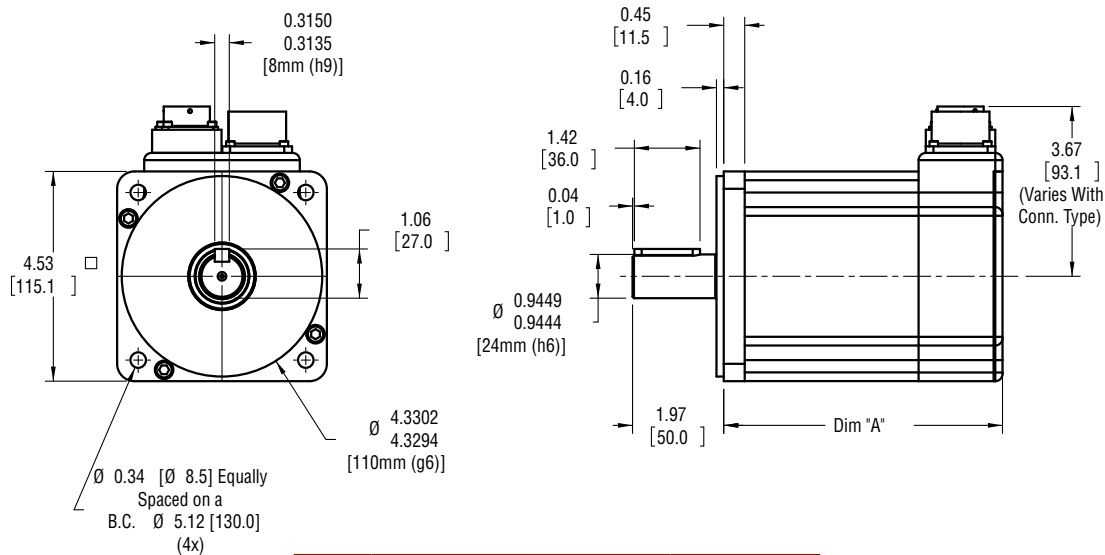

DIM	1 Stack—no brake in (mm)	2 Stack—no brake in (mm)	3 Stack—no brake in (mm)
A	6.02 (153.0)	8.02 (203.7)	10.02 (254.5)

Face plate edge is not intended for alignment of shaft (use pilot)

SLM115 With Brake Option

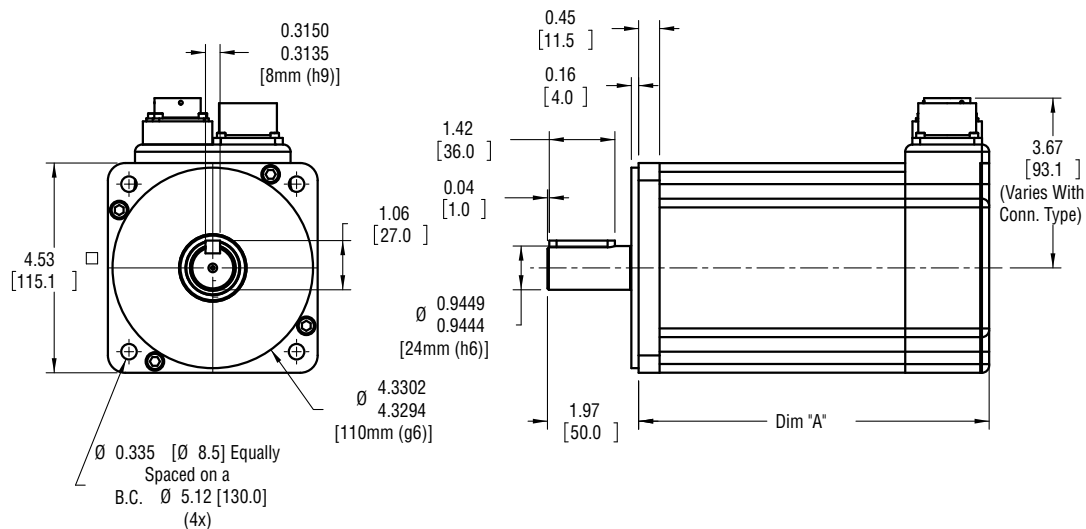

DIM	1 Stack—with brake in (mm)	2 Stack—with brake in (mm)	3 Stack—with brake in (mm)
A	7.75 (196.9)	9.75 (247.7)	11.75 (298.5)

Face plate edge is not intended for alignment of shaft (use pilot)

SLM142

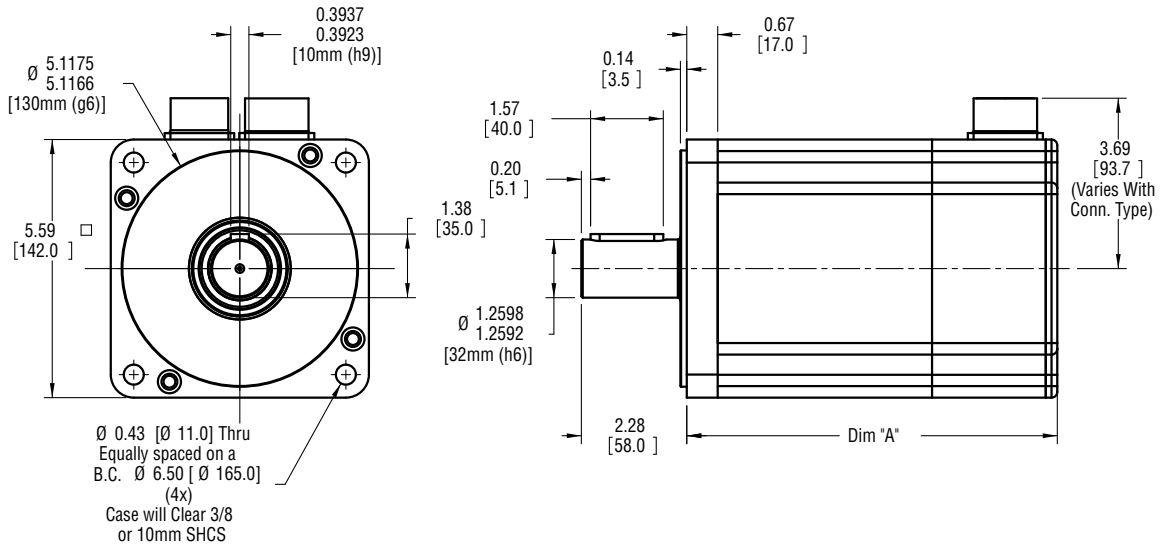

DIM	1 Stack—no brake in (mm)	2 Stack—no brake in (mm)	3 Stack—no brake in (mm)
A	7.87 (199.8)	9.62 (244.2)	11.37 (288.7)

Face plate edge is not intended for alignment of shaft (use pilot)

SLM/SLG
Series

SLM142 With Brake Option

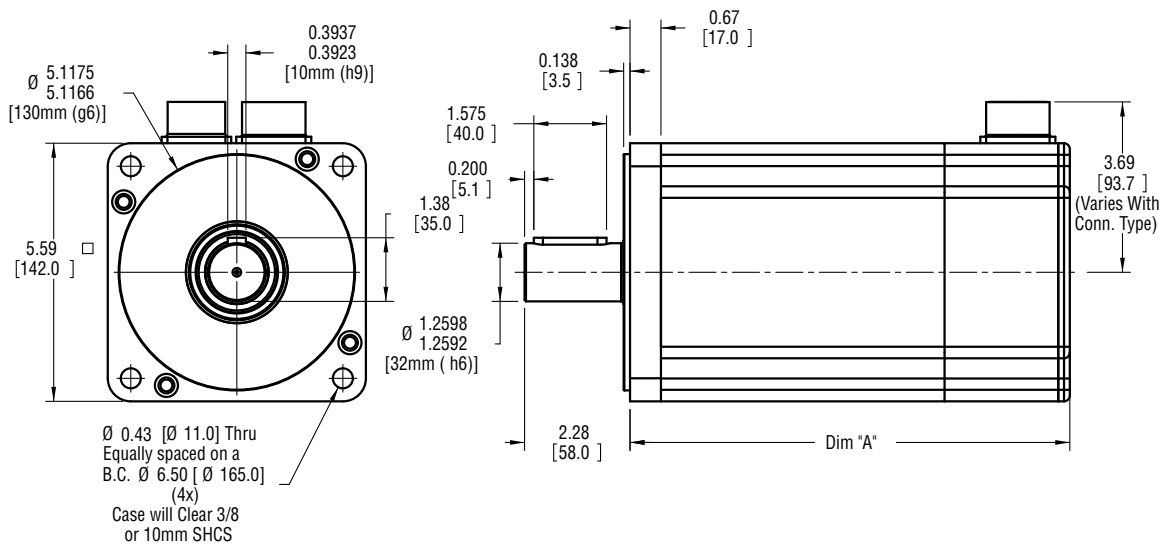

DIM	1 Stack—with brake in (mm)	2 Stack—with brake in (mm)	3 Stack—with brake in (mm)
A	9.53 (241.9)	11.28 (286.4)	13.03 (330.8)

Face plate edge is not intended for alignment of shaft (use pilot)

Drawings subject to change. Consult Exlar for certified drawings.

SLM180

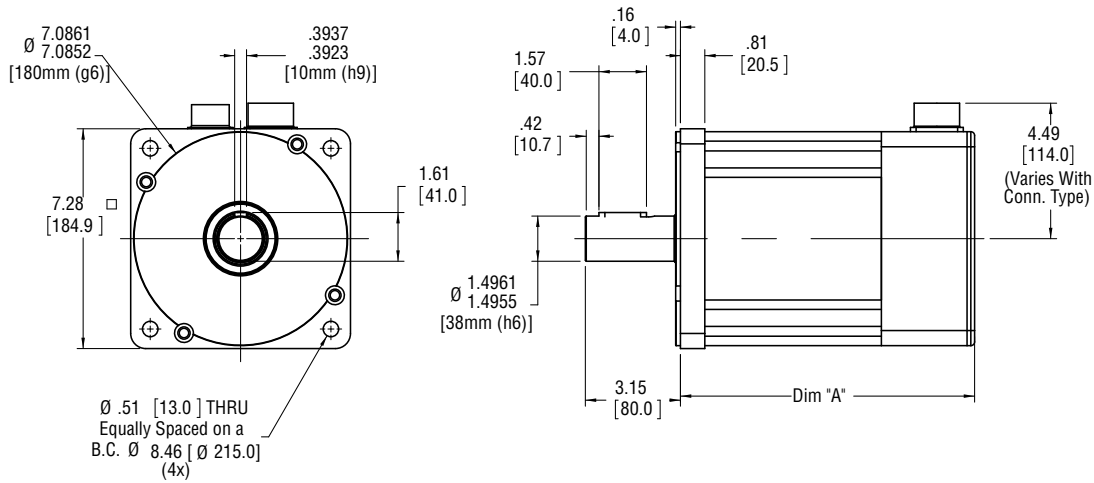

DIM	1 Stack-no Brake in (mm)	2 Stack-no Brake in (mm)	3 Stack-no Brake in (mm)
A	9.74 (247.5)	12.24 (310.9)	14.74 (374.4)

SLM180 With Brake Option

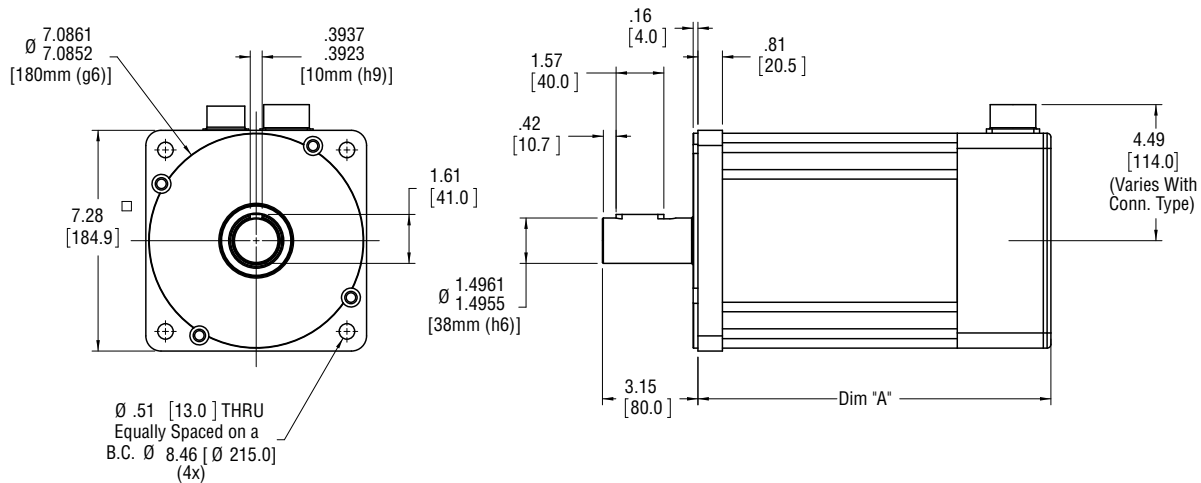

DIM	1 Stack-with Brake in (mm)	2 Stack-with Brake in (mm)	3 Stack-with Brake in (mm)
A	11.64 (295.7)	14.14 (359.2)	16.64 (422.7)

Drawings subject to change. Consult Exlar for certified drawings.

SLG060

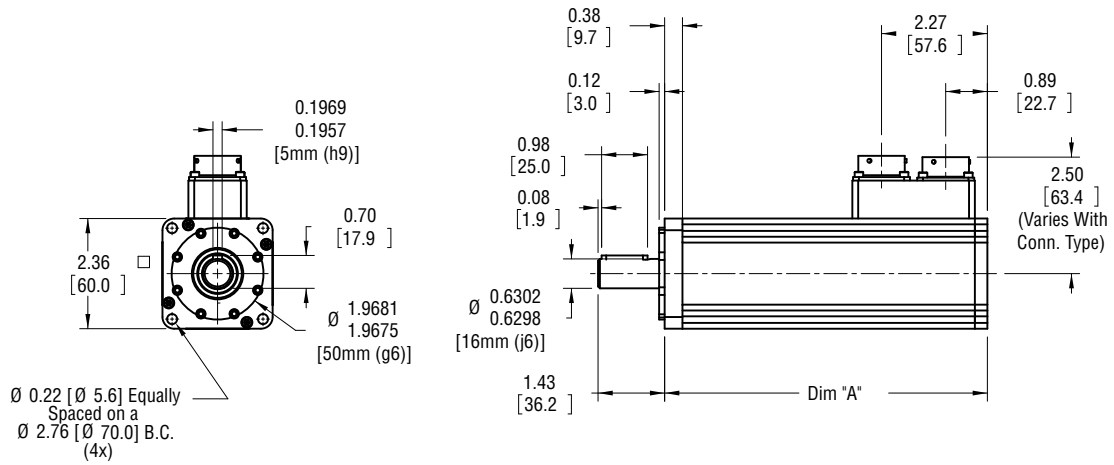

DIM	1 Stack Stator in (mm) 1 Stage Gearhead	2 Stack Stator in (mm) 1 Stage Gearhead	3 Stack Stator in (mm) 1 Stage Gearhead
A	6.915 (176)	8.165 (207)	9.415 (239)
	2 Stage Gearhead	2 Stage Gearhead	2 Stage Gearhead
	7.960 (202)	9.210 (234)	10.460 (266)

Face plate edge is not intended for alignment of shaft (use pilot)

SLG060 With Brake Option

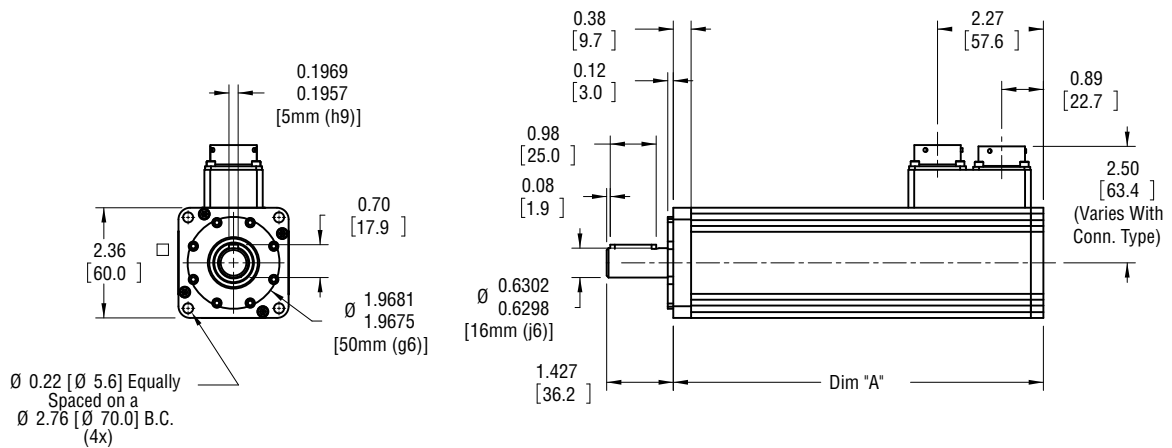

DIM	1 Stack Stator in (mm) 1 Stage Gearhead	2 Stack Stator in (mm) 1 Stage Gearhead	3 Stack Stator in (mm) 1 Stage Gearhead
A	7.930 (201)	9.180 (233)	10.430 (265)
	2 Stage Gearhead	2 Stage Gearhead	2 Stage Gearhead
	8.975 (228)	10.225 (260)	11.475 (291)

Face plate edge is not intended for alignment of shaft (use pilot)

SLG090

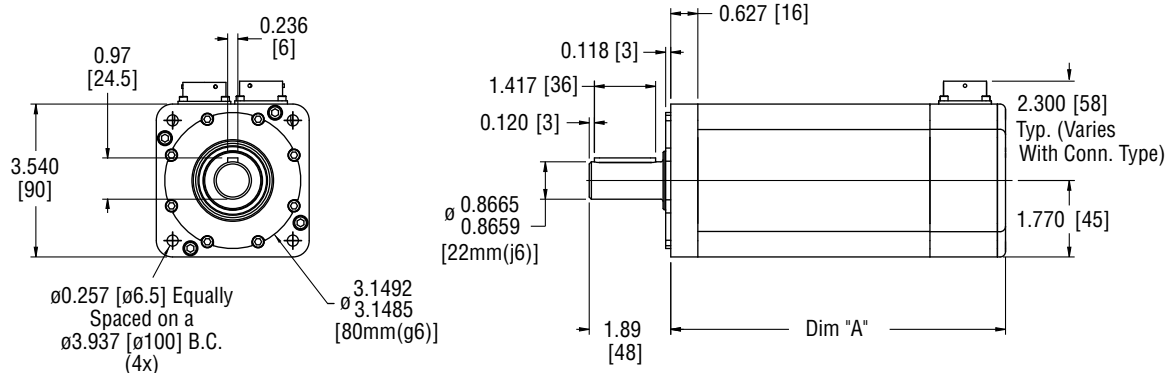

DIM	1 Stack Stator in (mm) 1 Stage Gearhead	2 Stack Stator in (mm) 1 Stage Gearhead	3 Stack Stator in (mm) 1 Stage Gearhead
A	7.760 (197)	8.760 (223)	9.760 (248)
	2 Stage Gearhead 9.025 (229)	2 Stage Gearhead 10.025 (255)	2 Stage Gearhead 11.025 (280)

Face plate edge is not intended for alignment of shaft (use pilot)

SLG090 With Brake Option

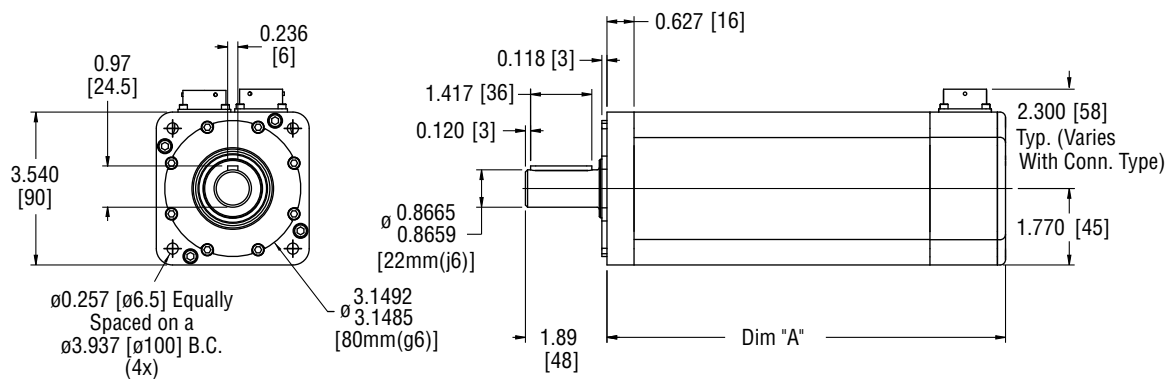

DIM	1 Stack Stator in (mm) 1 Stage Gearhead	2 Stack Stator in (mm) 1 Stage Gearhead	3 Stack Stator in (mm) 1 Stage Gearhead
A	9.070 (230)	10.070 (256)	11.070 (281)
	2 Stage Gearhead 10.335 (263)	2 Stage Gearhead 11.335 (288)	2 Stage Gearhead 12.335 (313)

Face plate edge is not intended for alignment of shaft (use pilot)

Drawings subject to change. Consult Exlar for certified drawings.

SLG115

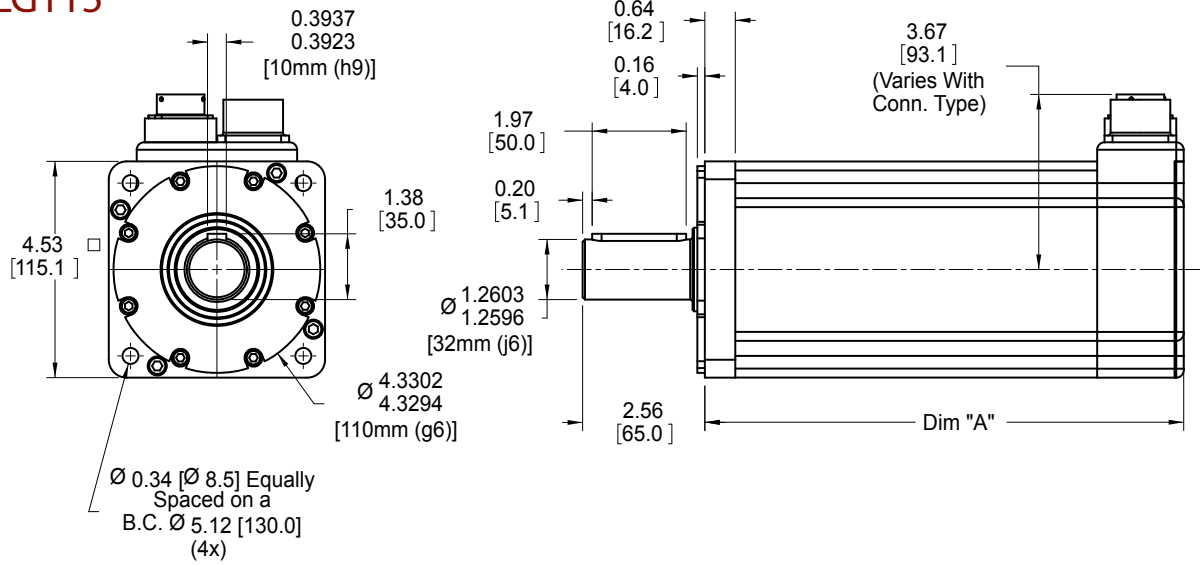

DIM	1 Stack Stator in (mm) 1 Stage Gearhead	2 Stack Stator in (mm) 1 Stage Gearhead	3 Stack Stator in (mm) 1 Stage Gearhead
A	10.03 (254.8)	12.03 (305.6)	14.03 (356.4)
	11.64 (295.7)	13.64 (346.5)	15.64 (397.3)

NOTE: Dimension format = in. (mm)
Face plate edge is not intended for alignment of shaft (use pilot)

SLG115 With Brake Option

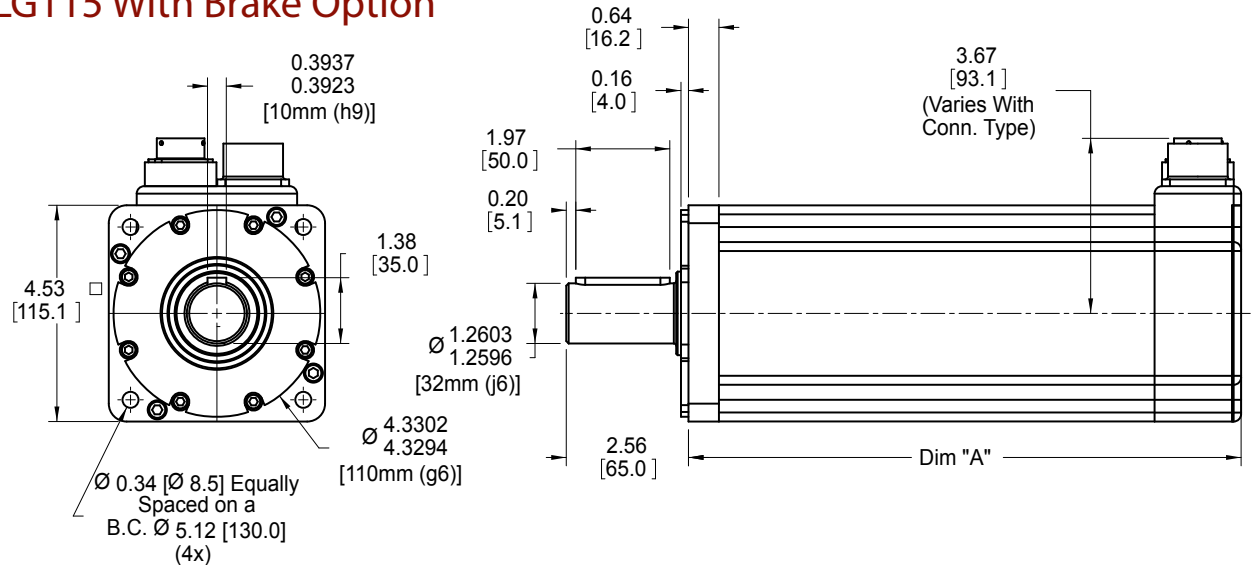

DIM	1 Stack Stator in (mm) 1 Stage Gearhead	2 Stack Stator in (mm) 1 Stage Gearhead	3 Stack Stator in (mm) 1 Stage Gearhead
A	11.58 (294.2)	13.58 (345.0)	15.58 (395.8)
	13.19 (335.1)	15.19 (385.9)	17.19 (436.7)

NOTE: Dimension format = in. (mm)
Face plate edge is not intended for alignment of shaft (use pilot)

Drawings subject to change. Consult Exlar for certified drawings.

SLM/G = Model Series

SLG = SLG Series Servo Gear Motor
 SLM = SLM Series Servo Motor
 (No Gear Reduction)

AAA = Frame Size

060 = 60 mm
 090 = 90 mm
 115 = 115 mm
 142 = 142 mm
 180 = 180 mm

BBB = Gear Reduction Ratio

Blank = SLM

Single reduction ratios

004 = 4:1
 005 = 5:1
 010 = 10:1

Double reduction ratios

016 = 16:1
 020 = 20:1
 025 = 25:1
 040 = 40:1
 050 = 50:1
 100 = 100:1

CC = Shaft Type

K = Keyed
 R = Smooth/round
 X = Special shaft

D = Connections

I = Exlar standard M23 style
 M = Manufacturer's connector²
 A = MS style (anodized)
 D = MS style (electroless nickel)
 B = Embedded leads 3 ft. std.
 P = Embedded leads w/plug
 3 ft. std.w/"A" plug
 J = Embedded leads w/"I" plug
 3 ft. standard
 X = Special (please specify)

E = Coating Options¹

G = Anodized Aluminum
 E = Electroless nickel plated
 F = Smooth white epoxy
 X = Special coating

F = Brake Options

B = Brake
 S = Standard no brake

GGG = Feedback Type (Also specify the Amplifier/Drive Model being used when ordering)

- Standard Incremental Encoder – 2048 line
 (8192 cts) per rev. index pulse, Hall
 commutation, 5vdc
 - Standard Resolver – Size 15, 1024 line
 (2048 cts) per rev. two pole resolver
 - Motor files for use with select Emerson/CT,
 Rockwell /AB and Danaher/Kollmorgen
 Drives are available at www.exlar.com

Custom Feedback - contact your local sales representative:

XX1 = Wiring and feedback device information
 must be provided and new feedback
 callout will be created

Allen-Bradley/Rockwell: (Actuators used with
 Kinetix and/or Sercos based control systems
 require a .cmf file from from AB/Rockwell.

Please contact your AB/Rockwell
 representative for support.)

AB8 = Standard Incremental Encoder – MPL
 Circular (Speedtec) DIN connectors for
 'M' option

AB9 = Hiperface Stegmann SRM050 absolute
 encoder – 115, 142, 180 Frame Size – MPL
 Circular (Speedtec) DIN connectors for 'M'
 option – Plug & Play feedback option⁷

ABB = Hiperface Stegmann SKM036 multi-turn
 absolute encoder. 60-90 Frame Size. MPL
 Circular (Speedtec) DIN connectors for
 'M' option – Plug & Play feedback option⁷

AMKASYN:

AK1 = EnDat Heidenhain EQN1325 multi-turn
 absolute encoder – 115, 142, 180 Frame
 Size. DS motor wiring w/M23 euro
 connectors for 'M' option

AK2 = EnDat Heidenhain EQN1125 multi-turn
 absolute encoder – 60-90 Frame Size.
 DS motor wiring w/M23 euro connectors
 for 'M' option

Advanced Motion Control:

AM1 = Standard Incremental Encoder
 AM2 = Encoder 1000 line, w/commutation,
 5 VDC

AM3 = Standard Resolver

AM5 = Encoder 5000 line, w/commutation,
 5 VDC

API Controls:

AP1 = Standard Resolver
 AP2 = Standard Incremental Encoder

Aerotech:

AR1 = Encoder 5000 line, w/commutation, 5 VDC
 AR2 = Standard Incremental Encoder

ABB Robot:

BB1 = LTN Resolver

Baldor:

BD2 = Std Resolver – BSM motor wiring
 w/M23 connectors for 'M' option
 BD3 = Std Incremental Encoder – BSM motor
 wiring w/M23 connectors for 'M' option

Beckhoff:

BE2 = EnDat Heidenhain EQN1125 multi-turn
 absolute encoder – AM5XX motor
 wiring w/M23 euro connectors for 'M'
 option

Baumuller:

BM2 = Standard Resolver

B&R Automation:

BR1 = Standard Resolver
 BR2 = EnDat Heidenhain EQN1325 multi-turn
 absolute encoder – 8LS/8LM motor wiring
 w/M23 euro connectors for 'M' option

Comau Robot:

CM1 = Standard Resolver

Copley Controls:

CO1 = Standard Incremental Encoder
 CO2 = Standard Resolver

Control Techniques/Emerson:

CT1 = Hiperface Stegmann SRM050 multi-turn
 absolute encoder – 115, 142, 180 Frame
 Size. FM/UM/EZ motor wiring w/M23
 euro connectors for 'M' option

CT3 = Hiperface Stegmann SKM036 multi-turn
 absolute encoder – 60-90 Frame Size.
 FM/UM/EZ motor wiring w/M23 euro
 connectors for 'M' option

CT4 = Standard Incremental Encoder –
 FM/UM/EZ motor wiring w/M23 euro
 connectors for 'M' option

CT5 = Std Resolver – FM/UM/EZ motor wiring
 w/M23 euro connectors for 'M' option

CT7 = Encoder 5000 line, with commutation,
 5 VDC – FM/UM/EZ motor wiring w/M23
 euro connectors for 'M' option

Delta Tau Data Systems:

DT1 = Encoder 1000 line, w/commutation, 5 VDC
 DT2 = Standard Resolver

Elmo Motion Control:

EL1 = Standard Resolver
 EL2 = Standard Incremental Encoder
 EL3 = EnDat Heidenhain EQN1125 multi-turn
 absolute encoder

Emerson/Control Techniques:

EM2 = Std Incremental Encoder – NT motor
 wiring w/MS connectors for 'M' option
 EM5 = Encoder 5000 line, with commutation,
 5 VDC – NT motor wiring w/MS
 connectors for 'M' option

Elau:

EU1 = Hiperface Stegmann SRM050 multi-turn
 absolute encoder – 115, 142, 180 Frame
 Size. SH motor wiring w/MS connectors
 for 'M' option

EU4 = Hiperface Stegmann SKM036 multi-turn
 absolute encoder – 60-90 Frame Size.
 SH motor wiring w/MS connectors for
 'M' option

Exlar:

EX4 = Standard Resolver

Fanuc Pulsecoder: Consult Exlar⁹

G&L Motion Control/Danaher Motion:

GL1 = Std Incremental Encoder – HSM motor
 wiring w/ MS connectors for 'M' option
 GL2 = Std Incremental Encoder – LSM-MSM
 motor wiring w/M23 euro connectors
 for 'M' option

GL3 = Std Incremental Encoder – NSM motor
 wiring w/MS connectors for 'M' option

GL4 = EnDat Heidenhain EQN1125 multi-turn
 absolute encoder – AKM motor wiring
 w/M23 euro connectors for 'M' option

Infranor:

IF1 = Standard Resolver

Indramat/Bosch-Rexroth:

IN6 = Std Resolver – MKD/MHD motor wiring w/M23 euro connectors for 'M' option

IN7 = Hiperface Stegmann SKM036 multi-turn absolute encoder – MSK motor wiring w/M23 euro connectors for 'M' option – plug & play option

Jetter Technologies:

JT1 = Standard Resolver – JH/JL motor wiring w/M23 euro connectors for 'M' option

Kollmorgen/Danaher:

KM4 = EnDat Heidenhain EQN1325 multi-turn absolute encoder – AKM motor wiring w/M23 euro connectors for 'M' option

KM5 = Standard Resolver – AKM motor wiring w/M23 euro connectors for 'M' option

KM6 = Standard Incremental Encoder – AKM motor wiring w/ M23 euro connectors for 'M' option

Kuka Robot:

KU1 = Tyco Size 21 Resolver⁹

Kawasaki Robot:

KW1 = Kawasaki Special Encoder⁹

Lenze/AC Tech:

LZ1 = Hiperface Stegmann SRM050 multi-turn absolute encoder – MCS motor wiring w/M23 euro connectors for 'M' option

LZ5 = Standard Resolver – MCS motor wiring w/ M23 euro connectors for 'M' option

LZ6 = Standard Incremental Encoder – MCS motor wiring w/ M23 euro connectors for 'M' option

Matuschek:

MC1 = LTN Resolver

Metronix:

MX1 = Standard Resolver

MX2 = Hiperface Stegmann SKM036 multi-turn absolute encoder

MX3 = EnDat Heidenhain EQN1125 multi-turn absolute encoder

Mitsubishi:

MT1 = Mitsubishi Absolute Encoder – HF-SP motor wiring with 'M' option

Modicon:

MD1 = Standard Resolver

Momentum:

MN1 = Hiperface Stegmann SRM050 multi-turn absolute encoder – MN motor wiring w/M23 connectors for 'M' option

MN2 = EnDat Heidenhain EQN1325 multi-turn absolute encoder – MN motor wiring connectors for 'M' option

MN3 = Std incremental encoder – MN motor wiring w/M23 connectors for 'M' option

MN4 = Std resolver – MN motor wiring w/M23 connectors for 'M' option

Moog:

MG1 = Standard Resolver

Motoman Robot:

MM1 = Yaskawa Serial Encoder⁹

Nachi Robot:

NC1 = Tamagawa Serial Encoder⁹

Ormec:

OR1 = Standard Resolver

OR2 = Std Incremental Encoder – G series motor wiring w/MS connectors for 'M' option

Parker Compumotor:

PC6 = Std Incremental Encoder – SMH motor wiring w/M23 connectors for 'M' option – European only

PC7 = Std Resolver – SMH motor wiring w/M23 connectors for 'M' option – European only

PC8 = Std Incremental Encoder – MPP series motor wiring w/PS connectors for 'M' option – US Only

PC9 = Hiperface Stegmann SRM050 multi-turn absolute encoder – MPP motor wiring w/PS connectors for 'M' option – US Only

PC0 = Std Resolver – MPP motor wiring w/PS connectors for 'M' option – US Only

Pacific Scientific:

PS2 = Standard Incremental Encoder

PS3 = Standard Resolver – PMA motor wiring w/M23 connectors for 'M' option

Stober Drives:

SB3 = EnDat Heidenhain EQN1125 multi-turn absolute encoder – ED/EK motor wiring w/M23 euro connectors for 'M' option

SB4 = Standard Resolver ED/EK motor wiring w/M23 connector for 'M' option

Siemens:

SM2 = Standard Resolver – 1FK7 motor wiring w/M23 connectors for 'M' option

SM3 = EnDat Heidenhain EQN1325 multi-turn absolute encoder – 115, 142, 180 Frame Size. 1FK7 motor wiring w/M23 euro connectors for 'M' option

SM4 = EnDat Heidenhain EQN1125 multi-turn absolute encoder – 60-90 Frame Size. 1FK7 motor wiring w/M23 euro connectors for 'M' option

SEW/Eurodrive:

SW1 = Standard Resolver – CM motor wiring w/ M23 euro connectors for 'M' option

SW2 = Standard Incremental Encoder

SW3 = Hiperface Stegmann SRM050 multi-turn absolute encoder – CM motor wiring w/ M23 euro connectors for 'M' option

Whedco:

WD1 = Standard Resolver

HHH = Motor Stator – All 8 Pole³

118 = 1 stack	115 Vrms	158 = 1 stack	400 Vrms
218 = 2 stack		258 = 2 stack	
318 = 3 stack		358 = 3 stack	
138 = 1 stack	230 Vrms	168 = 1 stack	460 Vrms
238 = 2 stack		268 = 2 stack	
338 = 3 stack		368 = 3 stack	

II = Optional Speed and Mechanical Designations

24 = 2400 rpm, SLM142 & 180

30 = 3000 rpm, SLM/G115

40 = 4000 rpm, SLM/G090

50 = 5000 rpm, SLM/G060

01-99 = Special speed, consult your local sales representative

XX = Part Number Designator for specials

HC = Type III hard coat anodized, class I¹

HW = Manual drive, handwheel with Interlock switch⁵

RD = Manual drive, Simple Rear⁵

SD = Manual drive, Side Hex

SS = Stainless steel housing^{1,8}

XH = Special housing or mounting option^{1,4}

XM = Special motor options

XF = Special feedback option

XL = Special lubrication, food grade or Mobilgrease 28, specify

XT = Special option

= Part No. Designator for Specials

Optional 5 digit assigned part number to designate unique model numbers for specials.

Note:

Any specials denoted by an X in the part number require definition and quotation from the factory.

- These housing options would typically be accompanied by the choice of the electroless nickel connectors if a connectorized unit were selected. Please inquire with your local sales representative.
- Available as described in Feedback Types.
- See page 85 for explanation of voltage, speed, stack and optimized stator options.
- When selecting special housing options, use "G" in this model mask location.
- Not available with absolute feedback.
- Not available on SLM/G060
- Not compatible with Kinetix 300 drives.
- Force, torque and current ratings are reduced 25% with this option.
- Requires Robot Vendor Approval and Support.