



**EMERSON**<sup>™</sup>  
Industrial Automation

## **Epsilon EP**

2.2A - 16A, 115V / 230V  
Compact 1.5-Axis  
Servo Drive Systems



# Compact, Powerful and Easy-to-Use Servo Drives

The Epsilon EP is a compact, easy-to-use Servo drive that is scalable from serving as a simple amplifier to a completely programmable axis-and-a-half motion controller. Available in Base, Indexer and Programming variants to meet a broad variety of application requirements, the Epsilon EP has models configured with fieldbus options and motion control capabilities that provide an excellent value for your motion control dollar.

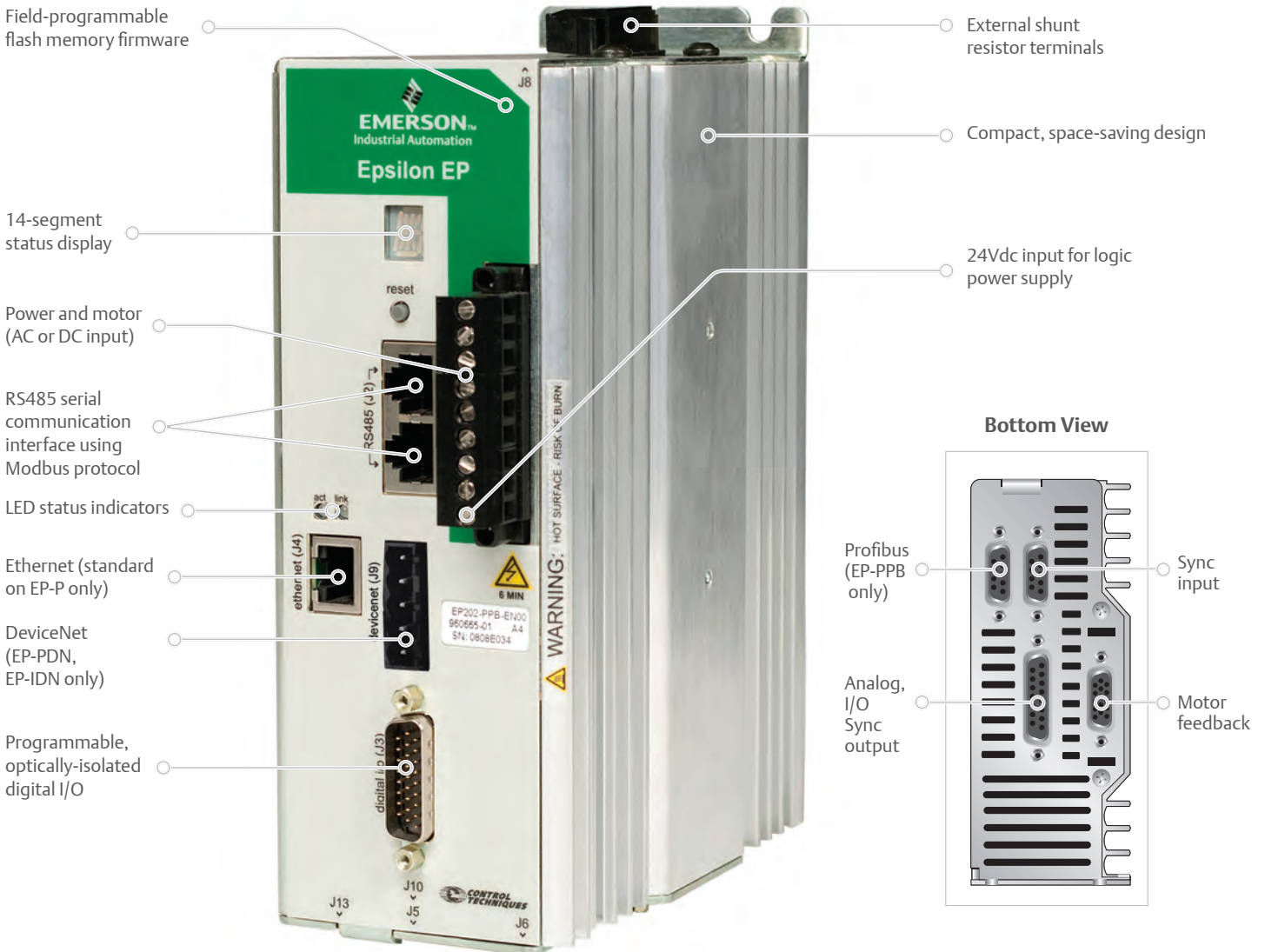

\*RoHS-compatible models are available.



# Rugged, Reliable Motion Control

## Good Things Come in Small Packages

Designed to fit in cabinets as small as six inches (152mm) deep (with cables attached), the Epsilon EP series is the most compact digital Servo drive in the Control Techniques product lineup. Though small in size, Epsilon EP drives possess the same rugged quality and reliability found in our larger drive series.

There are five sizes of each Epsilon EP drive: 2.2, 4, 6.5, 9 and 16A. The largest drive is capable of delivering up to 198lb-in (22.4Nm) continuous torque at rated motor speed. Each drive contains a 14-segment status display, reset button, removable connectors and utilizes standard “D-type” connectors.

A wide range of options are available allowing the user to customize the Epsilon EP variants to meet application requirements.

Epsilon EP Product Overview		
<b>Motors Controlled</b>	Servo motors, linear motors, linear actuators, gear motors	
<b>Control Modes</b>	Analog Velocity, Analog Torque, Digital Velocity Preset, Summation of A/D Velocity, Pulse/Pulse, Pulse/Direction, and Pulse/Quadrature. Indexing and programmable positioning, analog positioning - Position Tracker	
<b>Continuous Torque</b>	Up to 200lb-in	
<b>Continuous Current</b>	2.2A, 4A, 6.5A, 9A & 16A	
<b>AC voltage 50/60Hz ±10%</b>	90 to 264Vac 1Ø 208 to 240Vac 3Ø (Epsilon EP 216 only)	
<b>Motor Position Feedback</b>	Incremental encoders	
<b>Input/Output</b>	Input	Output
Digital: Indexer, Programmable	16	8
Digital: Base	5	3
Analog:	1	2
Pulse Single-Ended	1	--
Pulse Dif.	1	1
<b>Input/Output Options</b>	Via on-board MODBUS master (EP-P)	
<b>Communication</b>	MODBUS RTU standard all models	
	EP-I: Optional DeviceNet - EP-IDN	
	EP-P: Modbus TCP/IP & EtherNet/IP std.	
	Optional: Profibus DP (EP-PPB), DeviceNet (EP-PDN)	
<b>Configuration &amp; Programming</b>	CT PowerTools Pro	
<b>Approvals</b>	UL, CUL, RoHS (option), CE	

## Performance Advantage

Three configurations are available with built-in functionality (no add-ons required):

- EP-B Base — simple, for centralized control
- EP-I Indexing — point-to-point positioning applications
- EP-P Programming — sophisticated, multi-axis control

### EP-B Base: Multiple Operating Modes

Modes include Analog Torque, Analog Velocity, Position Tracker™ – Analog, Preset Velocity, Preset Velocity + Analog Velocity, Pulse/Pulse, Pulse/Direction and Pulse/Quadrature.

### EP-I Indexing: Simple, Powerful Capabilities

Sixteen indexes with chaining and linking capability, jogging, a multitude of homing routines, user units and Position Tracker™ (see page 5).

### EP-P Programming: Provides Advanced Capabilities

Complex functionality is easily achieved in the Epsilon EP-P programming environment including Position Tracker fieldbus indexing. Online help, application notes and programming examples are readily available. Capable of 1.5-axis control. Optional EP-PDN (DeviceNet), or EP-PPB (Profibus) are also available.

### FREE Software

Control Techniques' PowerTools Pro software uses drag-and-drop, fill-in-the-blank, point-and-click set-up, tabbed set-up screens and hierarchical views.

### Extensive Motors, Cables and Options

FM, HD, NT and XV Servo motors offer a wide range of inertia, torque, speed and cost; Pre-configured cables for easy installation.

### Easy-to-Use Communications

Systems include Modbus RTU (standard), EtherNet/IP, Modbus TCP/IP, Profibus and DeviceNet.

### Modbus Master

Supplements the drive's on-board I/O, manages a very large number of I/O and communicates updates to any Modbus follower device.

### Position Tracker™

Analog and fieldbus position control brings low-cost closed-loop feature onboard the drive. “Teach” function reduces set-up time.

### Timers

Up to eight different timer types to match your needs.

### Ethernet Programming

EP-P drive uses common Ethernet protocols for all levels of networking.

# Select the Epsilon EP That Meets Your Needs

## Application Solutions from Simple to Complex

Three functional configurations are available to meet a wide variety of applications.



### Base: Epsilon EP-B

This base drive is ideal for servo applications utilizing an external motion controller. It accepts an analog command signal and sends out position feedback. The EP-B has the unique capability of combining an analog command with a preset velocity for trimming or advance/decel operations. The EP-B drive is an excellent choice for stepper replacements or centralized control systems.

### Indexer: Epsilon EP-I or EP-IDN (DeviceNet)

The EP-I drive is a highly capable position controller that provides Home, Index and Jog motion profiles. The EP-I holds up to 16 unique indexes that also can be chained together to create complex motion profiles. The EP-I has a unique alternate mode feature whereby it can perform an Index or Home function and then switch to an alternate control mode (such as analog torque, analog velocity, or pulse-follower mode) on the fly!

### Programming: Epsilon EP-P, EP-PDN (DeviceNet) and EP-PPB (PROFIBUS)

The EP-P drive provides the highest level of control by allowing the user to create complete user programs to sequence the motion control along with other machine functionality. Using Control Techniques' free PowerTools Pro configuration software, the EP-P can be used to solve the most complex motion applications and simplify set-up using simple drag-and-drop and fill-in-the-blank screens. Set the EP-P to be a Modbus master in order to control multiple combinations of EP-P, EP-B and EP-I drives, up to a total of 32 drives!

Epsilon EP Feature Matrix	Epsilon Model		
	EP-B	EP-I	EP-P
Velocity Summation	✓		✓
Analog Position	✓	✓	✓
Analog Velocity	✓	✓	✓
Pulse Follower	✓	✓	✓
Analog Torque	✓	✓	✓
Preset Velocity / Jog	✓	✓	✓
Torque Limits	✓	✓	✓
Software Travel Limits		✓	✓
Homing		✓	✓
Indexing		✓	✓
Index Chaining		✓	✓
Compound Indexing		✓	✓
Synchronized Motion			✓
Gearing			✓
Camming			✓
Timed Index			✓
Multiple Profile Summation			✓
Queuing			✓
Feedhold			✓
Feedrate Override			✓
Programmable Limit Switches			✓
Auto-tune	✓	✓	✓
Software Oscilloscope	✓	✓	✓
Software Watch Window	✓	✓	✓
Status Display	✓	✓	✓
User Inits		✓	✓
User Variables			✓
User Programs			✓
Cyclical Programs			✓
Real-Time Programs			✓
Program Multitasking			✓
Timers			✓
High-Speed Position Capture			✓
Modbus RTU	✓	✓	✓
DeviceNet		Opt	Opt
Profibus-DP			Opt
EtherNet/IP			✓
Modbus TCP/IP			✓
Modbus Master			✓
Modbus Bridge/Gateway			✓
Web Page			✓
E-mail			✓
Position Tracker - Analog	✓	✓	✓
Position Tracker - Fieldbus		✓	✓

# Powerful Features for Powerful Solutions

## Advanced Features

### Real-Time Programs (EP-P)

A Real-Time Program (RTP) is a user program that executes to completion in every servo update period. RTPs allow for synchronous execution of external I/O updates, communications routines or external PI control loops. They can even be used for creating motion profile modifications while the application is running.

### Camming (EP-P)

Programming electronic camming is now easier than ever with Control Techniques' straightforward camming function. Execute a variety of cam profiles without having to write a single line of program code. For advanced capabilities, user programs can access a wealth of cam information for unprecedented flexibility. Cam motion can be dynamically monitored and easily modified on-the-fly.

### Modbus Master (EP-P)/Modbus Follower (EP-I, EP-B)

No longer limited to the drive's on-board I/O, the Modbus Master feature can manage a very large number of I/O and communicate updates to any Modbus follower device, giving machine builders extensive control options.

### Timers (EP-P)

Built-in timers provide a simple and accurate way to trigger an action based on a previously initiated time delay. Select from up to eight different timer types to match your needs.

### Ethernet Programming (EP-P)

The EP-P drive uses common Ethernet protocols for all levels of networking – to set up and monitor your application, communicate to PLC's via EtherNet/IP or connect to an operator panel using Modbus TCP/IP.

### Position Tracker™

Analog and fieldbus position control allow the Epsilon EP to replace an expensive PLC motion control module with a simple, low-cost analog signal or fieldbus register. With Position Tracker, the closed-loop feature of the position controller has been integrated into the drive itself. The user simply sends the drive an analog or fieldbus signal that is proportional to the absolute motor/actuator position. Advanced features, including Teach functions, help speed up installation and commissioning.

### Position Tracker – Analog Mode (EP-B, EP-I)

The advantage of the Position Tracker Analog Mode is that the drive can now use a simple and low-cost analog output module from a PLC (or analog joystick, potentiometer, lab view analog output, etc.) instead of a costly position control module. Analog mode includes several features that allow its intelligence to go beyond the initial set-up such as Mode Enable, Velocity Limits, Dead Band, Preset Calibration and Teach functions.

### Position Tracker – Fieldbus Indexing (EP-I, EP-P)

If you like the simplicity of analog position mode but require an optional command source, upgrade to the Position Tracker Fieldbus Indexing. This indexing option tracks the updated command and dynamically indexes the motor/load. Just send a single numeric value, using fieldbus communication of choice, to a predefined register and the motor will go to that position and hold its position until another command is sent. Commands can be sent on-the-fly even when the motor is in motion, positioning the motor to the latest command.

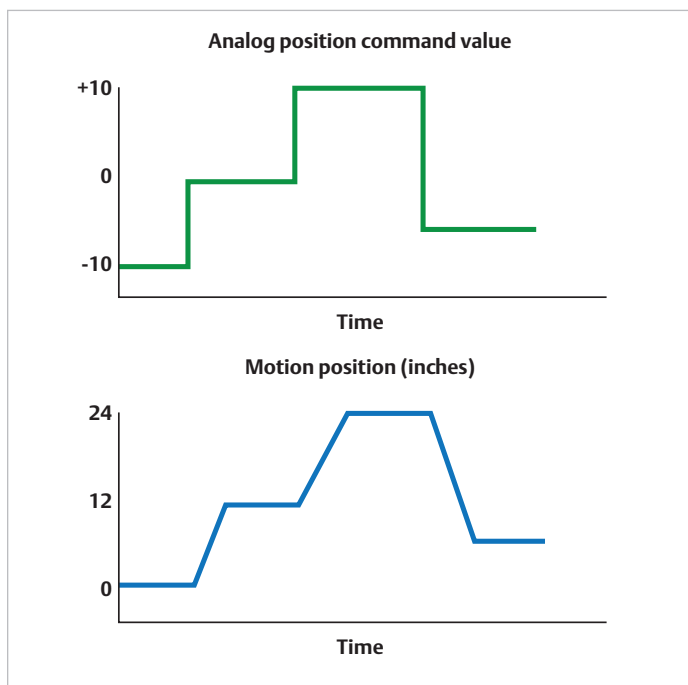

# Powerful Features for Powerful Solutions

## High-Speed Data Capture (EP-P)

Capture motor command position, motor position feedback, master position feedback and time within 1 microsecond after an event trigger! The High Speed Data Capture function (see Figure 1) has the functionality to initiate indexes or blended indexes and ensure that they are completed as calculated. This is achieved by internal operations that ensure the time line for motion execution is not broken and indexes automatically adjust for processor latencies.

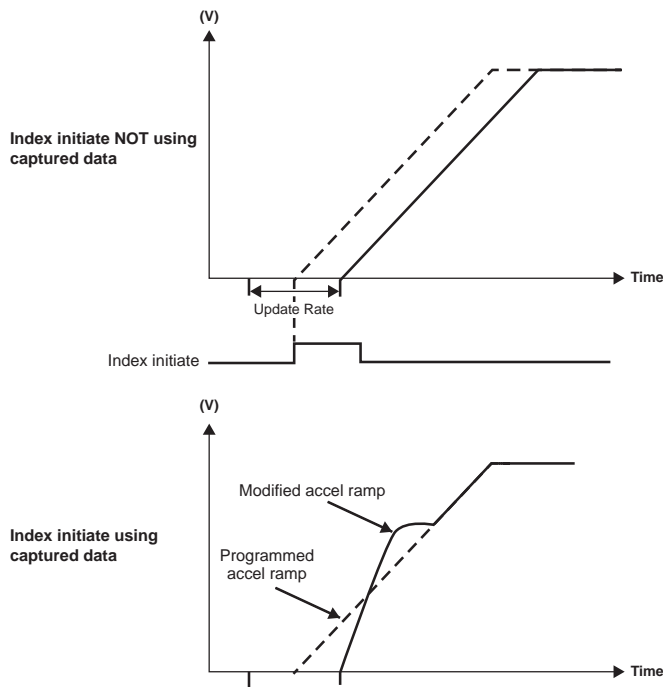
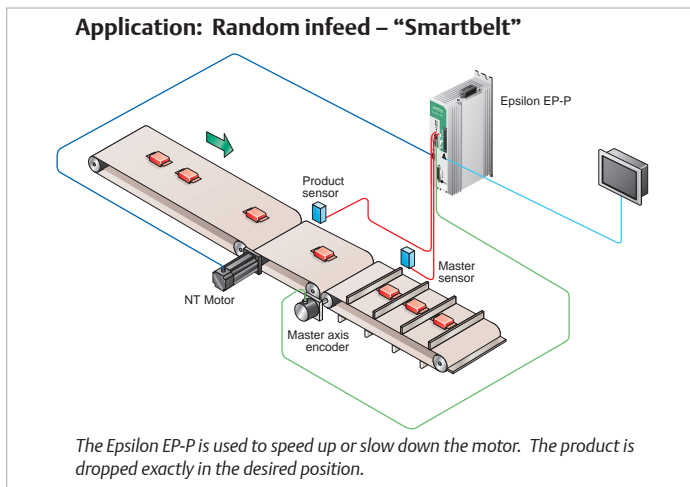

Figure 1



## PLS – Programmable Limit Switches (EP-P)

Refer to Figure 2. Up to 8 outputs can be triggered to “ON” based on motor or master encoder position range that is affected by motion in one direction, both directions or rotary rollover. Another mode of the PLS allows the output(s) to be triggered by time.

### Rotary rollover = 5

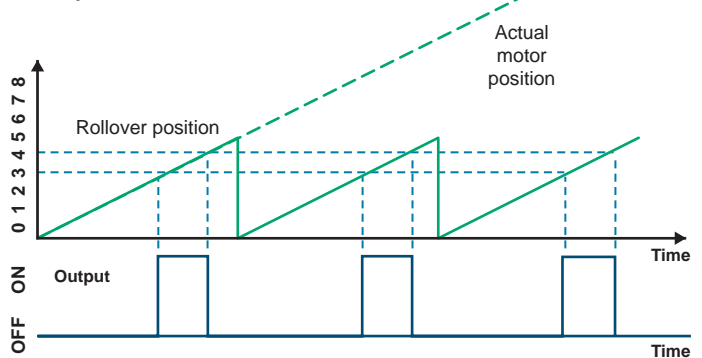

Figure 2

## Dual Loop Mode (EP-P)

For those applications where it is required to command motion based on feedback from a linear encoder, for example, PowerTools Pro has the functionality to configure the EP-P drive for Dual Loop mode. Whether the feedback is linear or rotary, a user can define motion in terms of the secondary feedback and let the Epsilon calculate the relative motion required by the motor.

## Feedrate/Feedhold (EP-P)

The Feedrate feature allows for adjustment of the motor velocity on-the-fly while the Feedhold feature allows for “Pause” of motion. Feedhold can be triggered by an input or event and motion stopped with a linear or S-curve deceleration, then started with a linear or S-curve acceleration. Motion stops in the middle of a motion profile and when started again will continue the interrupted motion profile.

## Queue Object (EP-P)

The Queue is used in applications where multiple products exist between the incoming product sensor and the location where the process takes place (i.e. applying labels, bar code printing, vision inspection, part rejection, etc.). Up to eight Queue objects can be used simultaneously to control all of the processes in your application.

## Web Browser (EP-P)

This view is used to access and set-up a password for a password-protected web page in the Epsilon EP-P drive.

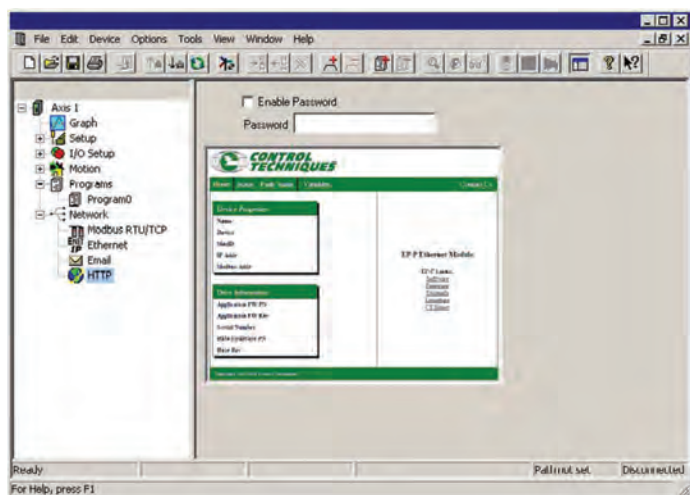

## Email View (EP-P)

The Email function allows a user to send a SMTP (email) message to one or more email addresses when initiated by a source or through a program. The Email view in the Network group on the hierarchy tree allows the user to set up the relay host, addresses, subject and text for the email message.

## Flexible I/O Functionality

The digital I/O of the drive is completely programmable with the ability to map one or more I/O functions to the I/O points.

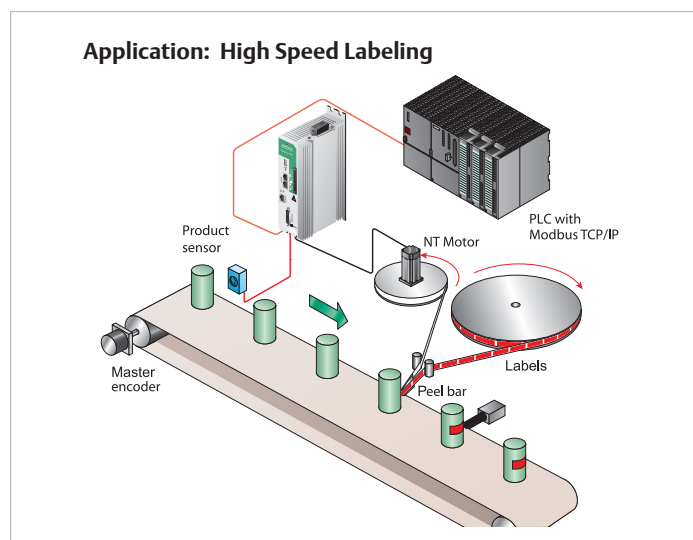

	Input Functions	Output functions
Base Functionality	Stop	Drive OK
	Reset	At Velocity
	Travel Limit (+ and -)	Travel Limits (+ and -)
	Torque Limit Enable	In Motion (+ and -)
	Torque Mode Enable	Power Stage Enabled
	Brake Release	Torque Limit Active
	Brake Control	Fault
	Enable Analog Position	Brake
	Teach Analog Position	Shunt Active
	Define Analog Position	Torque Level 1 Or 2 Active
Define Home	Foldback Active	
Velocity Presets (3) (EP-B only)	Power Module System Ready	
		Velocity Limiting Active (EP-B only)
Indexing Functionality*	Jog +	Torque at Max Velocity
	Jog -	Index in Position
	Jog Fast	Home Limit Distance Hit
	Index Initiate	End of Home
	Index Select 0	Absolute Position Valid
	Index Select 1	End of Index
	Index Select 2	End of Index Motion
	Index Select 3	End of Index Count
	Run Next Index	End of Chaining Counts
	Home Initiate	Registration Limit Distance Hit
	Home Sensor	
	Registration Sensor 1	
	Registration Sensor 2	
Repeat Current Index		

\* Indexing functionality includes all of Base functionality except where noted.

# Software Matched to Your Application Requirements



## “Motion Made Easy™”

Each step is configured using simple check boxes, drop-down selections and drag-and-drop functionality. A straightforward programming language allows users to develop more complex applications and advanced sequencing by simply dragging functions onto the work area and dropping them in place.

## PowerTools Pro Software for Epsilon EP

PowerTools Pro software provides configuration and advanced motion control programming for all Epsilon EP drives with the internal motion controller. This FREE software enables you to fully realize the power of the Epsilon EP motion controller. A familiar Microsoft® Windows® interface provides operators and machine builders with the tools needed to access everything they need for complete servo control – PLS, Queueing, High-Speed Capture, Electronic Gearing, Event Assignments and more.

Developing motion applications with PowerTools Pro is a simple “five-step, top-down” process. The five steps are displayed in a familiar “explorer” bar for easier navigation:

- Hardware configuration
- Drive setup
- Motion Programs
- I/O setup

• **Assignments** – Use “virtual wiring” to create programs right out of the box without writing a single line of code. For example, the assignment screen (below) allows you to drag-and-drop the desired machine function onto the digital inputs and outputs.

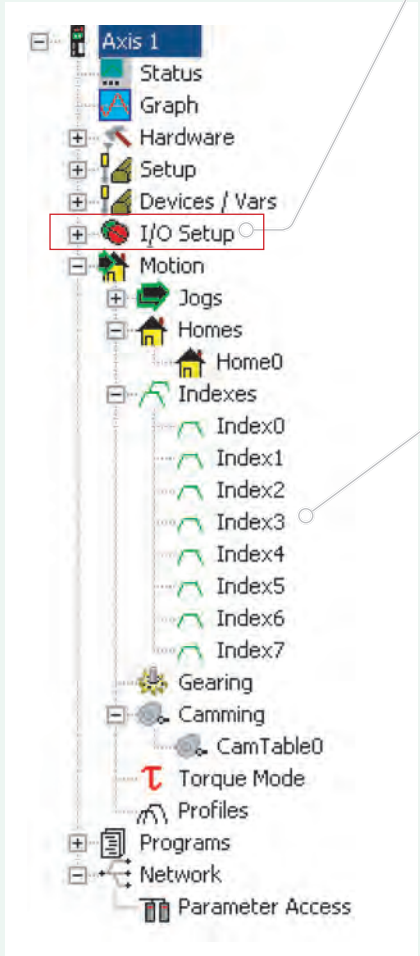

Source	Assigned to	Polarity	Destination	Set From	Polarity
InitiallyActive	PLS.0.PLSEnable	Active On	Outputs		
Index			DriveOutput.1	Index.0.AiVel	Active On
Cut	Index.0.AiVel	Active On	Index	PLS.0.Status	Active On
PLS	Index.0.CommandComplete	Active On	Retract	Index.0.CommandComplete	Active On
PLS0	PLS.0.Status	Active On	Home0	Index.0.Initiate	Active On
Inputs			Home0	Home.0.Initiate	Active On
DriveInput.1	Home.0.Initiate	Active On	Home0	Home.0.SensorTrigger	Active On
DriveInput.2	Home.0.SensorTrigger	Active On	PLS	DriveInput.1	Active On
DriveInput.3	MasterAxis.DefineHome	Active On	PLS0	DriveInput.2	Active On
	Stop	Active On	Ramps	PLS.0.PLSEnable	Active On
			Stop	InitiallyActive	Active On
			Master	DriveInput.3	Active On
			MasterAxis.DefineHome	DriveInput.2	Active On

• **Indexes** – Indexes are set up easily by filling in the screen’s blanks to create an index profile. Select from incremental, absolute, registration, or rotary plus and minus types. Choose the time base of the index by selecting either real-time or synchronized to a master. Over 100 user-defined indexes are available with the Epsilon EP.

Index Number	0	Distance	50.0000	revs
Index Name	Index0	Velocity	1500	revs/m
Index Type	Incremental	Acceleration	2000	revs/m/s
Time Base	Realtime	Deceleration	2000	revs/m/s
		<input type="checkbox"/> Timed	0.000	seconds
		<input type="checkbox"/> Enable Index PLS		
		PLS On Point	0.0000	revs
		PLS Off Point	0.0000	revs

  

Calculations   Registration			
Index Calculations			
Start Position	0.0000	Peak Velocity Attainable	1500
Index Distance	50.0000	Index Time	2.7500
Accel Distance	9.3750	Accel Time	0.7500
At Velocity Distance	31.2500	At Velocity Time	1.2500
Decel Distance	9.3750	Decel Time	0.7500

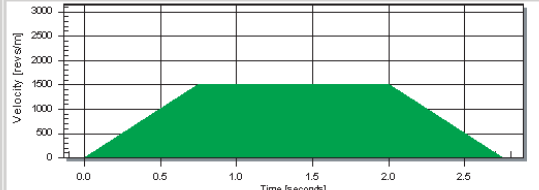

Microsoft and Windows are registered trademarks of Microsoft Corporation in the United States and other countries.



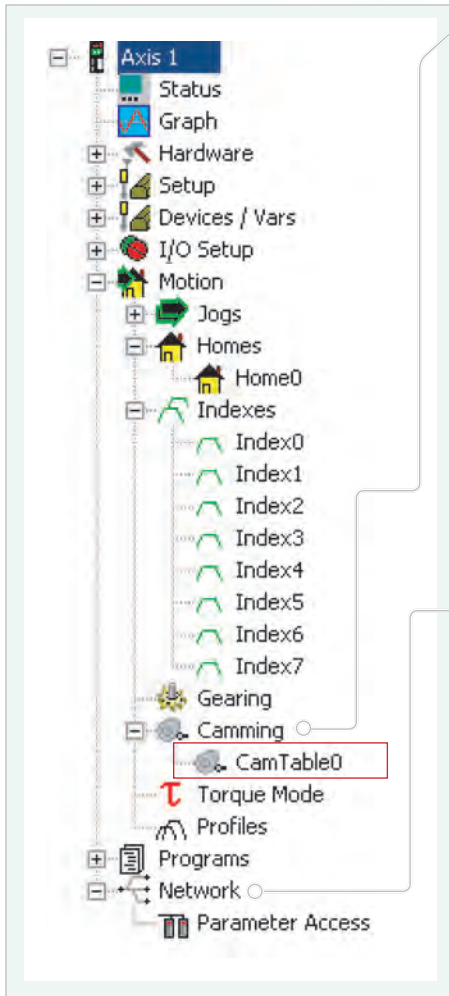

**Camming** – Cams make set-up and programming of complex motion profiles easy. The use of real-time programs provides smooth transitions when switching between cam profiles on-the-fly. Cam data is easily imported within PowerTools Pro and the cam graphing tool features multiple interpolation types.

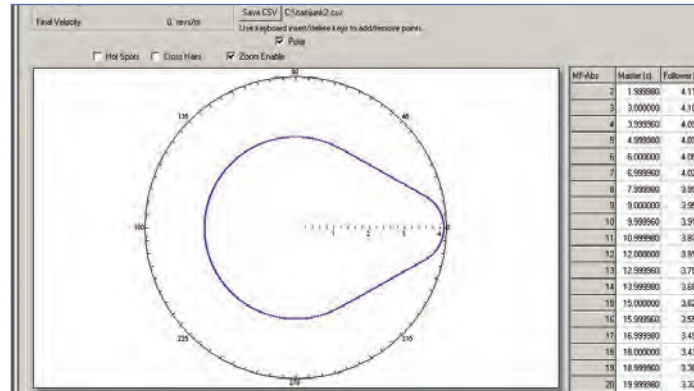

*Sophisticated motion routines such as camming, gearing or multiple profile summation are easily implemented with PowerTools Pro and Epsilon EP.*

**Network** – Whichever fieldbus is being used, setting up network communications is quick and easy. Fill-in-the-blank, drag-and-drop procedures are used to establish communication. PowerTools Pro's diagnostics allow monitoring of the actual data being sent and received.

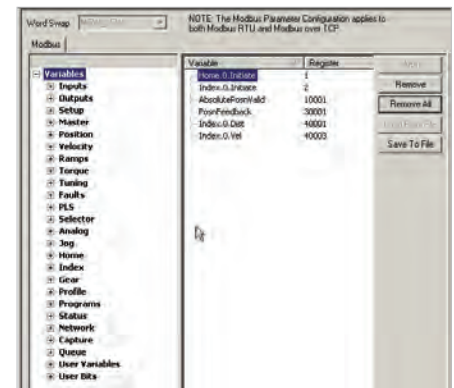

For more information on free software, please refer to the Software brochure. (BRO-SOFT-1107)



## Typical Applications

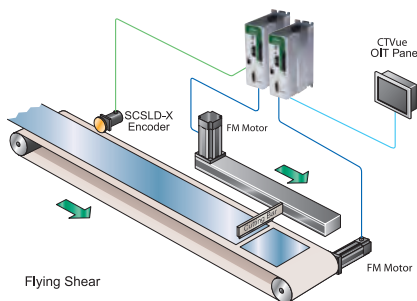

- Rotary knife
- Flying shear
- Pick and place machines
- Vertical or horizontal cartoners
- Traverse winders
- Form-fill-sealers
- Packaging systems
- Conveyor controls
- High speed labeling
- Random infeed – smart belt
- Phase synchronization
- Extend-retract
- Gluing applications
- Auger filler with analog weight check
- Semiconductor wet bath
- Dancer arm loop control
- Extruders

# Epsilon EP, Fast and Easy Integration Flexibility



Every Digitax ST drive includes FREE programming, configuration and sizing software.

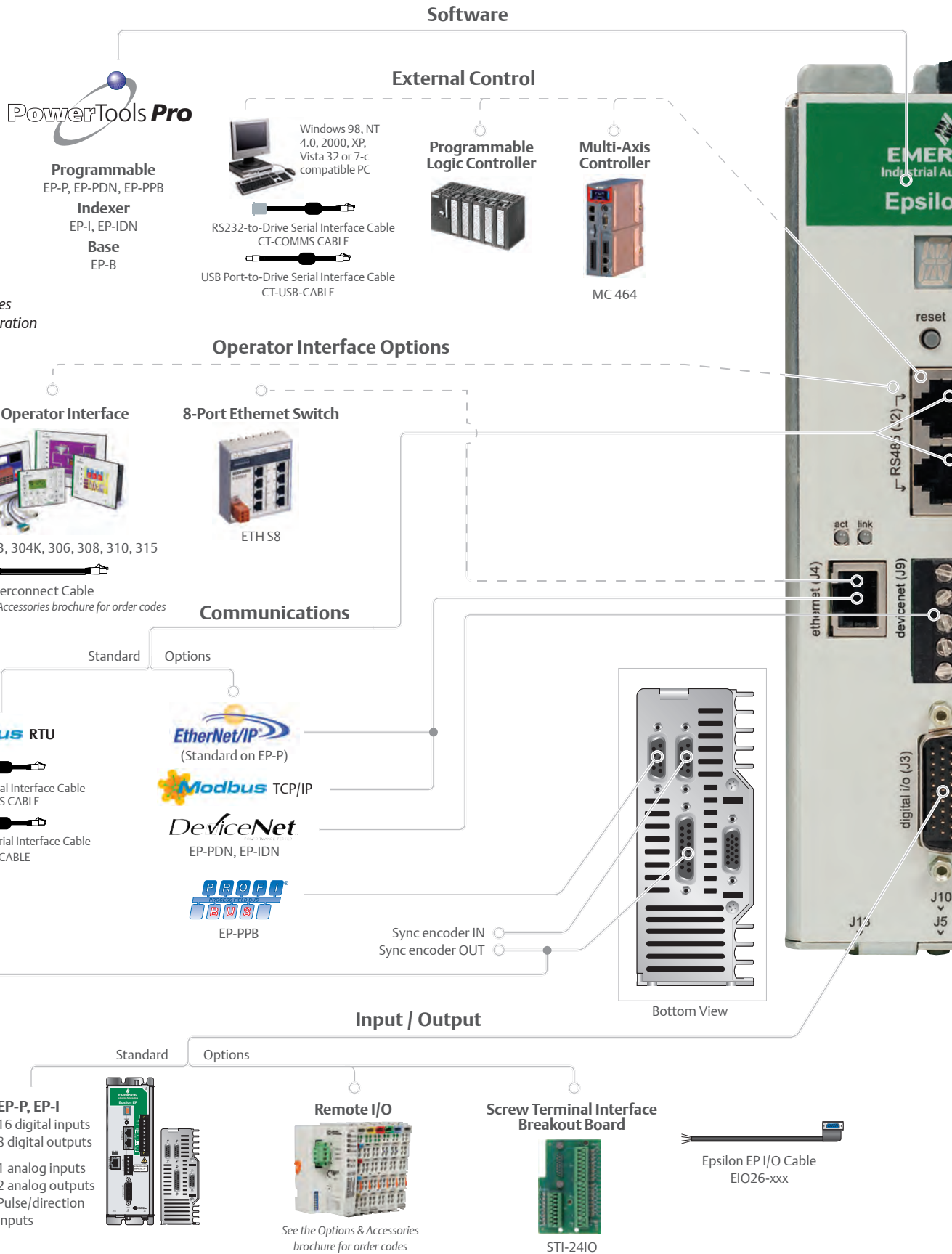

### Dynamic Braking Options

Filter (Option)

External EMC Filter



See the Options & Accessories brochure for order codes

Heatsink-Mounted Dynamic Braking Resistor



SM-HEATSINK-DBR0  
SM-HEATSINK-DBR1

External Dynamic Braking Resistor



See the Options & Accessories brochure for order codes

### Feedback

Standard Options

Master Synchronization Encoder



See the Options & Accessories brochure for order codes

Drive Sync Out Breakout Board



STI-SNCOA

Drive Sync In Breakout Board

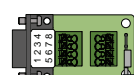

STI-SNCI

Motor Feedback Breakout Board

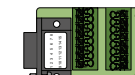

STI-ENC

Motor Feedback Breakout Board

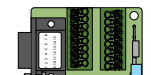

STI-ETC

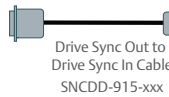

Drive Sync Out to Drive Sync In Cable  
SNRDD-915-xxx

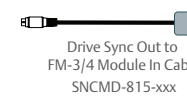

Drive Sync Out to FM-3/4 Module In Cable  
SNRMD-815-xxx

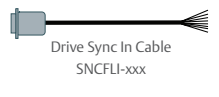

Drive Sync In Cable  
SNCFI-xxx

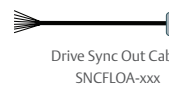

Drive Sync Out Cable  
SNCFLOA-xxx

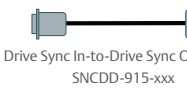

Drive Sync In-to-Drive Sync Out Cable  
SNRDD-915-xxx

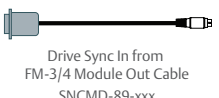

Drive Sync In from FM-3/4 Module Out Cable  
SNRMD-89-xxx

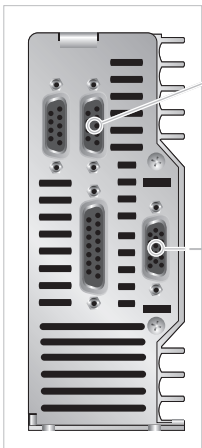

Bottom View

Logic Power Supply



24Vdc Control

See the Options & Accessories brochure for order codes

MOTOR FEEDBACK CONNECTION

### Servo Motors and Motor Cables

XV Motors



Motor Power Cable\*



Motor Feedback Cable\*

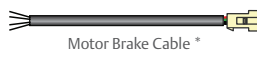

Motor Brake Cable\*

XV Motors 130mm



Motor Power Cable (+Brake)\*



Motor Feedback Cable\*

NT Motors



Motor Power Cable\*



Motor Feedback Cable\*

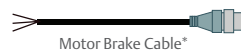

Motor Brake Cable\*

Unimotor FM

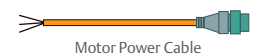

Motor Power Cable (+Brake)\*\*



Motor Feedback\*\*

Unimotor HD



External Drive Brake Relay  
24V, 1 CONTACT, 6A  
BRM-1

Cable Notes

\* Flex duty version available





\*\* Flex duty cable (standard)

## Motors to Match Your Application Needs

The Epsilon EP supports incremental feedback devices which are standard on all Control Techniques Servo motors. Control Techniques manufactures several matched motor solutions for Epsilon EP Servo drives and supplies a variety of gear reducers, actuators and other motion products through Control Techniques' One Source program. These drive-and-motor combinations provide an optimized system in terms of ratings, performance, cost and ease of use.



### Servo Motor Product Matrix

	HD Motors	NT Motors	XV Motors	FM Motors	MG Motors	MH Motors
<b>Motor Family</b>						
<b>Drive Family</b>	Unidrive SP Digitax ST Epsilon EP	Unidrive SP Digitax ST Epsilon EP	Unidrive SP Digitax ST Epsilon EP	Unidrive SP Digitax ST Epsilon EP	Unidrive SP Digitax ST Epsilon EP	Unidrive SP Digitax ST Epsilon EP
<b>Drive Voltage</b>	230/460	230	230	230/460	230	460
<b>Frame</b>	55, 67, 89, 115mm	2, 3in	40, 60, 80, 130mm	55, 75, 95, 115, 142, 190, 250mm	2, 3, 4in	3, 4, 6, 8in
<b>Flange</b>	IEC	IEC, NEMA	Metric	IEC	IEC, NEMA	
<b>Continuous Stall Torque</b>	Up to 166lb-in (18.8Nm)	Up to 56lb-in (6.3Nm)	Up to 101lb-in (11.4Nm)	Up to 1200lb-in (136Nm)	Up to 124lb-in (14Nm)	Up to 748lb-in (84.5Nm)
<b>Peak Torque</b>	Up to 499lb-in (56.4Nm)	Up to 144lb-in (16.2Nm)	Up to 301lb-in (34Nm)	Up to 1938lb-in (219Nm)	Up to 513lb-in (58Nm)	Up to 1600lb-in (182Nm)
<b>Base Speeds</b>	Up to 6000rpm	Up to 5000rpm	Up to 5000rpm	Up to 6000rpm	Up to 5000rpm	Up to 4000rpm
<b>Brake Options</b>	Holding, high energy dissipation			Holding		
<b>Connector Options</b>	Circular style frame mounted 90° and rotatable	MS or circular style frame mounted, MS style on 40° lead, flying leads, drive connector terminated leads (20 ft max.)	AMP Mat-n-Loc on 1 ft. lead (40-80mm); MS style frame mounted (130mm)	Circular style frame mounted 90° and rotatable; optional 90° fixed, vertical, or mixed	MS style frame mounted	
<b>Inertia</b>	Low	Low (high inertia opt.)	Low, Medium	Med. (high inertia opt.)	Medium	
<b>Feedback Options</b>	Incremental encoders, optical SinCos single & multi-turn, inductive SinCos single & multi turn, resolver, Hiperface (SICK) and EnDAT	Incremental 2048 line count, Inductive absolute, Resolver	Incremental 2048 line count	Incremental encoders, optical SinCos single & multi-turn, inductive SinCos single & multi turn, resolver, Hiperface (SICK) and EnDAT	Incremental 2048 line count	
<b>Ingress Protection</b>	IP65	IP65, IP67, IP68	IP55, IP65	IP65	IP65	
<b>Approvals</b>	CE, RoHS	CE, UL (RoHS opt.)	CE, UL, RoHS	CE, UL, RoHS	CE, UL	

# Selecting the Right Motor and Drive

Control Techniques drive-and-motor combinations provide an optimized system in terms of ratings, performance, cost and ease of use. Use Control Techniques' FREE CTSIZE software to select system components or manually select the system using the following steps.

1. Determine the application's continuous and peak torque requirements at various motor shaft speeds, then refer to motor data tables and the visual-reference overview on the facing page to help determine which motor family will be most appropriate for the application.
2. Once the motor family is selected, refer to the Control Techniques Servo Motors brochure (BRO-SRVOMTRS-1107) to select a specific motor that delivers the required torque and speed. Make note of the continuous and peak torque requirements of the selected motor.
3. Check the specification tables on pages 14-17 of this brochure to select the drive model that delivers adequate continuous and peak torque for the selected motor.

4. Go to the Control Techniques Servo Motors brochure to select motor power and feedback cables for the selected drive/motor combination.

For optimum performance, double-check that the rotor inertia ratio is <10 when calculated with the load inertia using the following equation:

$$\text{Load inertia/rotor inertia}$$

Note: A gear reducer will reduce the load inertia based on the following equation:

$$\text{Reflected load inertia} = \text{load inertia/gear ratio}^2$$

Note: EP-B, EP-I and EP-P can handle up to 50:1 inertia ratio effectively. When specifying a motor system, be sure to consider such factors as user-interface (HMI) options, braking resistors and other options and accessories that will enhance the system's performance and value.

## Example (using Unimotor HD family):

**Step 1:** The application requires 25lb-in continuous torque @ 2000rpm.

**Step 2:** The Control Techniques Servo Motors brochure lists the HD89EDB300 motor with 42.92 rated torque at 3000rpm. Select Epsilon EP drive-and-motor combination.

**Step 3:** Select the appropriate power and feedback cables.

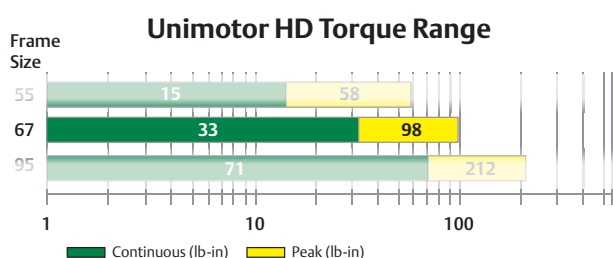

## Epsilon EP and Unimotor HD – 230V, 3Ø

Drive Model	Motor Model	Cont. Stall Torque lb-in (Nm)	Peak Torque lb-in (Nm)	Rated Torque @ Rated Speed lb-in (Nm)	Rated Power hp (kW)	Rated Operating Speed – rpm	Inertia lb-in sec <sup>2</sup> (kgm <sup>2</sup> )	Motor kt lb-in/Arms (Nm/Arms)
EP204	HD 67EDB600	16.46 (1.86)	32.92 (3.72)	16.46 (1.86)	1.56 (1.17)	6000	.00046 (.000053)	4.12 (.47)
EP206	HD 67EDB600	22.57 (2.55)	53.50 (6.05)	19.47 (2.20)	1.84 (1.38)	6000	.00046 (.000053)	4.12 (.47)
<b>EP206</b>	HD 89EDB300	48.68 (5.50)	107.00 (12.09)	<b>42.92 (4.85)</b>	2.03 (1.52)	3000	<b>.00142 (.000161)</b>	8.23 (.93)
EP209	HD 89EDC300	70.80 (8.00)	148.15 (16.74)	61.07 (6.90)	2.89 (2.17)	3000	.00207 (.000234)	8.23 (.93)
EP209	HD 115EDB300	74.07 (8.37)	148.15 (16.74)	68.15 (7.70)	3.22 (2.42)	3000	.00390 (.000441)	8.23 (.93)

# Matched Solution: Epsilon EP and Unimotor HD

## Unimotor HD 230V

The Unimotor HD is a high-dynamic servo motor range designed for maximum torque density. This brushless AC Servo motor range provides an exceptionally compact, low-inertia solution for applications where very high torque is required during rapid acceleration and deceleration profiles.

The Unimotor HD torque profile is closely matched to Epsilon EP Servo drives providing up to 200% peak overload for maximum dynamic performance. Unimotor HD incorporates a number of unique performance-enhancing design features.

- Torque range: up to 166lb-in (18.8Nm)
- High torque-to-inertia ratio for high-dynamic performance
- High-energy dissipation brakes

- Compact and powerful
- IP65 conformance, sealed against water spray and dust
- Supported by rigorous testing for performance and reliability

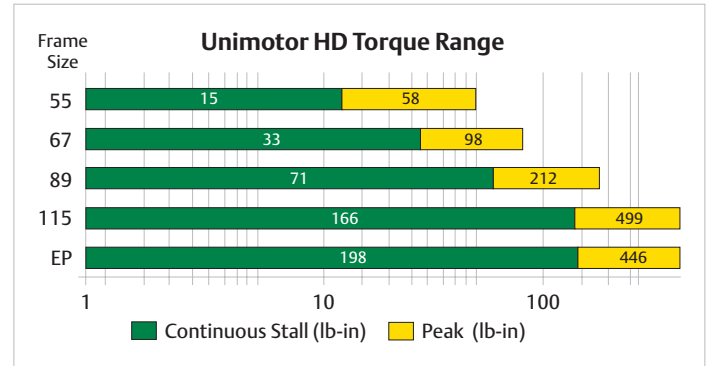

## Specifications

Epsilon EP and Unimotor HD – 230V, 3Ø								
Drive Model	Motor Model	Cont. Stall Torque lb-in (Nm)	Peak Torque lb-in (Nm)	Rated Torque @ Rated Speed lb-in (Nm)	Rated Power hp (kW)	Rated Operating Speed – rpm	Inertia lb-in sec <sup>2</sup> (kgm <sup>2</sup> )	Motor kt lb-in/Arms (Nm/Arms)
EP204	HD 67EDB600	16.46 (1.86)	32.92 (3.72)	16.46 (1.86)	1.56 (1.17)	6000	.00046 (.000053)	4.12 (.47)
EP206	HD 67EDB600	22.57 (2.55)	53.50 (6.05)	19.47 (2.20)	1.84 (1.38)	6000	.00046 (.000053)	4.12 (.47)
EP206	HD 89EDB300	48.68 (5.50)	107.00 (12.09)	42.92 (4.85)	2.03 (1.52)	3000	.00142 (.000161)	8.23 (.93)
EP209	HD 89EDC300	70.80 (8.00)	148.15 (16.74)	61.07 (6.90)	2.89 (2.17)	3000	.00207 (.000234)	8.23 (.93)
EP209	HD 115EDB300	74.07 (8.37)	148.15 (16.74)	68.15 (7.70)	3.22 (2.42)	3000	.00390 (.000441)	8.23 (.93)
EP216	HD 89EDC400	70.80 (8.00)	206.50 (23.33)	54.64 (6.17)	3.45 (2.58)	4000	.00207 (.000234)	6.20 (.70)
EP216	HD 115EDC300	129.21 (14.60)	263.40 (29.70)	92.93 (10.50)	4.40 (3.30)	3000	.00565 (.000639)	8.23 (.93)

NOTES: Drive switching frequency 10kHz unless noted; motors listed above are factory stock; refer to Servo Motors brochure for complete motor model number

## Order Information

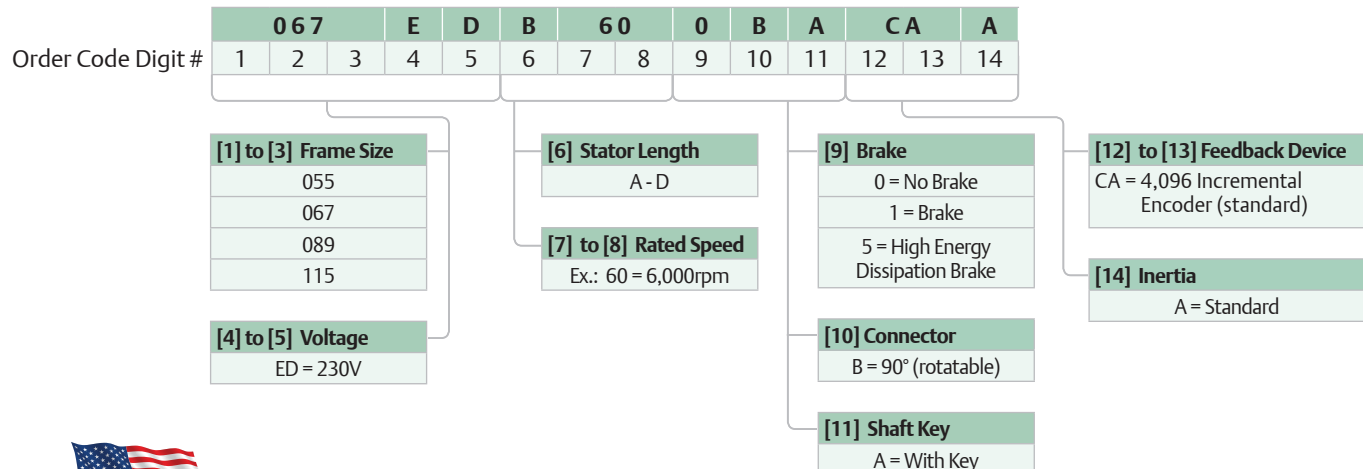

Assembled in the U.S.A.

# Matched Solution: Epsilon EP and NT Servo Motor

## NT Series Servo Motor 230V

The rugged NT motor is designed for the most stringent servo applications. Now available with multiple feedback options and white epoxy food-grade finish, the NT motor is an economical, high-performance motor made to maximize torque and minimize size. The NT motor uses powerful Neodymium magnets and is manufactured with a segmented core to maximize stator efficiency and further reduce size.

- Continuous torque range up to 56lb-in (6.3Nm)
- Peak torque over 2.5 X continuous torque
- Low-inertia, high-performance motor
- Rated speeds: 3000, 4000 and 5000rpm

- Frame sizes in English (NEMA 23 or 34) or Metric (IEC-72-1)
- Flying lead cabling options
- IP65, IP67 & IP68 rating, UL & CE compliant, RoHS optional

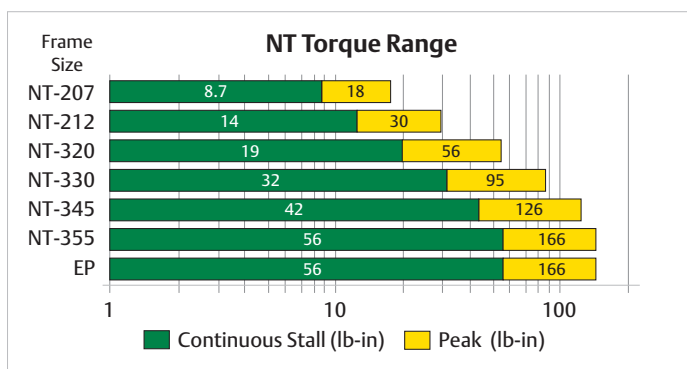

## Specifications

### Epsilon EP and NT Motor – 230V, 3Ø

Drive Model	Motor Model	Cont. Stall Torque lb-in (Nm)	Peak Torque lb-in (Nm)	Rated Torque @ Rated Speed lb-in (Nm)	Rated Power hp (kW)	Rated Operating Speed – rpm	Inertia lb-in sec <sup>2</sup> (kgm <sup>2</sup> )	Motor kt lb-in/Arms (Nm/Arms)
EP202	NT207	7.5 (.8)	22.5 (2.54)	7.3 (.82)	.58 (.43)	5000	.00009 (.000011)	5.12 (.58)
EP204	NT212	12.5 (1.4)	40.6 (4.58)	12.5 (1.41)	.99 (.73)	5000	.00016 (.000019)	5.08 (.57)
EP206	NT320*	19.7 (2.2)	45.5 (5.14)	16.0 (1.80)	1.02 (.76)	4000	.00033 (.000037)	3.5 (.40)
EP206	NT330*	31.5 (3.5)	65.52 (7.40)	31.5 (3.55)	2.00 (1.49)	4000	.00044 (.000049)	5.04 (.57)
EP206	NT345*	47.0 (5.31)	92.69 (10.47)	47.0 (5.31)	2.24 (1.67)	3000	.00067 (.000075)	7.13 (.81)
EP209	NT355	55.5 (6.27)	131.4 (14.84)	55.5 (6.27)	2.64 (1.96)	3000	.00089 (.000100)	7.3 (.82)

NOTES: Drive switching frequency 10kHz unless noted; motors listed above are factory stock; refer to *Servo Motors* brochure for complete motor model number  
 \* Available in medium inertia option

## Order Information

Order Code Digit #	1	2	3	4	5	6	7	8	9	10	11	12	13	14
	NT	M	2	12	C	0	N	S			0	0	0	0

**[1] to [2] Motor Family**  
NT = 230V

**[3] Mounting Flange**  
E = NEMA  
M = Metric (IEC-72-1)

**[4] Frame Size**  
2 = 2in NEMA 23  
3 = 3in NEMA 34

**[5] to [6] Torque Rating**  
07, 12, 20, 30, 45, 55

**[7] Connection Type**  
C = MS Connectors (IP65)  
T = MS Connector on Leads (IP65)  
L = Flying Leads, no connector (IP65)  
E = 90° Rotatable (IP67)  
F = Flying Leads w/white epoxy finish (IP68S)

**[8] Brake Option (24V)**  
0 = No Brake  
B = With Brake

**[9] Feedback Device**  
N = 2048ppr Encoder (std)

**[10] Inertia**  
S = Standard  
I = Medium

**[11] to [12] Flying Lead (opt)**  
00 = Standard  
DP = 15-pin D-sub feedback connector for direct connection to Epsilon EP and Unidrive SP

**[13] to [14] Flying Lead Length**  
00 = Standard  
05 = 5ft (+5-ft increments); max. length = 20ft

White epoxy food-grade option

Assembled in the U.S.A.

\* Bolt circle and shaft diameter are standard dimensions. See *Servo Motors* brochure for additional options.

# Matched Solution: Epsilon EP and XV Servo Motor

## XV Series Servo Motor 230V

The XV series Servo motors provide a low-cost, high-quality Servo motor solution for light industrial applications. The XV offers the smallest frame sizes of any Servo motors from Control Techniques starting at 40mm. This compact motor is a great solution for many servo applications and is also a good option for stepper motor replacements. XV Servo motors are available in 230Vac input voltage rating with a 2048ppr incremental encoder.

- Available in four frame sizes: 40, 60, 80 and 130mm
- Speed range from 2000 to 5000rpm

- Cost-effective replacement for stepper motor
- CE, UL and RoHS approved

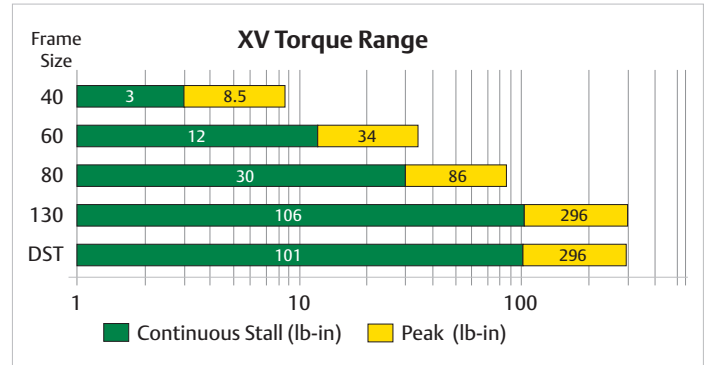

## Specifications

### Epsilon EP and Unimotor XV – 230V, 3Ø

Drive Model	Motor Model	Cont. Stall Torque lb-in (Nm)	Peak Torque lb-in (Nm)	Rated Torque @ Rated Speed lb-in (Nm)	Rated Power hp (kW)	Rated Operating Speed – rpm	Inertia lb-in sec <sup>2</sup> (kgm <sup>2</sup> )	Motor kt lb-in/Arms (Nm/Arms)
EP202	XV-402	1.41 (.16)	4.00 (.45)	1.41 (.16)	.07 (.05)	3000	.00002 (.000002)	1.24 (.14)
EP202	XV-403	2.81 (.32)	7.70 (.87)	2.80 (.32)	.13 (.1)	3000	.00004 (.000004)	2.21 (.25)
EP202	XV-606	5.70 (.64)	16.1 (1.82)	5.70 (.64)	.27 (.2)	3000	.00016 (.000018)	3.72 (.42)
EP204	XV-6011	11.2 (1.27)	32.3 (3.65)	11.2 (1.27)	.54 (.4)	3000	.00028 (.000032)	4.07 (.46)
EP204	XV-8017	16.9 (1.91)	39.7 (4.48)	16.9 (1.91)	.80 (.6)	3000	.00096 (.000109)	4.96 (.56)
EP204	XV-8023	23.3 (2.63)	51.0 (5.76)	23.3 (2.63)	.74 (.55)	2000	.00133 (.000151)	6.37 (.72)
EP206	XV-8028	28.1 (3.17)	71.5 (8.08)	28.1 (3.17)	1.34 (1.0)	3000	.00170 (.000192)	5.50 (.62)
EP206	XV-13046	46.5 (5.25)	97.5 (11.0)	46.5 (5.25)	1.48 (1.1)	2000	.01100 (.001245)	7.50 (.85)
EP206	XV-13051	50.7 (5.73)	148 (16.7)	50.7 (5.73)	.80 (.6)	1000	.01100 (.001245)	12.6 (1.42)
EP216	XV-13068	67.6 (7.64)	199 (22.5)	67.6 (7.64)	2.15 (1.6)	2000	.01530 (.001732)	7.40 (.84)
EP209	XV-13089	88.8 (10.0)	242 (27.4)	88.8 (10.0)	1.41 (1.05)	1000	.01530 (.001732)	13.5 (1.52)
EP209	XV-130101	101 (11.5)	245 (27.7)	101 (11.5)	1.61 (1.2)	1000	.02001 (.002265)	13.6 (1.54)

NOTES: Drive switching frequency 10kHz unless noted; motors listed above are factory stock; refer to Servo Motors brochure for complete motor model number

## Order Information

Order Code Digit #	XVM	60	11	C	B	N	S	0000			
	1	2	3	4	5	6	7	8	9	10	11
[1] Motor Family	XVM = 230V										
[2] Frame Size	40, 60, 80, 130mm										
[3] Torque Rating	40: 1, 2, 3 60: 4, 6, 11 80: 17, 22, 23, 28 130: 46, 51, 68, 89, 101										
[4] Connection Type	C = MS Connector (130 frame) T = AMP Connector on Leads (40-80 frame)										
[5] Brake (24V)	0 = No Brake B = With Brake										
[6] Feedback Device	N = 2048ppr Encoder										
[7] Inertia	S = Standard										
[8] to [11] Special Options	0000 = Standard										





# Matched Solution: Epsilon EP and Unimotor FM Servo Motor

## Unimotor FM Series Servo Motor 230V

Control Techniques' Unimotor FM series is designed to accommodate a wide range of applications with a highly configurable selection of feedback devices, shafts, inertias and more.

- Medium inertia
- IEC mounting (NEMA option on 95 and 142 only)
- Configuration options include brake, bolt circle, shaft diameter, plus high-peak and high-inertia options
- Multiple feedback options
- IP65 rating, UL, CE and RoHS compliant

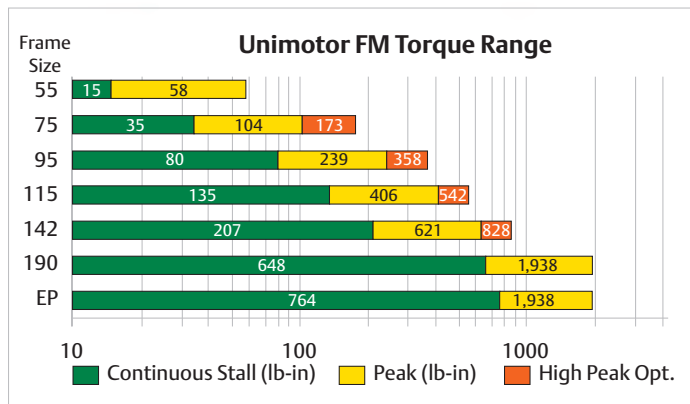

## Specifications

### Epsilon EP and Unimotor FM – 230V, 3Ø

Drive Model	Motor Model	Cont. Stall Torque lb-in (Nm)	Peak Torque lb-in (Nm)	Rated Torque @ Rated Speed lb-in (Nm)	Rated Power hp (kW)	Rated Operating Speed – rpm	Inertia lb-in sec <sup>2</sup> (kgm <sup>2</sup> )	Motor kt lb-in/Arms (Nm/Arms)
EP-202	075E2A40	10.62 (1.20)	25.49 (2.88)	8.85 (1.00)	.56 (.42)	4000	.00006 (.00007)	6.37 (.72)
EP-204	075E2B40	19.75 (2.23)	50.98 (5.76)	15.05 (1.70)	.95 (.71)	4000	.00106 (.00012)	6.37 (.72)
EP-204	075E2C40	25.49 (2.88)	50.98 (5.76)	20.36 (2.30)	1.28 (.96)	4000	.00141 (.00016)	6.37 (.72)
EP-204	075E2D30	32.92 (3.72)	65.84 (7.44)	30.98 (3.50)	1.47 (1.10)	3000	.00177 (.0002)	8.23 (.93)
EP-206	095E2B40	38.23 (4.32)	76.46 (8.64)	26.55 (3.00)	1.68 (1.26)	4000	.00256 (.00029)	6.37 (.72)
EP-209	095E2D30	66.67 (7.53)	148.15 (16.74)	60.18 (6.80)	2.85 (2.14)	3000	.00451 (.00051)	8.23 (.93)
EP-209	095E2D40	57.35 (6.48)	114.70 (12.96)	43.37 (4.90)	2.73 (2.05)	4000	.00451 (.00051)	6.37 (.72)
EP-209	095E2E30	74.07 (8.37)	148.15 (16.74)	71.69 (8.10)	3.39 (2.54)	3000	.00548 (.00062)	8.23 (.93)
EP-209	115E2C30	74.07 (8.37)	148.15 (16.74)	71.69 (8.10)	3.39 (2.54)	3000	.00796 (.0009)	8.23 (.93)
EP-216	115E2E30	131.69 (14.88)	263.38 (29.76)	111.51 (12.60)	5.28 (3.96)	3000	.01221 (.00138)	8.23 (.93)
EP-216	190E2B20	192.93 (21.80)	396.48 (44.80)	177.00 (20.00)	5.28 (3.96)	2000	.04310 (.00487)	12.4 (1.40)

NOTES: Drive switching frequency 10kHz unless noted; motors listed above are factory stock; refer to *Servo Motors* brochure for complete motor model number; EP-216 input is 3Ø

## Order Information

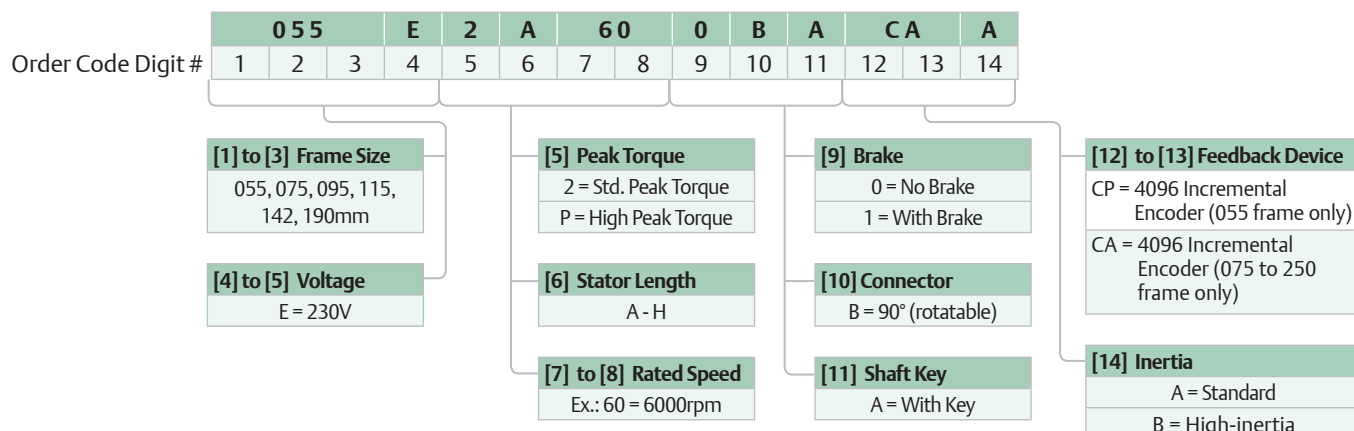

# Epsilon EP Drive Terminals and Pinouts

RS485 - Communications (J2)	
Pin #	Signal
1	120Ω Termination Resistor
2	RX TX
3	Isolated 0V
4	+15V
5	Isolated 0V
6	TX Enable
7	RX/ TX/
8	RX/ TX/ (if termination resistors are required, link to pin 1)
Shell	PE

Ethernet (J4) (EP-P ONLY)	
Pin #	Signal
1	TX+Ve
2	TX-Ve
3	RX+Ve
4	N/C
5	N/C
6	RX-Ve
7	N/C
8	N/C

DeviceNet (J9) (EP-PDN, IDN ONLY)	
Pin #	Signal
1	V-
2	CAN_L
3	Shield
4	CAN_H
5	V+

Profibus (J13) (EP-PPB ONLY)	
Pin #	Signal
3	B
8	A

Sync In (J10)	
Pin #	Signal
1	Encoder In A
2	Encoder In A/
3	Encoder In B
4	5Vdc
5	Encoder In B/
6	Encoder In Z
7	Encoder In Z/
8	Logic Common
9	N/C

Analog, Sync Out (J5)	
Pin #	Signal
1	Encoder Out A
2	Encoder Out B
3	Encoder Out Z
4	Pulse In
5	Analog In +
6	Analog Ground
7	Analog Out 1
8	Logic Common
9	Encoder Out A/
10	Encoder Out B/
11	Encoder Out Z/
12	Direction In
13	Analog In -
14	Analog Ground
15	Analog Out 2

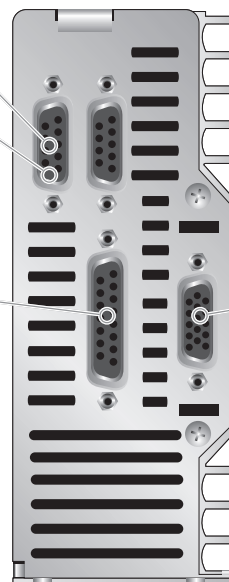
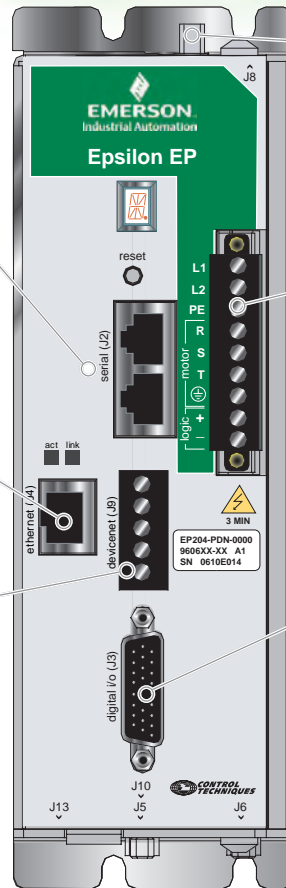

(Bottom View)

Shunt (J10)	
Pin #	Signal
1	B+
2	PE
3	SH
4	PE
5	B-

Power (J1)	
Pin #	Signal
L1	AC Input L1
L2	AC Input L2
PE	PE
Motor R	Motor Power R
Motor S	Motor Power S
Motor T	Motor Power T
Gnd	Motor Ground
Logic +	Logic +24Vdc
Logic -	Logic 0Vdc

Digital I/O (J3)	
Pin #	Signal
1*	Input 1
11*	Input 2
2*	Input 3
12*	Input 4
3	Input 5
13	Input 6
4	Input 7
14	Input 8
5	Input 9
15	Input 10
6	Input 11
16	Input 12
10*	Drive Enable
19	I/O + Vdc
20	I/O Common
7	Output 1
17	Output 2
8	Output 3
18	Output 4
9	Output 5
25	Output 6
26	Output 7
21	Output 8
22	Input 13
23	Input 14
24	Input 15

\*Epsilon EP-B includes these pinouts only

Motor Feedback (J6)	
Pin #	Signal
1	Encoder A
2	Encoder A/
3	Encoder B
4	Encoder B/
5	Encoder Z
6	Encoder Z/
7	Commutation U
8	Commutation U/
9	Commutation V
10	Commutation V/
11	Commutation W
12	Commutation W/
13	5Vdc Power
14	Ground
15	Motor OverTemp

# Epsilon EP Specifications and Dimensions

## Specifications

### Power Requirements

AC input voltage, 47-63Hz  
 EP 202/204/206: 1Ø, 20 to 264Vac  
 EP 209: 1Ø, 90 to 264Vac  
 EP 216: 1Ø/3Ø, 90 to 264Vac

(240Vac for rated performance) fault current 10kA

### DC input voltage

EP 202/204/206: 10 to 340Vdc  
 EP 209/216: 140 to 340Vdc

### AC input current (max. continuous)

EP-202: 5.0Arms (140A for 2ms inrush)  
 EP-204: 8.5Arms (140A for 2ms inrush)  
 EP-206: 12.0Arms (140A for 2ms inrush)  
 EP-209: 18Arms (34A for 5ms inrush)  
 EP-216: 36Arms (34A for 5ms inrush)

### Output current continuous (rms) / Peak (4 sec.)

EP-202: 2.2A / 4.4A  
 EP-204: 4.0A / 8A  
 EP-206: 6.5A / 13A  
 EP-209: 9.0A / 18A  
 EP-216: 16.0A / 32A

### Continuous output power

EP-202: 0.775kW  
 EP-204: 1.275kW  
 EP-206: 1.775kW  
 EP-209: 2.325kW  
 EP-216: 4.8kW

### Switching Frequency 10kHz

### External Logic Supply 24Vdc ± 10% @ 0.5A

### Encoder Supply Output +5Vdc, 250mA

### I/O Supply +10 to 30Vdc

### System Efficiency 93%

### Cooling Method Convection

### Regeneration

Internal energy absorption (115V / 230V)

EP-202: 39 Joules / 8 Joules  
 EP-204: 58 Joules / 12 Joules  
 EP-206: 97 Joules / 20 Joules  
 EP-209: 117 Joules / 24 Joules  
 EP-216: 132 Joules / 28 Joules

External: Connection to external resistor, 33Ω min, 15Arms, 2kW

EP216: 20Ω, 20Arms, 5kW

### Drive Control Inputs

Analog: (1) +/-10Vdc, 14 bit, 100 kOhm, differential

Analog max. input rating: differential +/-14Vdc, each input with reference to analog ground +/-14Vdc

Digital: (16) (5 on EP-B) +10 to 30Vdc, 4.8kΩ, sourcing, optically isolated

Pulse: (1) Differential RS-422, 1 MHz/channel, 50% duty cycle

Single-ended: (1) TTL Schmitt trigger 500kHz/channel, 50% duty cycle

Motor overtemperature: 0 to +5Vdc, 1 kΩ, single-ended

### Drive Control Outputs

Analog: (2) +/-10Vdc, 10 bit, single-ended 20mA

Digital: (8) (3 on EP-B) +10 to 30Vdc, 150mA, sourcing optically isolated

Pulse: Differential RS-422 and TTL compatible, 20mA/channel sink or source

### Environmental

Rated ambient temperature: 32 to 104 °F (0 to 40 °C) for rated performance

Maximum ambient temperature: 32 to 122 °F (0 - 50°C) with power derating of 3.0%/ 1 °C above 40 °C

Rated altitude: 1000m

Maximum altitude: For altitudes > 1000m derate output by 1%/100m

Vibration: 10 to 2000Hz @ 2g

Humidity: 10 to 95% non-condensing

Storage temperature: -13 to 167 °F (-25 to 75 °C)

Ingress protection: IP-20

### Serial Interface

2 RS-485 connectors for multi-drop applications Modbus RTU w/ 32-bit extension, 9600 to 19.2kbaud

### Ethernet Interface (EP-P only)

1 RJ-45, Modbus TCP/IP or EtherNet/IP @ 10/100M bandwidth

### DeviceNet (EP-xDN models only)

Power consumption: 25mA  
 Baud rates: 125, 250 and 500kps  
 Node addresses: 00-63

### Profibus-DP (EP-PPB model only)

Baud: 1.5 to 12Mb  
 Address Range: 00 to 126

## Dimensions

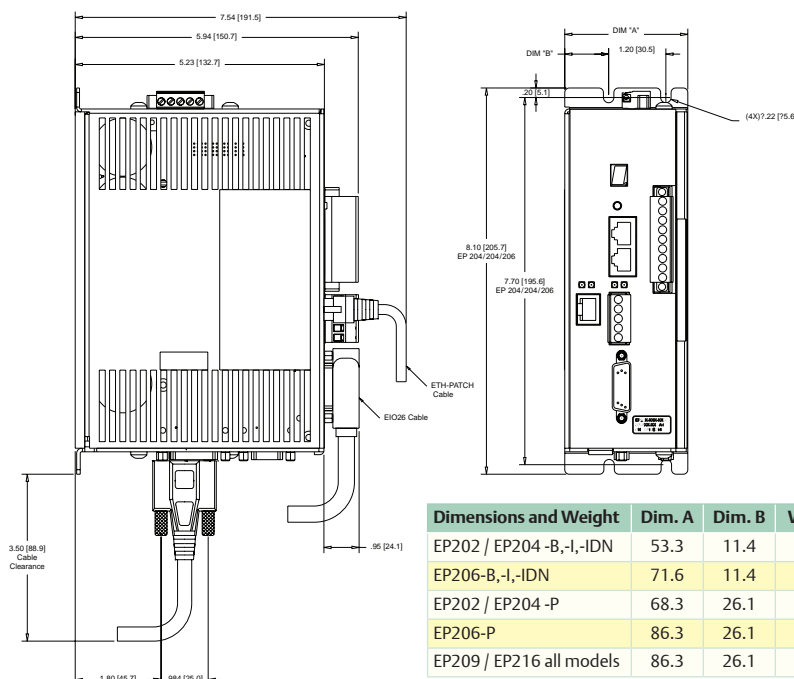

Dimensions and Weight	Dim. A	Dim. B	Weight (kg)
EP202 / EP204 -B,-I,-IDN	53.3	11.4	1.63
EP206-B,-I,-IDN	71.6	11.4	1.91
EP202 / EP204 -P	68.3	26.1	1.77
EP206-P	86.3	26.1	2.04
EP209 / EP216 all models	86.3	26.1	2.49

## Epsilon EP Order String

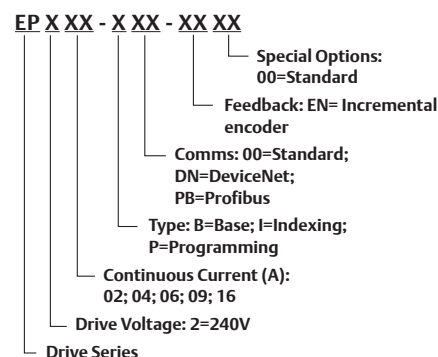

# Driving Technology...



## AMERICAS

Toll-free: 1-800-893-2321  
info.cta@emerson.com

Minneapolis Drive Center  
Headquarters  
T: 952 995 8000

Calgary Drive Center  
T: 403 253 8738

Charlotte Application Center  
T: 704 424 9811

Cleveland Drive Center  
T: 216 901 2400

Grand Island  
Americas Service Center  
T: 716 774 1193

Los Angeles Application Center  
T: 562 943 0300

Portland Drive Center  
T: 503 266 2094

Providence Application Center  
T: 401 392 4256

Toronto Application Center  
T: 905 948 3402

## LATIN AMERICAN & CARIBBEAN REGION

Miami Sales Office  
T: 305 818 8897

*For current authorized distributors or resellers, please check the Control Techniques web site.  
www.controltechniques.com*

## BRAZIL

São Paulo Application Center  
T: +55 11 3618 6688  
controltechniques.br@emerson.com

## AUSTRALIA

Melbourne  
Application Center  
T: +613 973 81777  
controltechniques.au@emerson.com

Sydney Drive Center  
T: +61 2 9838 7222  
controltechniques.au@emerson.com

## AUSTRIA

Linz Drive Center  
T: +43 7229 789480  
controltechniques.at@emerson.com

## BELGIUM

Brussels Drive Center  
T: +32 1574 0700  
controltechniques.be@emerson.com

## CHINA

Shanghai Drive Center  
T: +86 21 5426 0668  
controltechniques.cn@emerson.com

Beijing Application Center  
T: +86 10 856 31122 ext 820  
controltechniques.cn@emerson.com

## CZECH REPUBLIC

Brno Drive Center  
T: +420 511 180111  
controltechniques.cz@emerson.com

## DENMARK

Copenhagen Drive Center  
T: +45 4369 6100  
controltechniques.dk@emerson.com

## FRANCE\*

Angoulême Drive Center  
T: +33 5 4564 5454  
controltechniques.fr@emerson.com

## GERMANY

Bonn Drive Center  
T: +49 2242 8770  
controltechniques.de@emerson.com

Chemnitz Drive Center

T: +49 3722 52030  
controltechniques.de@emerson.com

Darmstadt Drive Center

T: +49 6251 17700  
controltechniques.de@emerson.com

## GREECE\*

Athens Application Center  
T: +0030 210 57 86086/088  
controltechniques.gr@emerson.com

## HOLLAND

Rotterdam Drive Center  
T: +31 184 420555  
controltechniques.nl@emerson.com

## HONG KONG

Hong Kong Application Center  
T: +852 2979 5271  
controltechniques.hk@emerson.com

## INDIA

Chennai Drive Center  
T: +91 44 2496 1123/  
2496 1130/2496 1083  
controltechniques.in@emerson.com

Pune Application Center  
T: +91 20 2612 7956/2612 8415  
controltechniques.in@emerson.com

New Delhi Application Center  
T: +91 112 2581 3166  
controltechniques.in@emerson.com

## IRELAND

Newbridge Drive Center  
T: +353 45 448200  
controltechniques.ie@emerson.com

## ITALY

Milan Drive Center  
T: +39 02575 751  
controltechniques.it@emerson.com

Reggio Emilia Application Center  
T: +39 02575 751  
controltechniques.it@emerson.com

Vicenza Drive Center  
T: +39 0444 933400  
controltechniques.it@emerson.com

## SOUTH KOREA

Seoul Application Center  
T: +82 2 3483 1605  
controltechniques.kr@emerson.com

● Drive and Application Centers  
● International Distribution Depots

Control Techniques has a network of over 500 distributors in North America. Call for the distributor nearest you.

## MALAYSIA

Kuala Lumpur Drive Center  
T: +603 5634 9776  
controltechniques.my@emerson.com

## REPUBLIC OF SOUTH AFRICA

Johannesburg Drive Center  
T: +27 11 462 1740  
controltechniques.za@emerson.com

Cape Town Application Center  
T: +27 21 556 0245  
controltechniques.za@emerson.com

## RUSSIA

Moscow Application Center  
T: +7 495 981 9811  
controltechniques.ru@emerson.com

## SINGAPORE

Singapore Drive Center  
T: +65 6891 7600  
controltechniques.sg@emerson.com

## SLOVAKIA

Emerson A.5  
T: +421 32 7700 369  
controltechniques.sk@emerson.com

## SPAIN

Barcelona Drive Center  
T: +34 93 680 1661  
controltechniques.es@emerson.com

Bilbao Application Center  
T: +34 94 620 3646  
controltechniques.es@emerson.com

Valencia Drive Center  
T: +34 96 154 2900  
controltechniques.es@emerson.com

## SWEDEN\*

Stockholm Application Center  
T: +468 554 241 00  
controltechniques.se@emerson.com

## SWITZERLAND

Lausanne Application Center  
T: +41 21 637 7070  
controltechniques.ch@emerson.com

Zurich Drive Center

T: +41 56 201 4242  
controltechniques.ch@emerson.com

## TAIWAN

Taipei Application Center  
T: +886 2 8161 7695  
controltechniques.tw@emerson.com

## THAILAND

Bangkok Drive Center  
T: +66 2962 2092 99  
controltechniques.th@emerson.com

## TURKEY

Istanbul Drive Center  
T: +90 216 4182420  
controltechniques.tr@emerson.com

## UAE\*

Emerson FZE  
T: +971 4 8118100  
ct.dubai@emerson.com

## UNITED KINGDOM

Telford Drive Center  
T: +44 1952 213700  
controltechniques.uk@emerson.com

\* Operated by sister company, Leroy Somer®

