

*Advanced Linear and Rotary Actuators  
with Embedded Electronics*

## **Tritex II™ AC or DC Powered Actuators**

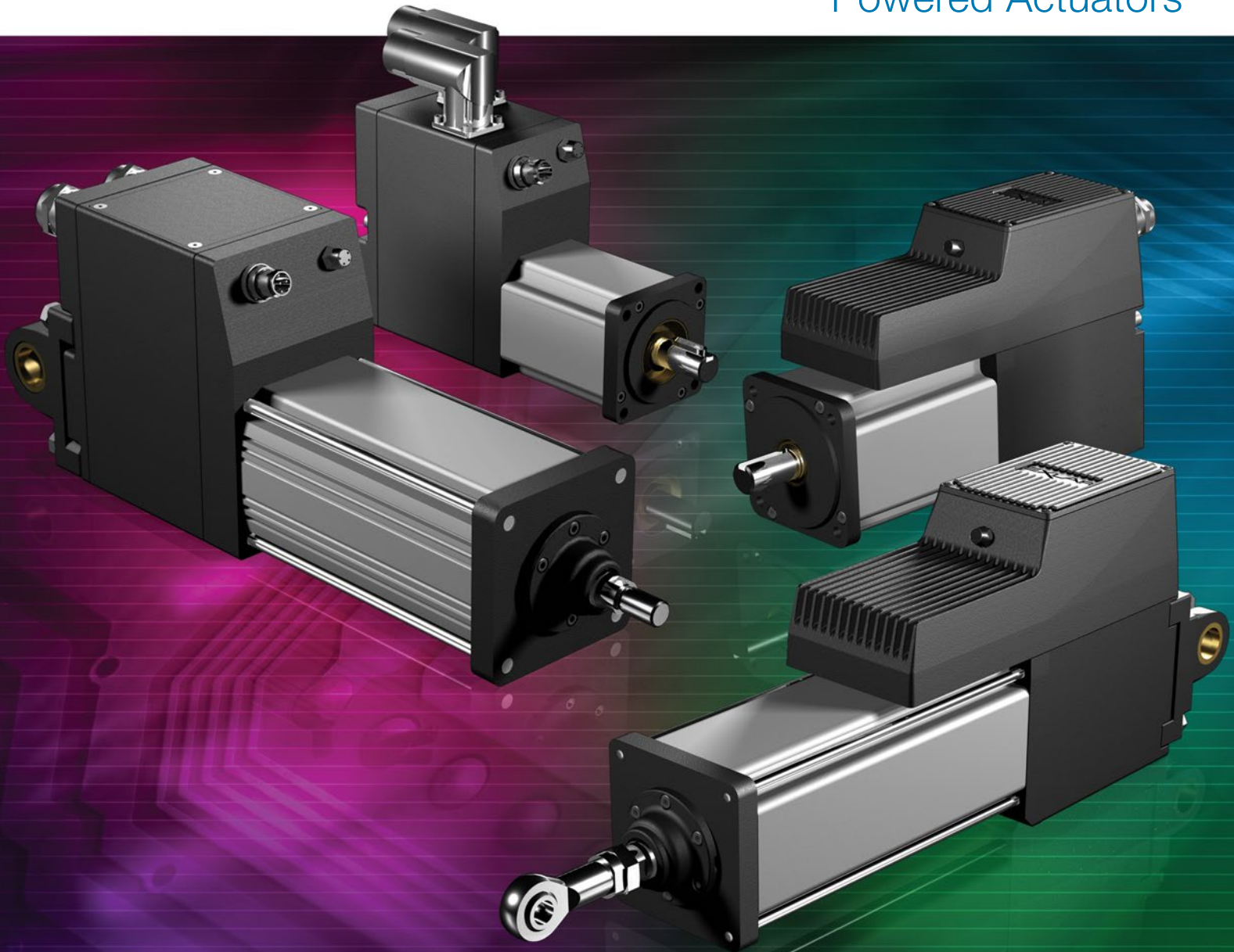

**EXLAR**  
a Curtiss-Wright Company

# Industry's Most Compact All-In-One Linear & Rotary Motion Actuators

By combining the latest electronic power technology with advanced thermal management modeling technology, Exlar has set a new benchmark for electric actuator performance versus size. The Tritex II actuators now integrate an AC or DC powered servo drive, digital position controller, brushless motor and linear or rotary actuator in one elegant, compact, sealed package. Now you can distribute motion control and solve your application with one integrated device. Simply connect power, I/O, communications and go!



Linear Tritex II DC Actuator

Linear Tritex II AC Actuator

TRITEX

## Tritex II System

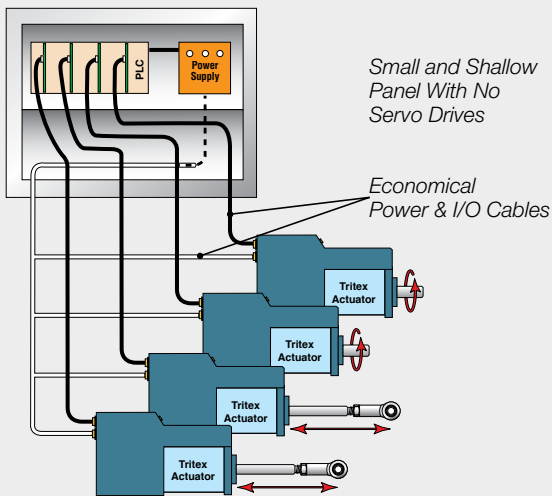

## Alternative Systems

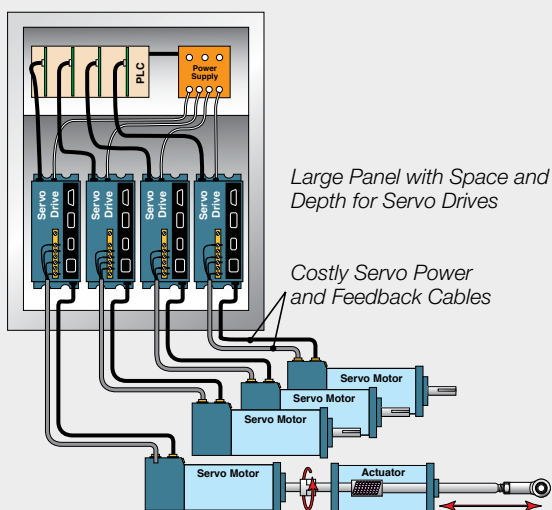

## Dramatically Reduce Space Requirements

Tritex II actuators are the highest power density, smallest footprint servo drive devices on the market. Finally, you can incorporate a fully electronic solution in the space of your existing hydraulic or pneumatic cylinder. You can also eliminate troublesome ball screw actuators or bulky servo gear reducers. And the space previously consumed by panel mount servo drives and motion controllers is no longer needed. Tritex II actuators may also reduce the size of your machine design while offering significant reliability improvement.

## Reduce Costs

You eliminate the labor costs for mounting and wiring the panels because the Tritex II houses the servo drive, digital positioner, and actuator all in one convenient package. Cable costs are also significantly reduced by eliminating the need for expensive, high-maintenance specialty servo cables. All that is required is an economical standard AC or DC power cord, and standard communication cable for digital and analog I/O.

Also eliminated are the issues associated with power signals and feedback signals traveling long distances from servo drive to servo motor. With the Tritex II, the servo drive and motor are always integrated in the same housing.

## No Compromise on Power, Performance or Reliability

Tritex II actuators offer a benefit that no other integrated product offers – POWER! No longer are you limited to trivial amounts of force, or speeds so slow that many motion applications are not possible.

### Tritex II AC Actuator

- Continuous force to 3225 lbf (14kN)
- Peak force to 5400 lbf (24kN)
- Speed to 33 in/sec (800 mm/sec)
- 1.5 kW servo amplifier
- Temperature operation range -40°C to +65°C
- AC Power 100V – 240V, +/-10%

### Tritex II DC Actuator

- Continuous force to 872 lbf (4kN)
- Peak force to 1190 lbf (5kN)
- Speed to 33 in/sec (800 mm/sec)
- 750W servo amplifier
- Temperature operation range -40°C to +65°C
- DC Power 12-48 VDC nominal



# Applications

## Linear Applications

Tritex II linear actuators employ Exlar's patented inverted roller screw mechanism for converting rotary motion to highly robust and long-life linear motion. These characteristics enable the Tritex actuator to solve applications that previously required pneumatic or hydraulic cylinders. No additional mechanisms (such as acme or ball screws) are necessary to convert the actuator's rotary power into linear motion in order to move the load.

Ideal for mobile and remote applications using DC power sources, the Tritex II DC actuators offer the power needed to perform real world applications. The simple to configure, yet powerful interface software allows either the AC or DC Tritex II actuators to perform nearly any motion application. The Tritex II linear actuator can be programmed to follow an analog command signal, making it ideal for controlling valves and dampers in process control applications or adjustment mechanisms on mobile equipment.

## Longer Stroke Length Considerations

If your application requires a stroke length greater than the 18 inches available with Tritex II linear units, consider mounting a rotary Tritex II actuator to one of Exlar's universal actuators. This combination will allow stroke length up to 40 inches. Please contact Exlar for more details.

## Rotary Applications

Tritex II rotary motors and gearmotors provide high response and precise control of a rotatable shaft similar to that found in any electric motor. The difference is that with Tritex II you can program (via your PC) the rotational speed and position of the output shaft in

response to external commands. For example, the motor can be commanded to rotate at a controlled velocity and precisely stop at a preprogrammed position. You can also program the unit to run at a preset velocity until a switch input is received or a preprogrammed torque level is produced against a load. Alternatively, the rotary Tritex II actuators can be set up to follow an analog signal, either voltage or current, representing your choice of torque, velocity, or position.

Signals for initiating the preprogrammed velocity and position commands come from optically isolated inputs or directly via network communications. Likewise, isolated output commands of the status and events allow precise coordination with your system controls or machine operator.

## Flexible Communications

Multiple feedback types, including absolute feedback, allow you to select the system that is best-suited for your application. Digital and analog I/O, plus popular communication networks such as Modbus TCP, Ethernet/IP, PROFINET IO and CANopen allow the Tritex II to become an integral part of your control architecture or machine control processes.

## Optional Internal Gear Reducer

If the application requires greater torque and less speed than available with the base unit, the Tritex II is available with an integral servo grade planetary gear reducer. Gear ratios of 4:1 to 100:1 allow the power of Tritex II to be applied over a broad range of torque requirements.

*Rotary Tritex II Actuator*

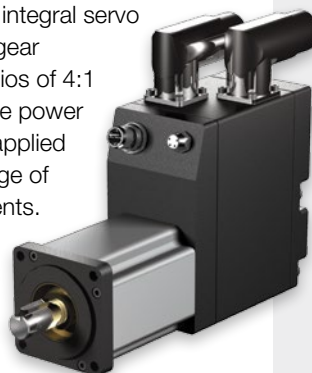

## Roller Screw Basics

Exlar's inverted roller screw is a mechanism for converting rotary torque into linear motion, in a similar manner to acme screws or ball screws. But, unlike those devices, roller screws can carry heavy loads for thousands of hours in the most arduous conditions. This makes roller screws the ideal choice for demanding, continuous-duty linear motion applications. The difference is in the roller screw's design for transmitting forces. Multiple threaded helical rollers are assembled in a planetary arrangement around a threaded shaft as seen below, which converts a motor's rotary motion into linear movement of the shaft or nut.

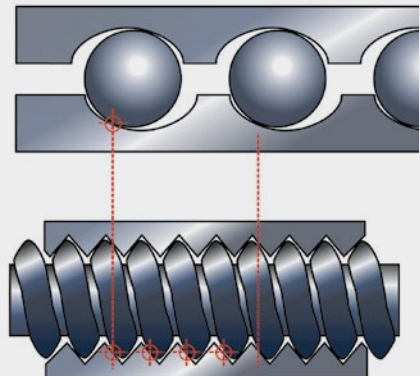

*Compare a similar size ball screw to Exlar's planetary roller screw design and see many more contact points on the roller screw. This results in higher load-carrying capacity and improved stiffness.*

# The Exlar Advantage

## Standard Ratings for Exlar Actuators

The standard IP rating for Exlar Actuators is IP54S or IP65S. Ingress protection is divided into two categories; solids and liquids.

For example, in IP65 the three digits following "IP" represent different forms of environmental influence:

- The first digit represents protection against ingress of solid objects.
- The second digit represents protection against ingress of liquids.
- The suffix digit represents conditions of motion during the test.

### Digit 1 - Ingress of Solid Objects

The IP rating system provides for 6 levels of protection against solids.

1	Protected against solid objects over 50 mm e.g. hands, large tools.
2	Protected against solid objects over 12.5 mm e.g. fingers.
3	Protected against solid objects over 2.5 mm e.g. wire, small tools.
4	Protected against solid objects over 1.0 mm e.g. wires.
5	Limited protection against dust ingress. (no harmful deposit)
6	Totally protected against dust ingress.

### Digit 2 - Ingress of Liquids

The IP rating system provides for 9 levels of protection against liquids.

1	Protected against vertically falling drops of water or condensation.
2	Protected against falling drops of water, if the case is disposed up to 15 degrees from vertical.
3	Protected against sprays of water from any direction, even if the case is disposed up to 60 degrees from vertical.
4	Protected against splash water from any direction.
5	Protected against low pressure water jets from any direction. Limited ingress permitted.
6	Protected against high pressure water jets from any direction. Limited ingress permitted.
7	Protected against short periods of immersion in water of 1m or less for 30 minutes or less.
8	Protected against long, durable periods of immersion in water.
9	High-pressure, high-temperature wash-down applications.

### Suffix

S	Device standing still during test	M	Device moving during test
---	-----------------------------------	---	---------------------------

## Tritex II Models

### Tritex II AC Models

- T2M standard mechanical capacity actuator, 75, 90 and 115 mm
- T2X high mechanical capacity actuator, 75, 90 and 115 mm
- R2M rotary motor, 75, 90 and 115 mm
- R2G rotary gearmotor, 75, 90 and 115 mm

### Tritex II DC Models

- TDM standard mechanical capacity actuator, 60 and 75 mm
- TDX high mechanical capacity actuator, 60 and 75 mm
- RDM rotary motor, 60, 75 and 90 mm
- RDG rotary gearmotor, 60, 75 and 90 mm

## Feedback Types (All Models)

- Analog Hall w/1000 count resolution
- Incremental encoder with 8192 count resolution
- Absolute Feedback (analog hall with multi-turn, battery backup)

## Communications & I/O

The I/O count and type varies with each actuator model and option selected. Please see page 11 for Tritex II AC and page 33 for Tritex II DC models.

## Standard Communications (All Models):

- 1 RS485 port, Modbus RTU, opto-isolated for programming, controlling and monitoring



*Tritex II rotary motor with connectors shown left and Tritex II linear actuator with customer-supplied cable glands ports shown above.*

## Typical Applications

- Process Control
- Testing
- Simulation
- Industrial Automation
- Semi-conductor
- Autonomous Vehicles
- Medical Equipment
- Automotive Assembly
- Molding
- Die Casting
- Welding
- Dampers
- Valve Actuation



## Tritex II Series Operation

The Tritex II Series actuators can operate in one of five different motion-producing modes. These modes solve an endless variety of applications in industrial automation, medical equipment, fastening and joining, blow molding, injection molding, testing, food processing, and more.

Programmed functions are stored in the Tritex II non-volatile memory. A standard RS485 serial interface allows control, programming and monitoring of all aspects of the motor or actuator as it performs your application. Optional communications protocols are available.

## Tritex Option Boards

- Option boards offer additional functionality to the base Tritex II actuators
  - Terminal board for customer I/O
  - Isolated 4-20mA analog input and output
  - Customer specific
- Communication buses
  - EtherNet/IP
  - Modbus TCP
  - PROFINET IO
  - CANopen

## Connectivity

- Internal terminals accessible through removable cover (select models)
- Threaded ports for cable glands (select models)
- Optional connectors
  - M23 Power - M23/M16 I/O
- M8 connector for RS485
- M12 connector for EtherNet options
- Custom connection options
- Embedded leads (select models)

## Selectable Input Functions

- Enable
- Execute Move (0-15)
- Dedicated Position
- Jog+
- Jog-
- Jog Fast
- Home
- Extend Switch
- Retract Switch
- Home Switch
- Teach Enable
- Teach Move (1-16)
- Select Move
- Stop
- Hold
- Alternate Mode; allows you to switch between 2 operating modes.
- Reset Faults

## Selectable Output Functions

- Enabled
- Homed
- Ready (Enabled and Homed)
- Fault
- Warning
- Fault or Warning Active
- Move (0-15) in Progress
- Homing
- Jogging
- Jogging+
- Jogging-
- Motion
- In Position
- At Home Position
- At Move (0-15) Position
- Stopped
- Holding
- In Current Limit
- In Current Fold back
- Above Rated Current
- Home

## Operating Modes

### 1) Move to a position (or switch)

The Tritex II Series actuators allow you to execute up to 16 programmed positions or distances. You may also use a limit switch or other input device as the end condition of a move. This combination of index flexibility provides a simple solution for point-to-point indexing.

### 2) Move to a preset force or torque

The Tritex II Series allows you to terminate your move upon the achievement of a programmed torque or force. This is an ideal mode for pressing and clamping applications.

### 3) Position proportional to an analog signal

Ideal for process control solutions, the Tritex II Series provides the functionality to position a control valve

by following an analog input signal.

This allows the Tritex II Series to deliver precise valve control — control that cannot be achieved by other electric, hydraulic or pneumatic actuators.

### 4) Velocity proportional to an analog signal

Tritex II actuators offer you the capability to control velocity with an analog signal. This is particularly useful with Tritex II rotary motors offering precise control of the speed of any process or operation.

### 5) Force/torque proportional to analog signal

Perfect for pressing and torquing applications, you can control torque from an analog input while in torque mode.

# Expert User Interface

Expert, the Tritex II user interface software, provides you with a simple way to select all aspects of configuration and control required to set up and operate a Tritex II actuator. Easy-to-use tabbed pages provide access to input all of the parameters necessary to successfully configure your motion application. 'Application' files give you a convenient way to store and redistribute configurations amongst multiple computers, and 'Drive' files allow the same configuration to be distributed to multiple Tritex II actuators. Motion setup, homing, teach mode, tuning parameters, jogging, I/O configuration, and local control are all accomplished with ease using Expert software.

## Protocol Options

The standard communication protocol for Tritex is an RS485 connection using Modbus RTU. The Modbus protocol provides a simple and robust method to connect industrial electronic devices on the same network. The Expert software acts as a Modbus Master and the Tritex II acts as the Slave device, only responding to requests commanded from the software. The Expert software allows full access to commissioning, configuring, monitoring and controlling the Tritex II.

In addition to Modbus RTU communications, the following protocol options are available by selecting communication option boards. Exlar requires initial commissioning of a Tritex II actuator to be performed with the Modbus protocol.

### Modbus TCP

Modbus TCP couples Modbus communication structure from Modbus RTU with EtherNet connectivity. The Modbus TCP option is fully supported by the Expert software and offers seamless use for

commissioning, configuring, monitoring and controlling the Tritex II. A Modbus mapping table allows you to map all of the parameters you wish to read and modify into a register bank of up to 100 registers. This will allow a PLC program to perform a single read operation and a single write operation to all the parameters.

### EtherNet/IP

EtherNet/IP allows you to change, monitor and control the Tritex II through implicit or explicit messaging initiated from your Rockwell PLC. Tritex parameters are set up through the Expert software using a Tritex II parameter to EtherNet/IP parameter mapping table. Up to 100 input and 100 output 16 bit registers can be mapped to Tritex II parameters.

### PROFINET IO

PROFINET IO allows you to change, monitor and control the Tritex II from your Siemens PLC. Tritex parameters are set up through the Expert software using a Tritex II parameter to PROFINET IO parameter mapping table. Up to 100 input and 100 output 16 bit registers can be mapped to Tritex II parameters.

### CANopen

The Tritex II with the CANopen network is intended to perform as a Slave receiving commands from a CANopen Master. It does not have all the features of a standalone indexer, like other Tritex models. CANopen Communication protocol DSP301 is supported as well as DSP 402 supporting Profile Torque, Profile Velocity, Profile Position and Homing. Setup on the system is most easily achieved with the Expert software using the RS485 port.

## Modbus Mapping Screen

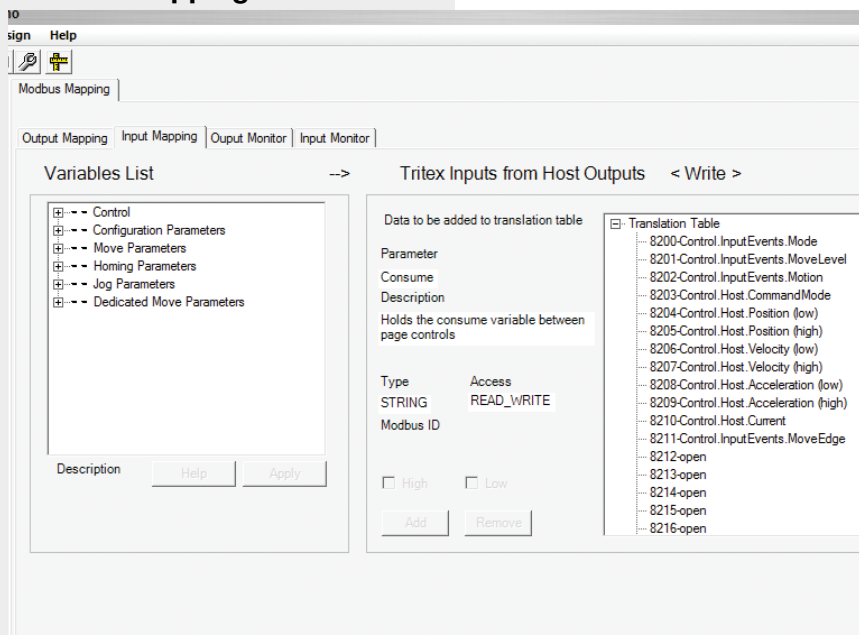

## Motion Setup

Exlar configuration provides several templates for various applications. These can serve as your configuration, or as a starting point for your configuration. You can also begin by selecting configuration details specific to your application. You can configure a move to position, move to switch, or move to force motion at the click of a button. The Tritex II products offer absolute and incremental motion, as well as moves ending on a condition such as a specific force or torque.

## Control Page

The Expert control page gives you the ability to initiate all motion functions from one simple screen. This screen provides you with very easy system start-up and testing without all the inconvenience of machine wiring.

The control page offers the capability to enable and disable the drive and perform fast and slow jogs. This gives you the ability to verify motion before needing any I/O wiring.

## Monitoring and Diagnostics

All input functions can be monitored and activated from the Expert monitor page, and all output functions can be monitored. Information on critical fault and status data is available as a separate page, or as a fixed window on the bottom of each page of the software.

## Configuring I/O

A pull down menu allows all I/O to be set up in minutes. Inputs can be configured to be maintained, or momentary, depending on the application requirements. Input and output logic can also be inverted with a simple click.

## Homing

You can home to an input, by using a proximity or limit switch, or home to a specific force or torque.

Homing to a force or torque is ideal for setting up applications that require motion referenced to a hard stop, like the closed position of a valve, or the final position of a press.

## Teach Mode

In this mode, you can jog the actuator to the desired position, and activate an input, or click a button in the Expert software and the current position of the actuator becomes the defined distance or absolute position associated with a particular move command.

## Scope

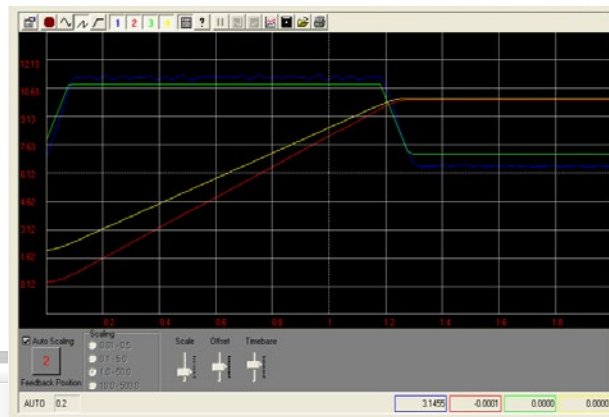

## EtherNet IP Mapping Screen

## Scope

The Expert Software includes a four channel digital oscilloscope feature.

The user can select up to four Tritex drive parameters to be monitored simultaneously.

For high speed requirements the data can be captured in the drive's memory at an adjustable rate down to 100 micro seconds, then uploaded for plotting. The plots can be saved or printed and the captured data can be saved as a comma separated file for further analysis with Excel.



# Process Control Functionality

Precise valve and damper control is the perfect application for Tritex II actuators. They outperform other electric, hydraulic and pneumatic actuators by providing small hysteresis and dead band, quick response to small signal changes and stable dynamic responses.

Fully programmable to follow an analog or digital signal representing either position or force, the Tritex II linear actuator is perfectly designed for control valve applications with thrust requirements up to 3225 lbf or rotary torque applications up to 95 lbf-in continuous.

The Tritex II Rotary actuators are ideal for directly operating quarter-turn valves. Gear ratios of 4:1 to 100:1 allow the power of Tritex II to be applied to a broad range of applications, providing high turndown without loss of accuracy.

Tritex II actuators can be mounted on any valve from any manufacturer.

## Valve Software

Our valve software is simple to use, featuring a teach mode for foolproof stroke configuration. Included is a programmable valve cut off position feature that enables a firm valve seat on either new valves, or retrofitted valves. Several diagnostics and auxiliary I/O options are also available.

## Class I Division 2 Rating

Exlar's Tritex II actuators are available for applications requiring CSA Class I Division 2 certification. Ordering a standard I/O interconnect with or without 4-20 mA Analog I/O, and the N option for the NPT port will provide you with Class I Division 2 rated product.

## Benefits for Process Control Applications

### Extreme Accuracy

The Exlar actuators stroke the valve based on position, not air or oil pressure. Accuracy and repeatability are better than 0.1%.

### 100% Duty Cycle

Exlar's unique way of converting rotary motor motion to a linear force using a roller screw provides full modulation capability. Life is measured in 100's of million strokes vs. thousands like typical electric actuators.

### Built in Positioner

The Tritex II actuators from Exlar include a built in positioner with a 4-20 mA or digital signal to tell you the exact stroke position. An analog output is also available.

### Flexibility

The Tritex II actuators include digital I/O in addition to analog control. This provides the user with options for additional control such as emergency stop, +/- jog or various diagnostic conditions.

### Low Power Consumption

The Tritex II actuator only uses the current needed for a given force. This extreme efficiency makes it suitable for use with solar panels and batteries.

### Fast Response and Stroke Speeds

Most other electric actuators are known for being slow — a major disadvantage.

Tritex II response rate is measured in milliseconds. Stroke speeds can be up to 33 in/sec.

### Hydraulic Replacement

Tritex actuators have the same capabilities as a hydraulic equivalent, but without the cost or maintenance issues. High force, fast speeds and precise movements make it a suitable substitute for hydraulic applications.

### Absolute Feedback

The absolute feedback option gives the actuator memory after teaching the valve limits. Upon power loss, the battery backup will maintain the valve limits.

### Manual Override

Two optional are available. The hand wheel option gives you a manual engagement switch that can be used to disable the power to the actuator. The side drive option allows for emergency operation in a power down condition using a standard socket wrench.

### Diagnostics

All inputs and outputs can be monitored including position, temperature, current and many more. An oscilloscope feature is also included, allowing a user to select up to four parameters to be monitored simultaneously. The data can be captured in the drive's memory at an adjustable rate down to 100 micro sec, and then uploaded for plotting.

The screenshot displays the Tritex II valve software interface, which is divided into several functional areas:

- Top Panel:** Includes a dropdown menu for "Actuator Direction" set to "Extend to Close".
- Parameters when valve is Closed:** Shows "4.000 mA" and "0.000 REVS".
- Parameters when valve is Open:** Shows "20.000 mA" and "0.000 REVS".
- Velocity / Acceleration:** Shows "Velocity Limit" at "100.0 RPM" and "Acceleration Limit" at "3000 RPM/S".
- Manual Teach Controls:** Features buttons for "Jog to Closed Position", "Teach Closed Position", "Jog to Open Position", and "Teach Open Position". A "Digital (Jog) Mode" button is also present.
- Valve Seating:** Includes a "Travel Cut-off Position" set to "0.00 %", a checkbox for "Enable valve seating at Closed position", and "Seating Limits" for "Seating Velocity" (10.0 RPM), "Peak Seating Current" (2.0 AMPS), and "Foldback Seating Current" (2.0 AMPS).
- Valve Stroke:** A text box explaining that the final valve stroke length is the difference between the Open and Closed Valve Positions, with a note that the Open Valve Position must be greater than the Closed Valve Position.
- Diagnostic and Status Panels:** On the left, there are sections for "Last Fault/Warning" (listing faults like Peak Current, Continuous Current, etc.), "Recent Fault History" (a table of past faults), and "Maximum Stress Values" (showing current, voltage, board temp, and actuator temp).

# Tritex II Agency Approvals



NPT Ports

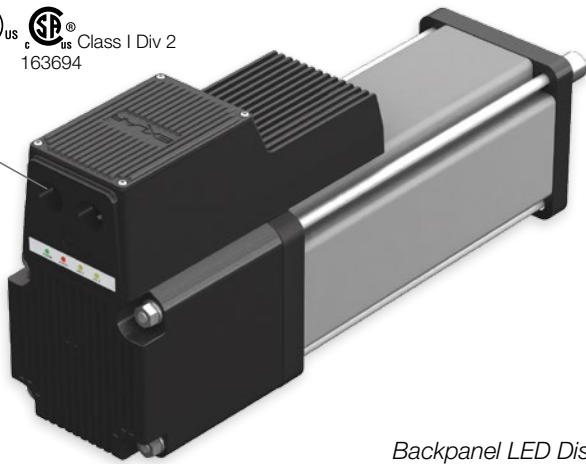

Tritex II linear actuator with threaded ports.

Backpanel LED Display



If your application requires CSA Class I Division 2 Certification please order the “N” connection option for the NPT port. This in combination with one of the following I/O option boards will provide class I Division 2 Certification:

- SIO
- EIN
- TCN
- IA4
- PIN

Shown below are additional agency approvals applied to Tritex II Actuators.

Tritex II AC Standards/Agency Approvals	
Agency/Standard	T2M090 & T2M115 Models/Options
CE, EMC EN61800-3, Safety EN 61800-5-1	All options
CSA 139	All options
CSA Class I, Div 2, Groups A,B,C,D	Requires NPT connection option. Network options, EIN, PIN, TCN and CON
UL 508 C, Type 4 Enclosure	Requires NPT connection option. Network options, EIN, PIN, TCN and CON
IP Rating	Standard IP54S. IP65S available with P5 option.
Vibration Rating	IEC 61800-5-1 safely standard for drives. 1g peak, up to 150 Hz for <2 hrs. IEC 60068-2-64 random vibration standard, 2.5g rms, 50 to 500 Hz.
ODVA	EIP

Consult Exlar for all certifications on the 75 mm AC actuator

Tritex II DC Standards/Agency Approvals	
Agency/Standard	Tritex Models/Options
CE, EMC EN61800-3	All models
CSA 139	All models, when supply voltage is 24 VDC or less
CSA Class I, Div 2, Groups A,B,C,D	75 and 90 mm frames require NPT connection option
IP Rating	Standard IP54S. IP66S available with P5 option
Vibration Rating	IEC 61800-5-1 safely standard for drives. 1g peak, up to 150 Hz for <2 hrs. IEC 60068-2-64 random vibration standard, 5g rms, 50 to 500 Hz.
ODVA	EIP

# Tritex II AC Linear & Rotary Actuators

## No Compromises on Power, Performance or Reliability

With forces to approximately 3,225 lbf (14 kN) continuous and 5,400 lbf peak (24 kN), and speeds to 33 in/sec (800 mm/sec), the AC Tritex II linear actuators also offer a benefit that no other integrated product offers - POWER! No longer are you limited to trivial amounts of force, or speeds so slow that many motion applications are not possible. And the Tritex II with AC power electronics operates with maximum reliability over a broad range of ambient temperatures: -40°C to +65°C. The AC powered Tritex II actuators contain a 1.5 kW servo amplifier and a very capable motion controller. With standard features such as analog following for position, compound moves, move chaining and individual force/torque control for each move, the Tritex II Series is the ideal solution for most motion applications.



Linear Tritex II  
AC Actuator

TRITEX

## Tritex II Models 75, 90 and 115 mm

- T2M standard mechanical capacity actuator
- T2X high mechanical capacity actuator
- R2M rotary motor
- R2G rotary gearmotor

## Power Requirements

- AC Power 100V - 240V, +/- 10%, single phase
- Built-in AC line filter
- Connections for external braking resistor

## Feedback Types

- Analog Hall with 1000 count/motor rev resolution
- Incremental encoder with 8192 count resolution
- Absolute Feedback (analog hall with multi-turn, battery backup)

## Connectivity

- Internal terminals accessible through removable cover
- Threaded ports for cable glands
- Optional connectors
  - M23 Power -M16 I/O (M23 on 75 mm)
- M8 connector for RS485
- M12 connector for Ethernet options
- Custom connection options

NEW 75 mm Tritex II rotary  
integrated actuator.

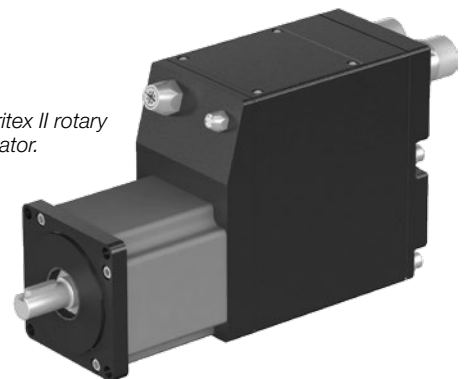



## Communications & I/O

### Digital Inputs:

10 to 30 VDC Opto-isolated

### Digital outputs:

30 VDC maximum

100 mA continuous output

Isolated

### Analog Input AC:

0-10V or +/-10V

0-10V mode, 12 bit resolution

+/-10V mode, 12 bit resolution on

90/115, 13 bit resolution on 75

assignable to Position, Velocity,

Torque or Velocity Override commands.

### Analog Output AC:

0-10V

12 bit resolution on 90/115, 11 bit

resolution on 75

### IA 4 option

4-20 mA input

16 bit resolution

Isolated

Assignable to Position, Velocity or

Torque command

4-20 mA output

12 bit resolution

Assignable to Position, Velocity, Current,

Temperature etc

### Standard Communications:

- 1 RS485 port, Modbus RTU, opto-isolated for programming, controlling and monitoring

The IO count and type vary with actuator model and option module selected.

All models include isolated digital IO, and an isolated RS485 communication port with using Modbus RTU protocol.

### Tritex II AC I/O

	75/90/115 mm frame with SIO, EIP, PIO, TCP	90/115 mm frame with IA4	75 mm frame with IA4	90/115 mm frame with CAN	75 mm frame with CAN
Isolated digital inputs	8	8	4	8	4
Isolated digital outputs	4	4	3	4	3
Analog input, non isolated	1	1	0	0	0
Analog output, non isolated	1	1	0	0	0
Isolated 4-20ma input	0	1	1	0	0
Isolated 4-20ma output	0	1	1	0	0

## Manual Override Options

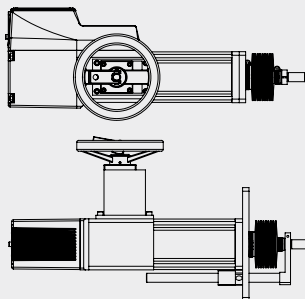

### Handwheel

This option gives you a manual engagement switch that can be used to disable the power to the actuator for manual operation without any external tools.

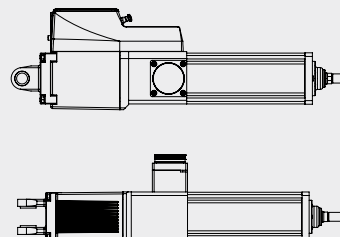

### Side Drive

This option allows for emergency operation in a power down condition using a standard socket wrench.

# Travel Life and Temperature Ratings

## Travel Life

### T2M/T2X Lifetime Curves

The  $L^{10}$  expected life of a roller screw linear actuator is expressed as the linear travel distance that 90% of properly maintained roller screws manufactured are expected to meet or exceed. For higher than 90% reliability, the result should be multiplied by the following factors: 95% x 0.62; 96% x 0.53; 97% x 0.44; 98% x 0.33; 99% x 0.21. This is not a guarantee and these charts should be used for estimation purposes only.

The underlying formula that defines this value is:

Travel life in millions of inches, where:

$$L_{10} = \left(\frac{C}{F}\right)^3 \times S$$

**C** = Dynamic load rating (lbf)

**F** = Cubic mean applied load (lbf)

**S** = Roller screws lead (inches)

*All curves represent properly lubricated and maintained actuators.*

### Dynamic Load Rating

Model	lb (N)	Model	lb (N)
T2M075/090-xx01	3310 (14724)	T2X075/090-xx01	5516 (24536)
T2M075/090-xx02	3570 (15880)	T2X075/090-xx02	5800 (25798)
T2M075/090-xx05	3016 (13416)	T2X075/090-xx05	4900 (21795)
T2M115-xx01	4736 (21067)	T2X115-xx01	7900 (35141)
T2M115-xx02	4890 (21751)	T2X115-xx02	8300 (36920)
T2M115-xx05	4218 (18763)	T2X115-xx05	7030 (31271)
T2M115-xx08	3328 (14804)	T2X115-xx08	6335 (28179)

T2M/X075 and T2M/X090 Estimated  $L_{10}$  Travel Life

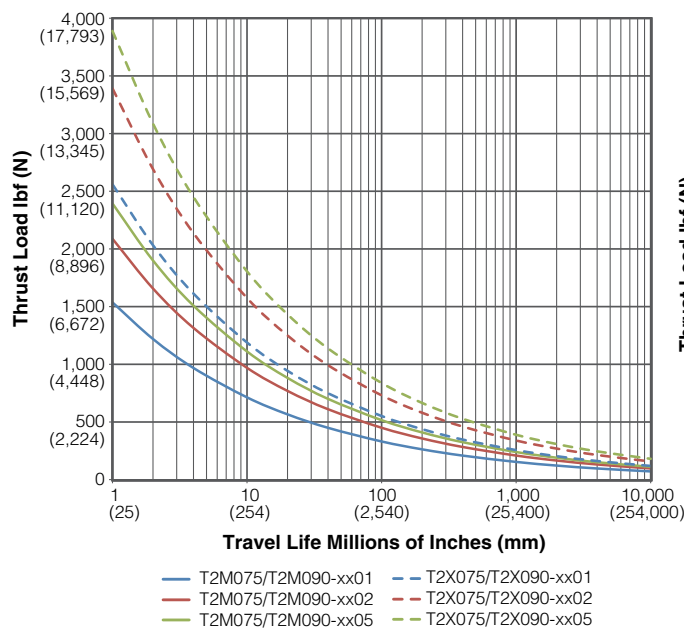

T2M/X115 Estimated  $L_{10}$  Travel Life

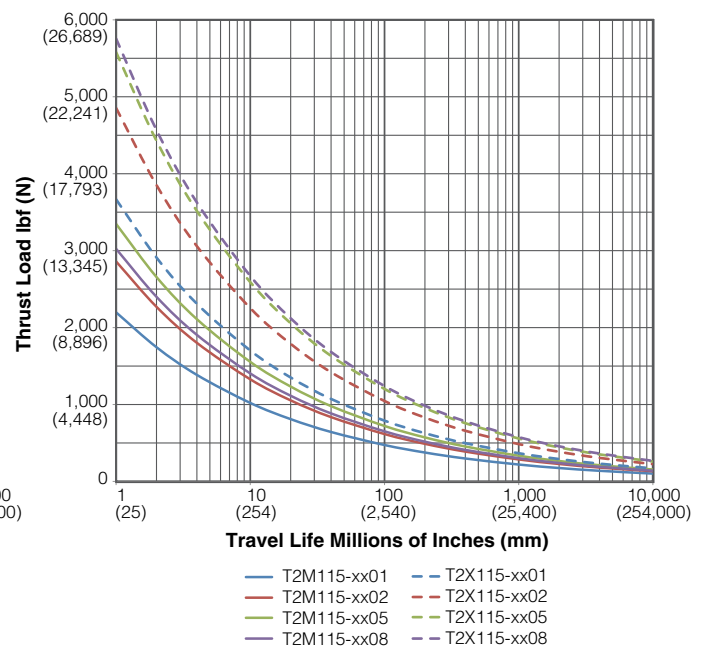

## Extended Temperature De-Rating Curve; 90 and 115 mm

The speed/torque curves are based on 25° C ambient conditions. The actuators may be operated at ambient temperatures up to 65° C. Use the curve shown right for continuous torque/force deratings above 25° C.

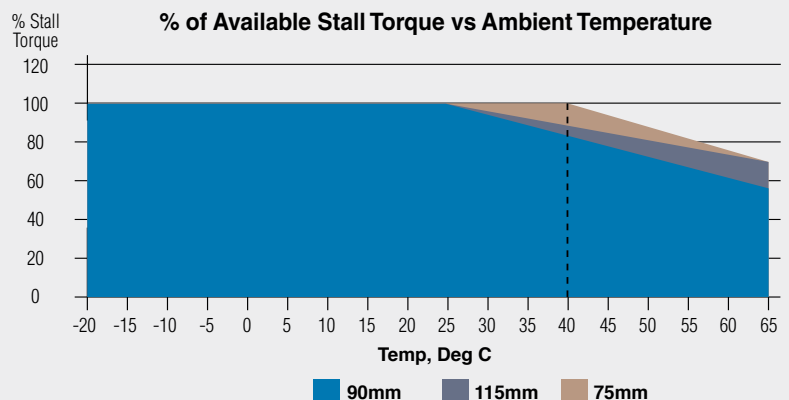

# T2M/X075 Linear Actuator Speed vs. Force Curves

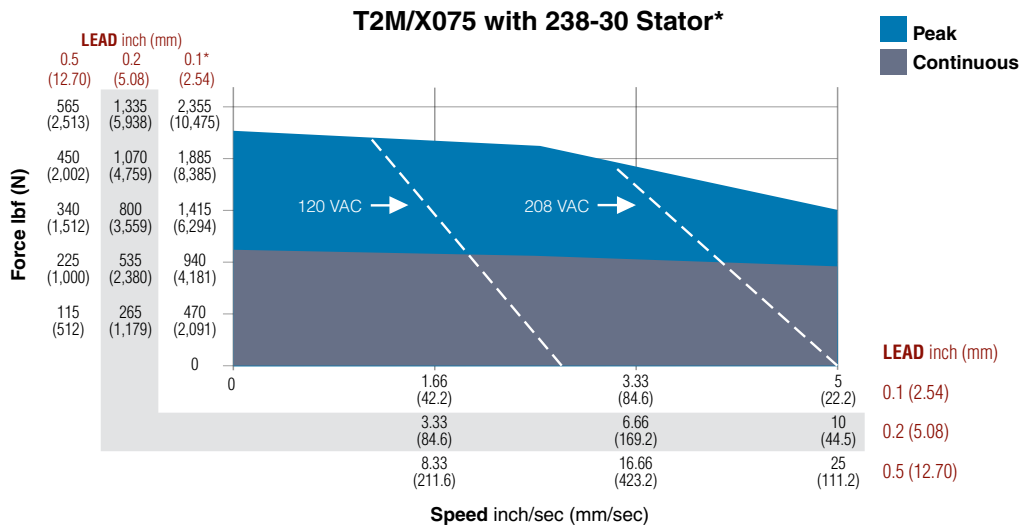
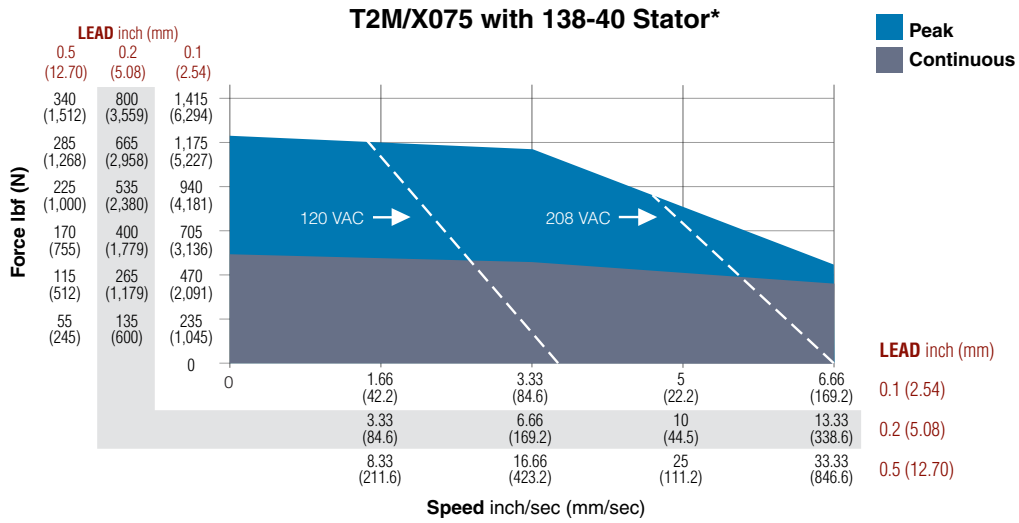

\*T2X peak force for 0.1 inch lead is 2073 lbf (9221 N). T2M peak force for 0.1 inch lead limited to 1620 lbf (7206 N).

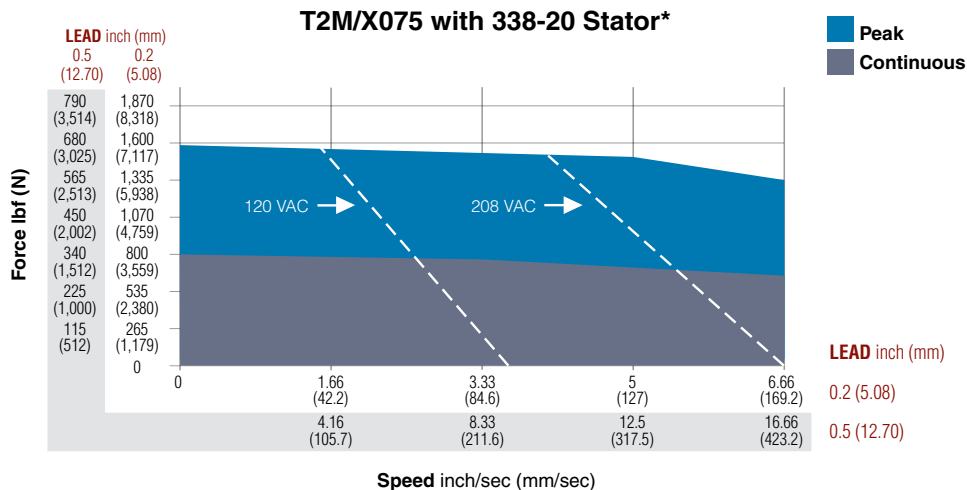

\*Test data derived using NEMA recommended aluminum heatsink 10" x 10" x 3/8".



# T2M/X090 Linear Actuator Speed vs. Force Curves

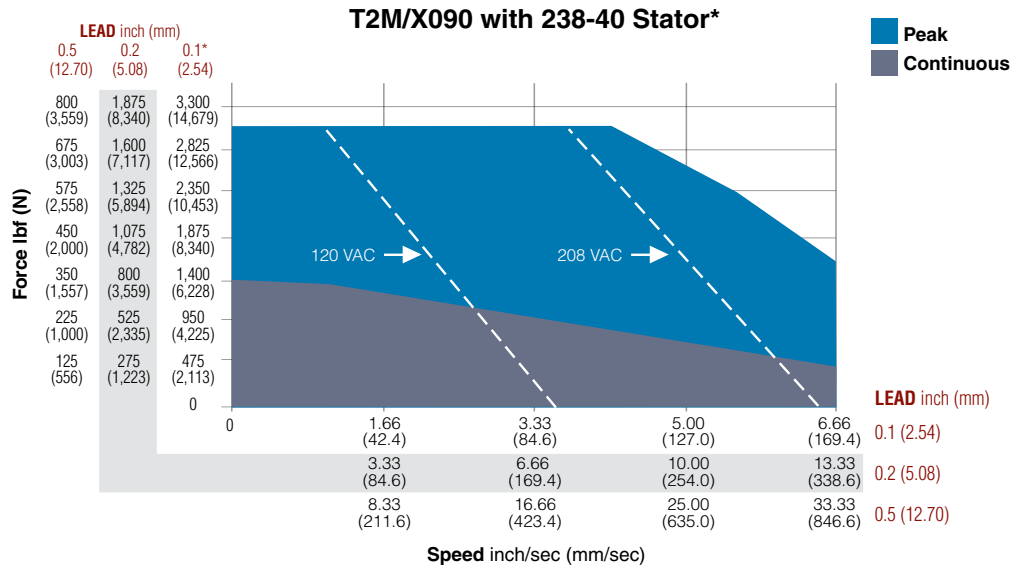
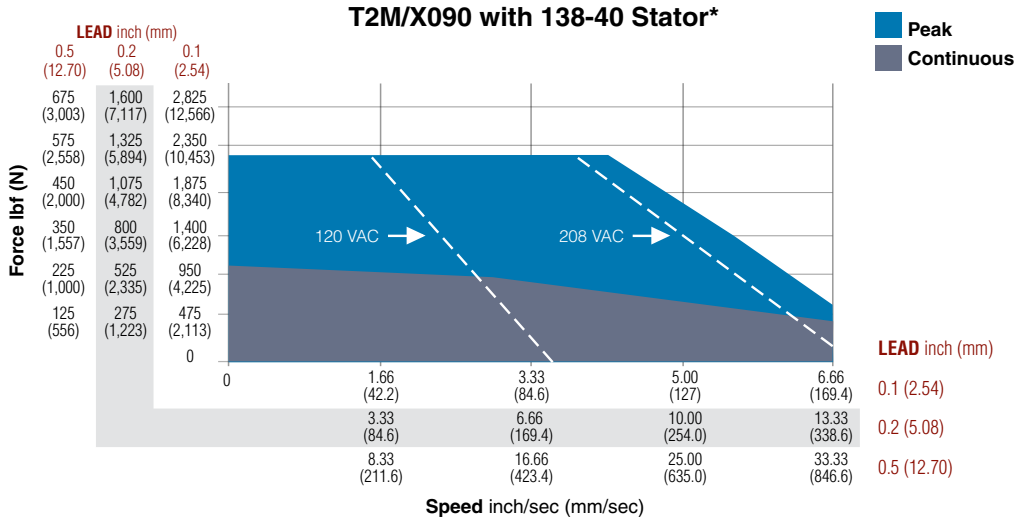

\*T2X peak force for 0.1 inch lead is 2700 lbf (12010 N). T2M peak force for 0.1 inch lead limited to 1620 lbf (7206 N).

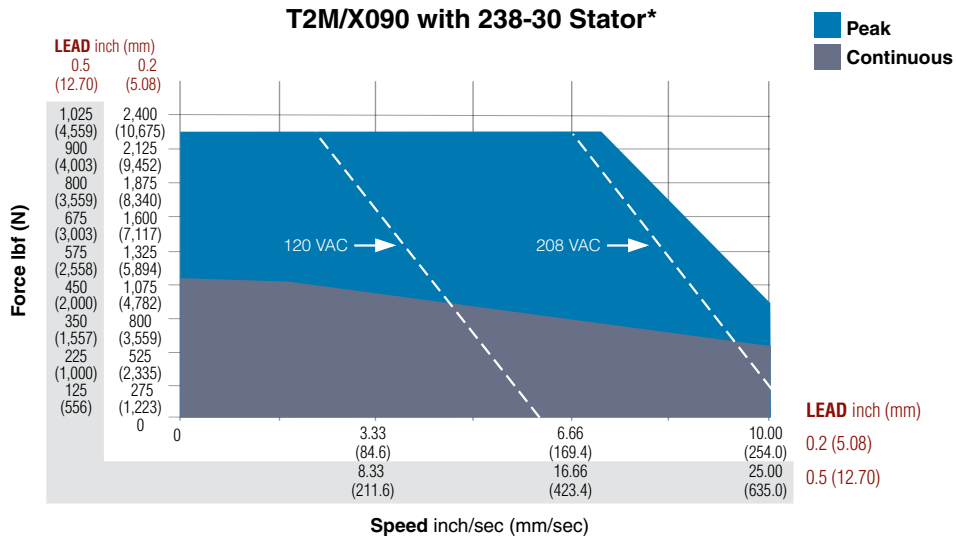

\*Test data derived using NEMA recommended aluminum heatsink 10" x 10" x 3/8".

# T2M/X115 Linear Actuator Speed vs. Force Curves

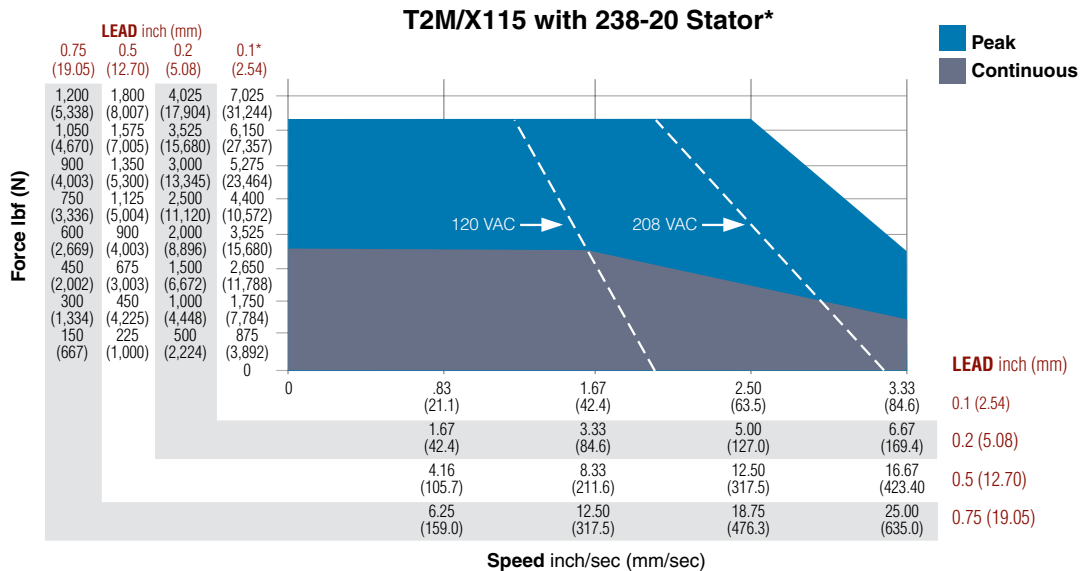
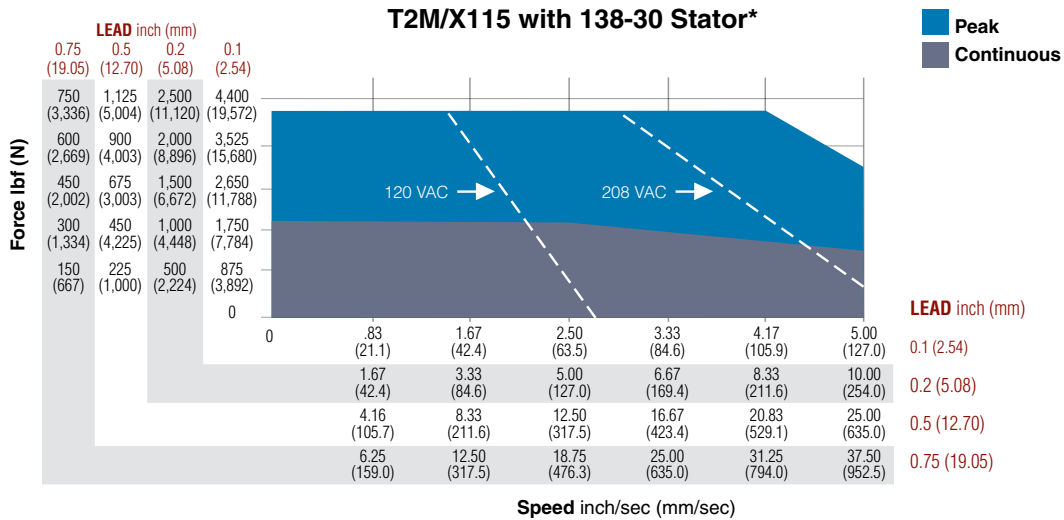

\*T2X peak force for 0.1 inch lead is 5400 lbf (24020 N). T2M peak force for 0.1 inch lead limited to 3966 lbf (17,642 N).

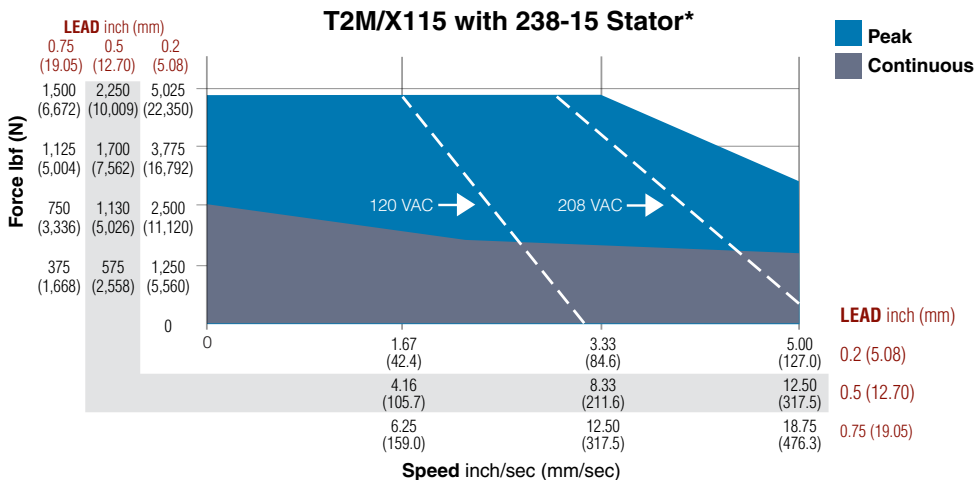

\*Test data derived using NEMA recommended aluminum heatsink 12" x 12" x 1/2".

# R2M Rotary Motor Speed vs. Torque Curves

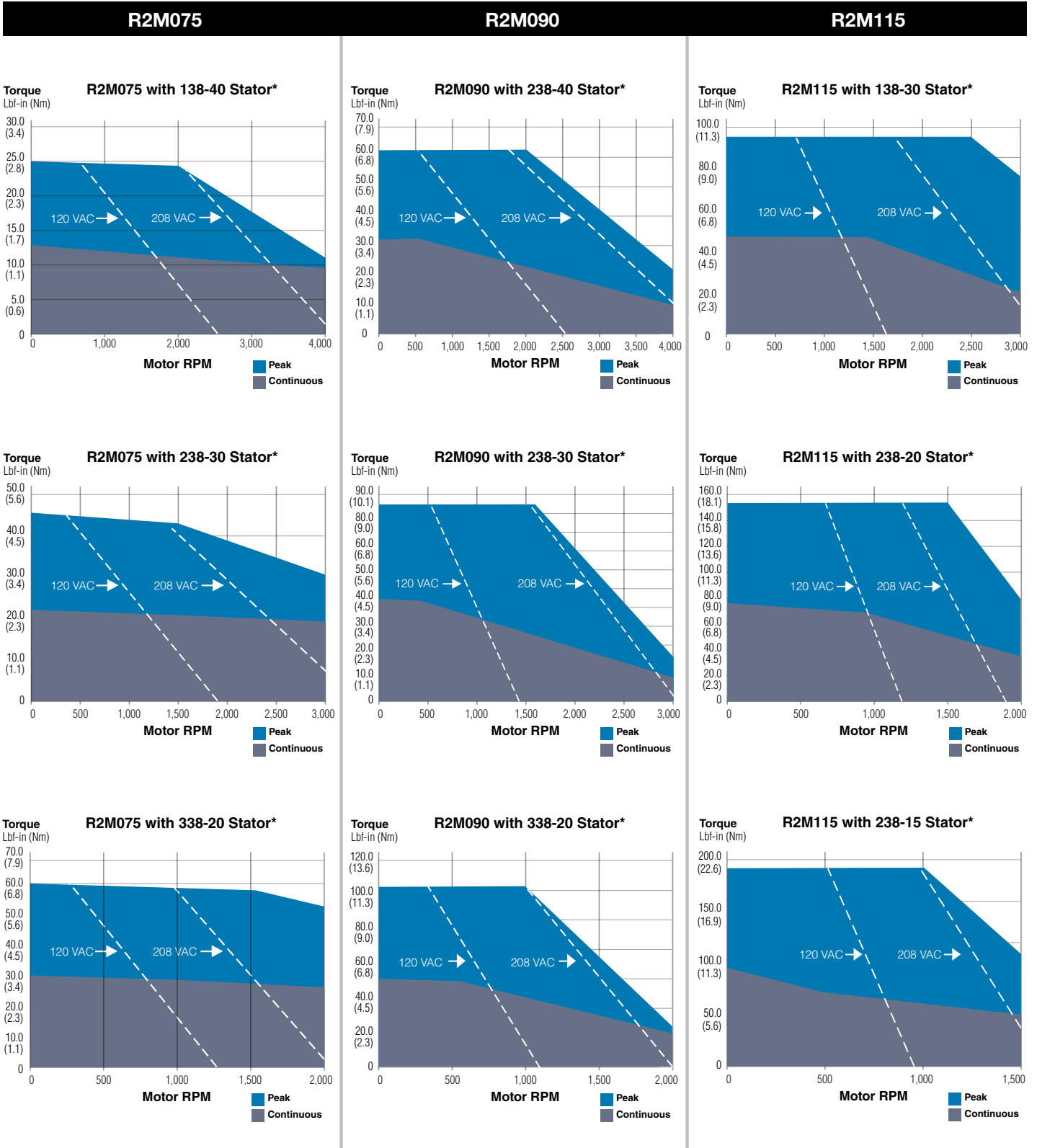

For R2G gearmotors, multiply torque by gear ratio and efficiency. Efficiencies: Divide speed by gear ratio; 1 Stage = 0.91, 2 Stage = 0.86

\*R2M075 and R2M090 test data derived using NEMA recommended aluminum heatsink 10" x 10" x 3/8".

\*R2M115 test data derived using NEMA recommended aluminum heatsink 12" x 12" x 1/2".

# T2M/X Linear Actuator Performance Specifications

## T2M/X075 Linear Actuator Performance Specifications

<b>Backlash</b>		in (mm)			.008 (.20)
<b>Lead Accuracy</b>		in/ft (mm/300 mm)			.001 (.025)
<b>Maximum Radial Load</b>		lb (N)			15 (67)
<b>Environmental Rating: Std</b>					IP54 / IP65S
		<b>Stator</b>	<b>1 Stack 138-40</b>	<b>2 Stack 238-30</b>	<b>3 Stack 338-20</b>
<b>Lead</b>		<b>RPM @ 240 VAC</b>	<b>4000</b>	<b>3000</b>	<b>2000</b>
<b>0.1</b>	<b>Continuous Stall Force</b>	lbf (N)	589 (2,620)	1,037 (4,613)	NA
	<b>Peak Force</b>	lbf (N)	1,178 (5,240)	2,073 (9,221)***	NA
	<b>Max. Speed</b>	in/sec (mm/sec)	6.67 (169)	5.00 (127)	NA
<b>0.2</b>	<b>Continuous Stall Force</b>	lbf (N)	334 (1,486)	587 (2,611)	801 (3,563)
	<b>Peak Force</b>	lbf (N)	668 (2,971)	1,175 (5,227)	1,602 (7,126)
	<b>Ma. Speed</b>	in/sec (mm/sec)	13.33 (339)	10.00 (254)	6.67 (169)
<b>0.5</b>	<b>Continuous Stall Force</b>	lbf (N)	141 (627)	249 (1,108)	339 (1,508)
	<b>Peak Force</b>	lbf (N)	283 (1,259)	498 (2,215)	679 (3,020)
	<b>Max. Speed</b>	in/sec (mm/sec)	33.33 (847)	25.00 (635)	16.67 (423)
<b>Drive Current @ Continuous Stall Force</b>		Amps	3.3	4	4
<b>Available Stroke Lengths</b>		in (mm)	3 (76), 6 (150), 10 (254), 12 (305), 14 (356), 18 (457)		
<b>Approximate Weight</b>		lb (kg)	10.8 (4.9) for 3 inch stroke, 1 stack. Add 1.1 (0.5) per inch of stroke. Add 1.1 (0.5) per motor stack. Add .8 (0.4) for brake.		
<b>Operating Temperature Range*</b>			-20C to 65C (-40°C available, consult Exlar)		
<b>Continuous AC Input Current**</b>		Amps	4	5	5

\* Ratings based on 40°C conditions.

\*\* Continuous input current rating is defined by UL and CSA.

\*\*\* T2X peak force for 0.1 inch lead is 2073 lbf (9221 N). T2M peak force for 0.1 inch lead limited to 1620 lbf (7206 N).  
For dynamic load ratings see page 12.



# T2M/X Linear Actuator Performance Specifications

## T2M/X090 Linear Actuator Performance Specifications

<b>Backlash</b>		in (mm)	.008 (.20)		
<b>Lead Accuracy</b>		in/ft (mm/300 mm)	.001 (.025)		
<b>Maximum Radial Load</b>		lb (N)	15 (67)		
<b>Environmental Rating: Std</b>			IP54 / IP65S		
		<b>Stator</b>	<b>1 Stack 138-40</b>	<b>2 Stack 238-40</b>	<b>2 Stack 238-30</b>
<b>Lead</b>		<b>RPM @ 240 VAC</b>	<b>4000</b>	<b>4000</b>	<b>3000</b>
<b>0.1</b>	<b>Continuous Stall Force</b>	lbf (N)	1,130 (5062)	1,488 (6619)	NA
	<b>Peak Stall Force</b>	lbf (N)	2,260 (10053)	2,700 (12010)***	NA
	<b>Max Speed</b>	in/sec (mm/sec)	6.67 (169)	6.67 (169)	NA
<b>0.2</b>	<b>Continuous Stall Force</b>	lbf (N)	640 (2847)	843 (3750)	1,113 (4951)
	<b>Peak Stall Force</b>	lbf (N)	1,281 (5698)	1,687 (7504)	2,225 (9897)
	<b>Max Speed</b>	in/sec (mm/sec)	13.33 (338)	13.33 (338)	10.00 (254)
<b>0.5</b>	<b>Continuous Stall Force</b>	lbf (N)	271 (1205)	357 (1588)	471 (2095)
	<b>Peak Stall Force</b>	lbf (N)	542 (2410)	714 (3176)	942 (4190)
	<b>Max Speed</b>	in/sec (mm/sec)	33.33 (846)	33.33 (846)	25.00 (635)
<b>Drive Current @ Continuous Stall Force</b>		Amps	5.7	7.5	7.5
<b>Available Stroke Lengths</b>		in (mm)	3 (75), 6 (150), 10 (254), 12 (300), 18 (450)		
<b>Approximate Weight</b>		lb (kg)	14 (6.35) for 3 inch stroke, 1 stack. Add 1 (0.5) per inch of stroke. Add 3 (1.4) per motor stack. Add 3 (1.4) for brake.		

<b>Operating Temperature Range*</b>	-20 to 65° C (-40°C available, consult Exlar)			
<b>Continuous AC Input Current**</b>	Amps	6.3	6.3	6.3

\*Ratings based on 25°C conditions.

For dynamic load ratings see page 12.

\*\*Continuous input current rating is defined by UL and CSA.

\*\*\* T2X peak force for 0.1 inch lead is 2700 lbf (12010 N). T2M peak force for 0.1 inch lead limited to 1620 lbf (7206 N).

## T2M/X115 Linear Actuator Performance Specifications

<b>Backlash</b>		in (mm)	.008 (.20)		
<b>Lead Accuracy</b>		in/ft (mm/300 mm)	.001 (.025)		
<b>Maximum Radial Load</b>		lb (N)	15 (67)		
<b>Environmental Rating: Std</b>			IP54 / IP65S		
		<b>Stator</b>	<b>1 Stack 138-30</b>	<b>2 Stack 238-20</b>	<b>2 Stack 238-15</b>
<b>Lead</b>		<b>RPM @ 240 VAC</b>	<b>3000</b>	<b>2000</b>	<b>1500</b>
<b>0.1</b>	<b>Continuous Stall Force</b>	lbf (N)	2,060 (9,163)	3,224 (14,341)	NA
	<b>Peak Stall Force</b>	lbf (N)	4,120 (18,327)	5,400 (24,020)	NA
	<b>Max Speed</b>	in/sec (mm/sec)	5.00 (127)	3.33 (84)	NA
<b>0.2</b>	<b>Continuous Stall Force</b>	lbf (N)	1,177 (5,235)	1,843 (8,198)	2,380 (10,586)
	<b>Peak Stall Force</b>	lbf (N)	2,354 (10,471)	3,685 (16,392)	4,760 (21,174)
	<b>Max Speed</b>	in/sec (mm/sec)	10.00 (254)	6.67 (169)	5.00 (127)
<b>0.5</b>	<b>Continuous Stall Force</b>	lbf (N)	530 (2,358)	829 (3,688)	1,071 (4,764)
	<b>Peak Stall Force</b>	lbf (N)	1,059 (4711)	1,658 (7,375)	2,142 (9,528)
	<b>Max Speed</b>	in/sec (mm/sec)	25.00 (635)	16.67 (423)	12.50 (317)
<b>0.75</b>	<b>Continuous Stall Force</b>	lbf (N)	353 (1,570)	553 (2,460)	714 (3,176)
	<b>Peak Stall Force</b>	lbf (N)	706 (3,140)	1,106 (4,920)	1,428 (6,352)
	<b>Max Speed</b>	in/sec (mm/sec)	37.5 (953)	25 (635)	17.75 (450)
<b>Drive Current @ Continuous Stall Force</b>		Amps	8.5	8.5	8.5
<b>Available Stroke Lengths</b>		in (mm)	4 (102), 6 (150), 10 (254), 12 (300), 18 (450)		
<b>Approximate Weight</b>		lb (kg)	34 (15.5) for 6 inch stroke, 1 stack. Add 2 (1) per inch of stroke. Add 8 (4) per motor stack. Add 4 (2) for brake.		

<b>Operating Temperature Range*</b>	-20 to 65° C (-40°C available, consult Exlar)			
<b>Continuous AC Input Current**</b>	Amps	8.3	8.3	8.3

\*Ratings based on 25°C conditions.

For dynamic load ratings see page 12.

\*\*Continuous input current rating is defined by UL and CSA.

\*\*\* T2X peak force for 0.1 inch lead is 5400 lbf (24020 N). T2M peak force for 0.1 inch lead limited to 3966 lbf (17,642 N).

# R2M/R2G075 Rotary Motor/Gearmotor Performance Specifications

## R2M075 Rotary Motor Torque and Speed Ratings

	Stator	1 Stack 138-40	2 Stack 238-30	2 Stack 238-20
	RPM at 240 VAC	4000	3000	2000
<b>Continuous Stall Torque</b>	lbf-in (Nm)	12 (1.4)	22 (2.5)	30 (3.4)
<b>Peak Torque</b>	lbf-in (Nm)	25 (2.8)	44 (4.9)	60 (6.8)
<b>Drive Current @ Continuous Stall Torque</b>	Amps	3.3	4.0	4.0
<b>Operating Temperature Range*</b>	-20 to 65° C (-40° C available, consult Exlar)			
<b>Continuous AC Input Current**</b>	Amps	4	5	5

\*Ratings based on 40°C ambient conditions.

\*\*Continuous input current rating is defined by UL and CSA.

For output torque of R2G gearmotors, multiply by ratio and efficiency. Please note maximum allowable output torques shown below.

## R2M/R2G075 Inertia

	Stator	1 Stack	2 Stack	3 Stack
<b>R2M Motor Armature Inertia (+/-5%)</b>	lb-in-sec <sup>2</sup> (kg-cm <sup>2</sup> )	0.000545 (0.6158)	0.000973 (1.0996)	0.001401 (1.5834)
<b>R2G Gearmotor Armature Inertia* (+/-5%)</b>	lb-in-sec <sup>2</sup> (kg-cm <sup>2</sup> )	0.000660 (0.7450)	0.001068 (1.2057)	0.001494 (1.6868)

\*Add armature inertia to gearing inertia for total R2G system inertia.

## Radial Load and Bearing Life

	RPM	50	100	250	500	1000	3000
	<b>R2M075</b> lbf (N)	278 (1237)	220 (979)	162 (721)	129 (574)	102 (454)	71 (316)
<b>R2G075</b> lbf (N)	343 (1526)	272 (1210)	200 (890)	159 (707)	126 (560)	88 (391)	

Side load ratings shown above are for 10,000 hour bearing life at 25mm from motor face at given rpm.

## R2G075 Gearmotor Mechanical Ratings

Model	Ratio	Maximum Allowable Output Torque-Set by User lbf-in (Nm)	Output Torque at Motor Speed for 10,000 Hour Life		
			1000 RPM lbf-in (Nm)	2500 RPM lbf-in (Nm)	4000 RPM lbf-in (Nm)
R2G075-004	4:1	1618 (182.8)	384 (43.4)	292 (32.9)	254 (28.7)
R2G075-005	5:1	1446 (163.4)	395 (44.6)	300 (33.9)	260 (29.4)
R2G075-010	10:1	700 (79.1)	449 (50.7)	341 (38.5)	296 (33.9)

Two torque ratings for the R2G gearmotors are given in the table above. The left hand columns give the maximum (peak) allowable output torque for the indicated ratios of each size R2G gearmotor. This is not the rated output torque of the motor multiplied by the ratio of the reducer.

It is possible to select a configuration of the motor selection and gear ratio such that the rated motor torque, multiplied by the gear ratio exceeds these ratings. It is the responsibility of the user to ensure that the settings of the system do not allow these values to be exceeded.

The right hand columns give the output torque at the indicated speed which will result in 10,000 hour life (L10). The setup of the system will determine the actual output torque and speed.

## R2G075 Gearing Reflected Inertia

Gear Stages	Single Reduction	
	lbf-in-sec <sup>2</sup>	(kg-cm <sup>2</sup> )
4:1	0.000095	(0.107)
5:1	0.000062	(0.069)
10:1	0.000017	(0.019)

## Backlash and Efficiency

	Single Reduction	Double Reduction
<b>Backlash at 1% Rated Torque</b>	10 Arc min	13 Arc min
<b>Efficiency</b>	91%	86%

## R2M075 Motor and R2G075 Gearmotor Weights

	R2M075 without Gears	R2G075 with 1 Stage Gearing	Added Weight for Brake
<b>1 Stack Stator</b>	lb (kg)	7.4 (3.4)	0.8 (0.4)
<b>2 Stack Stator</b>	lb (kg)	9.2 (4.2)	
<b>3 Stack Stator</b>	lb (kg)	11 (4.9)	

# R2M/R2G090 Rotary Motor/Gearmotor Performance Specifications

## R2M090 Rotary Motor Torque and Speed Ratings

	Stator	2 Stack 238-40	2 Stack 238-30	3 Stack 338-20
	RPM at 240 VAC	4000	3000	2000
Continuous Stall Torque	lbf-in (Nm)	30 (3.4)	40 (4.5)	52 (5.9)
Peak Torque	lbf-in (Nm)	60 (6.8)	80 (9.0)	105 (11.9)
Drive Current @ Continuous Stall Torque	Amps	7.5	7.5	6.6
Operating Temperature Range*	-20 to 65° C (-40°C available, consult Exlar)			
Continuous AC Input Current**	Amps	6.3	6.3	6.3

\*Ratings based on 25°C ambient conditions.

For output torque of R2G gearmotors, multiply by ratio and efficiency. Please note maximum allowable output torques shown below.

\*\*Continuous input current rating is defined by UL and CSA.

## R2M/R2G090 Inertia

	Stator	2 Stack	3 Stack
R2M Motor Armature Inertia (+/-5%)	lb-in-sec <sup>2</sup> (kg-cm <sup>2</sup> )	0.00097 (1.09)	0.00140 (1.58)
R2G Gearmotor Armature Inertia* (+/-5%)	lb-in-sec <sup>2</sup> (kg-cm <sup>2</sup> )	0.00157 (1.77)	0.00200 (2.26)

\*Add armature inertia to gearing inertia for total inertia.

## Radial Load and Bearing Life

	RPM	50	100	250	500	1000	3000
R2M090 lbf (N)	427 (1899)	340 (1512)	250 (1112)	198 (881)	158 (703)	109 (485)	
R2G090 lbf (N)	350 (1557)	278 (1237)	205 (912)	163 (725)	129 (574)	89 (396)	

Side load ratings shown above are for 10,000 hour bearing life at 25mm from motor face at given rpm.

## R2G090 Gearmotor Mechanical Ratings

Model	Ratio	Maximum Allowable Output Torque-Set by User lbf-in (Nm)	Output Torque at Motor Speed for 10,000 Hour Life		
			1000 RPM lbf-in (Nm)	2500 RPM lbf-in (Nm)	4000 RPM lbf-in (Nm)
R2G090-004	4:1	2078 (234.8)	698 (78.9)	530 (59.9)	460 (51.9)
R2G090-005	5:1	1798 (203.1)	896 (101.2)	680 (76.8)	591 (66.8)
R2G090-010	10:1	1126 (127.2)	1043 (117.8)	792 (89.4)	688 (77.7)
R2G090-016	16:1	2078 (234.8)	1057 (119.4)	803 (90.7)	698 (78.9)
R2G090-020	20:1	2078 (234.8)	1131 (127.8)	859 (97.1)	746 (84.3)
R2G090-025	25:1	1798 (203.1)	1452 (164.1)	1103 (124.6)	958 (108.2)
R2G090-040	40:1	2078 (234.8)	1392 (157.3)	1057 (119.4)	918 (103.7)
R2G090-050	50:1	1798 (203.1)	1787 (201.9)	1358 (153.4)	1179 (133.2)
R2G090-100	100:1	1126 (127.2)	1100 (124.3)	1100 (124.3)	1100 (124.3)

Two torque ratings for the R2G gearmotors are given in the table above. The left hand columns give the maximum (peak) allowable output torque for the indicated ratios of each size R2G gearmotor. This is not the rated output torque of the motor multiplied by the ratio of the reducer.

It is possible to select a configuration of the motor selection and gear ratio such that the rated motor torque, multiplied by the gear ratio exceeds these ratings. It is the responsibility of the user to ensure that the settings of the system do not allow these values to be exceeded.

The right hand columns give the output torque at the indicated speed which will result in 10,000 hour life (L10). The setup of the system will determine the actual output torque and speed.

## R2G090 Gearing Reflected Inertia

Gear Stages	Single Reduction		Double Reduction	
	lbf-in-sec <sup>2</sup>	(kg-cm <sup>2</sup> )	Gear Stages	lbf-in-sec <sup>2</sup> (kg-cm <sup>2</sup> )
4:1	0.000154	(0.174)	16:1	0.000115 (0.130)
5:1	0.000100	(0.113)	20:1, 25:1	0.0000756 (0.0854)
10:1	0.0000265	(0.0300)	40:1, 50:1, 100:1	0.0000203 (0.0230)

## Backlash and Efficiency

	Single Reduction	Double Reduction
Backlash at 1% Rated Torque	10 Arc min	13 Arc min
Efficiency	91%	86%

## R2M090 Motor and RTG090 Gearmotor Weights

	R2M090 without Gears	R2G090 with 1 Stage Gearing	R2G090 with 2 Stage Gearing	Added Weight for Brake
1 Stack Stator lb (kg)	11 (4.9)	19 (8.6)	22 (10)	3 (1.4)
2 Stack Stator lb (kg)	14 (6.4)	22 (10)	25 (11.3)	
3 Stack Stator lb (kg)	17 (7.7)	25 (11.3)	28 (12.7)	

# R2M/R2G115 Rotary Motor/Gearmotor Performance Specifications

## R2M115 Rotary Motor Torque and Speed Ratings

	Stator	1 Stack 138-30	2 Stack 238-20	2 Stack 238-15
	RPM at 240 VAC	3000	2000	1500
<b>Continuous Stall Torque</b>	lbf-in (Nm)	47 (5.3)	73 (8.3)	95 (10.7)
<b>Peak Torque</b>	lbf-in (Nm)	94 (10.6)	146 (16.5)	190 (21.5)
<b>Drive Current @ Continuous Stall Torque</b>	Amps	8.5	8.5	8.5
<b>Operating Temperature Range*</b>	-20 to 65° C (-40° C available, consult Exlar)			
<b>Continuous AC Input Current**</b>	Amps	8.3	8.3	8.3

\*Ratings based on 25°C ambient conditions.

For output torque of R2G gearmotors, multiply by ratio and efficiency.

\*\*Continuous input current rating is defined by UL and CSA.

Please note maximum allowable output torques shown below.

## R2M/R2G115 Inertia

	Stator	1 Stack	2 Stack
<b>R2M Motor Armature Inertia (+/-5%)</b>	lb-in-sec <sup>2</sup> (kg-cm <sup>2</sup> )	0.00344 (3.89)	0.00623 (7.036)
<b>R2G Gearmotor Armature Inertia*</b>	lb-in-sec <sup>2</sup> (kg-cm <sup>2</sup> )	0.00538 (6.08)	0.00816 (9.22)

\*Add armature inertia to gearing inertia for total R2M system inertia.

## Radial Load and Bearing Life

	RPM	50	100	250	500	1000	3000
<b>R2M115</b> lbf (N)	579 (2576)	460 (2046)	339 (1508)	269 (1197)	214 (952)	148 (658)	
<b>R2G115</b> lbf (N)	858 (3817)	681 (3029)	502 (2233)	398 (1770)	316 (1406)	218 (970)	

Side load ratings shown above are for 10,000 hour bearing life at 25mm from motor face at given rpm.

## R2G115 Gearmotor Mechanical Ratings

Model	Ratio	Maximum Allowable Output Torque-Set by User lbf-in (Nm)	Output Torque at Motor Speed for 10,000 Hour Life		
			1000 RPM lbf-in (Nm)	2000 RPM lbf-in (Nm)	3000 RPM lbf-in (Nm)
R2G115-004	4:1	4696 (530.4)	1392 (157.3)	1132 (127.9)	1000 (112.9)
R2G115-005	5:1	4066 (459.4)	1455 (163.3)	1175 (132.8)	1040 (117.5)
R2G115-010	10:1	2545 (287.5)	1660 (187.6)	1350 (152.6)	1200 (135.6)
R2G115-016	16:1	4696 (530.4)	2112 (238.6)	1714 (193.0)	1518 (171.0)
R2G115-020	20:1	4696 (530.4)	2240 (253.1)	1840 (207.9)	1620 (183.0)
R2G115-025	25:1	4066 (459.4)	2350 (265.5)	1900 (214.7)	1675 (189.2)
R2G115-040	40:1	4696 (530.4)	2800 (316.4)	2240 (253.1)	2000 (225.9)
R2G115-050	50:1	4066 (459.4)	2900 (327.7)	2350 (265.5)	2100 (237.3)
R2G115-100	100:1	2545 (287.5)	2500 (282.5)	2500 (282.5)	2400 (271.2)

Two torque ratings for the R2G gearmotors are given in the table above. The left hand columns give the maximum (peak) allowable output torque for the indicated ratios of each size R2G gearmotor. This is not the rated output torque of the motor multiplied by the ratio of the reducer.

It is possible to select a configuration of the motor selection and gear ratio such that the rated motor torque, multiplied by the gear ratio exceeds these ratings. It is the responsibility of the user to ensure that the settings of the system do not allow these values to be exceeded.

The right hand columns give the output torque at the indicated speed which will result in 10,000 hour life (L10). The setup of the system will determine the actual output torque and speed.

## R2G115 Gearing Reflected Inertia

Single Reduction			Double Reduction		
Gear Stages	lbf-in-sec <sup>2</sup>	(kg-cm <sup>2</sup> )	Gear Stages	lbf-in-sec <sup>2</sup>	(kg-cm <sup>2</sup> )
4:1	0.000635	(0.717)	16:1	0.000513	(0.580)
5:1	0.000428	(0.484)	20:1, 25:1	0.000350	(0.396)
10:1	0.000111	(0.125)	40:1, 50:1, 100:1	0.0000911	(0.103)

## Backlash and Efficiency

	Single Reduction	Double Reduction
<b>Backlash at 1% Rated Torque</b>	10 Arc min	13 Arc min
<b>Efficiency</b>	91%	86%

## R2M115 Motor and RTG115 Gearmotor Weights

	R2M115 without Gears	R2G115 with 1 Stage Gearing	R2G115 with 2 Stage Gearing	Added Weight for Brake
<b>1 Stack Stator</b>	lb (kg)	19 (8.6)	34 (15.4)	4 (2)
<b>2 Stack Stator</b>	lb (kg)	27 (12.2)	42 (19.1)	
<b>3 Stack Stator</b>	lb (kg)	35 (15.9)	50 (22.7)	



# T2M/X075 Linear Actuator Dimensions

## T2M/X075 Double Side Mount or Extended Tie Rod Mount

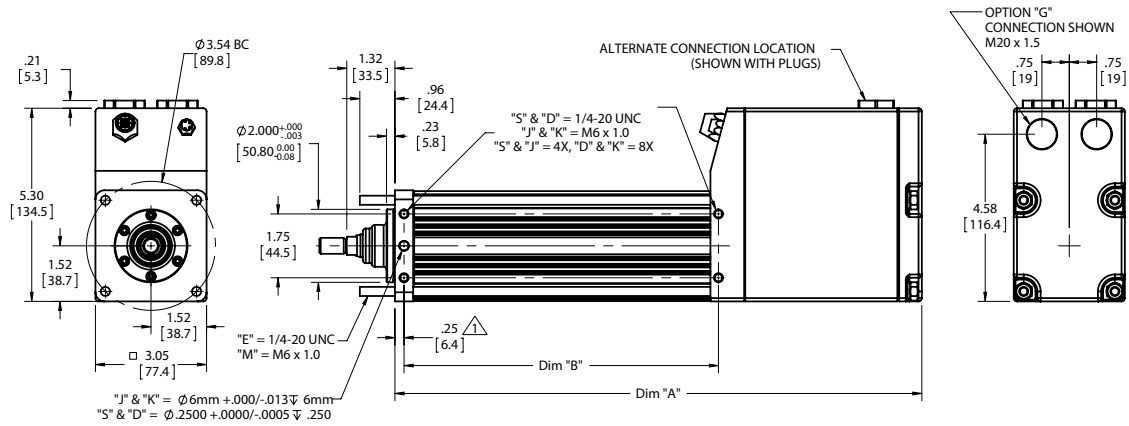

## T2M/X075 Side Trunnion Mount or Rear Clevis Mount

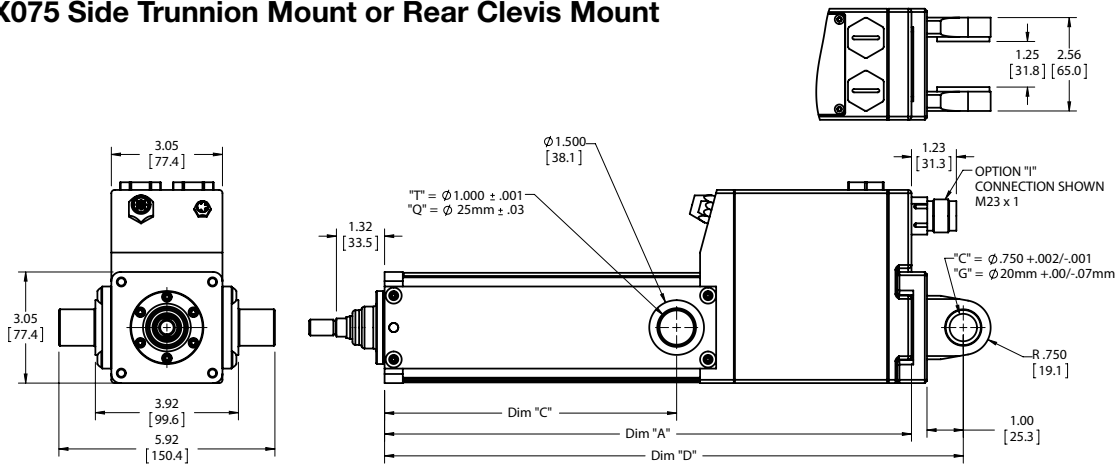

## T2M/X075 Front, Rear, or Front and Rear Flange Mount

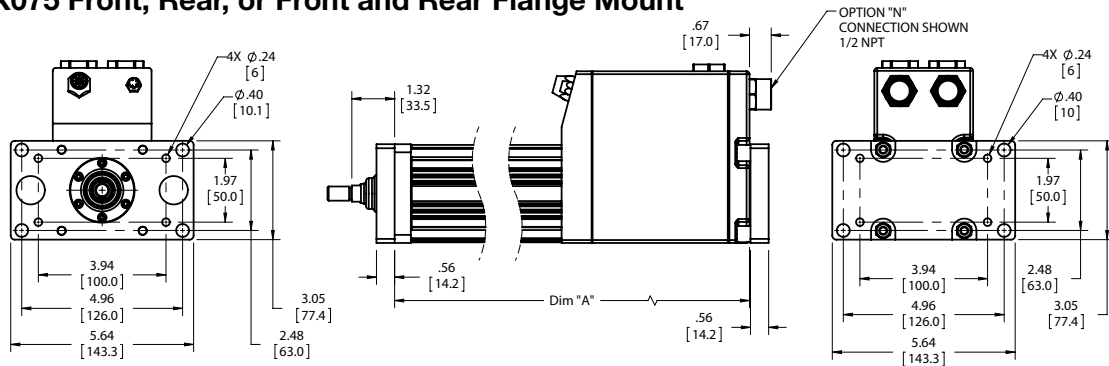

DIM	3 inch (75 mm) stroke in (mm)	6 inch (150 mm) stroke in (mm)	10 inch (250 mm) stroke in (mm)	12 inch (300 mm) stroke in (mm)	14 inch (350 mm) stroke in (mm)	18 inch (450 mm) stroke in (mm)
A	11.98 (304.3)	14.45 (367.0)	18.95 (481.3)	20.95 (532.1)	22.95 (582.9)	26.95 (684.5)
B	6.15 (156.2)	8.62 (218.9)	13.12 (333.2)	15.12 (384.0)	17.12 (434.8)	21.12 (536.4)
C	5.38 (136.7)	8.00 (203.2)	10.00 (254.0)	12.00 (304.8)	14.00 (355.6)	18.00 (457.2)
D	13.40 (340.4)	15.87 (403.1)	20.37 (517.4)	22.37 (568.2)	24.37 (619.0)	28.37 (720.6)

Note: Add 1.61 inches to dimensions "A", "B" and "D" if ordering a brake. Add 1.2 inches to dimensions "A", "C" and "D" and dimension if ordering a splined main rod.

# T2M/X090 Linear Actuator Dimensions

## T2M/X090 Double Side Mount or Extended Tie Rod Mount

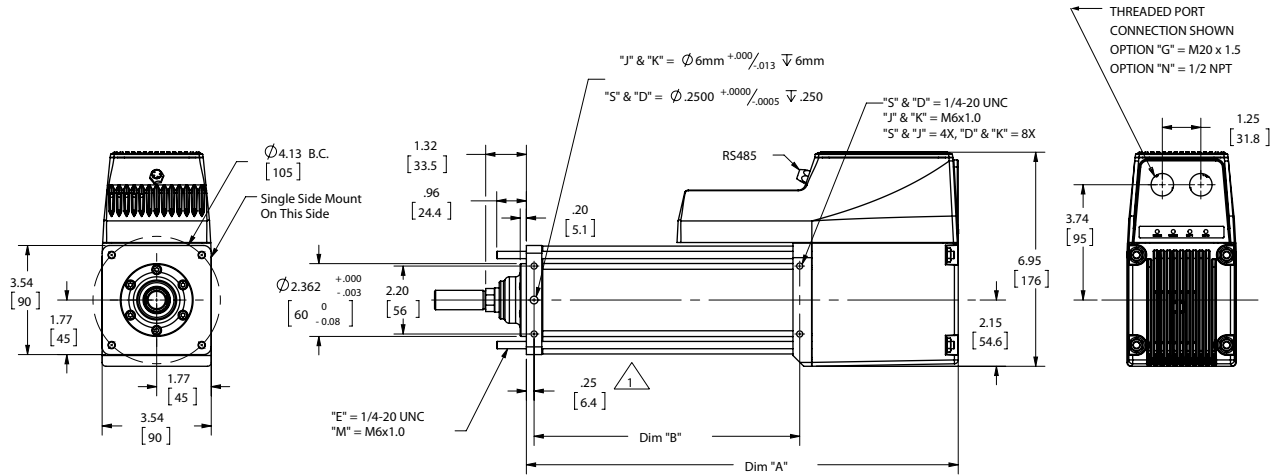

## T2M/X090 Side Trunnion Mount or Rear Clevis Mount

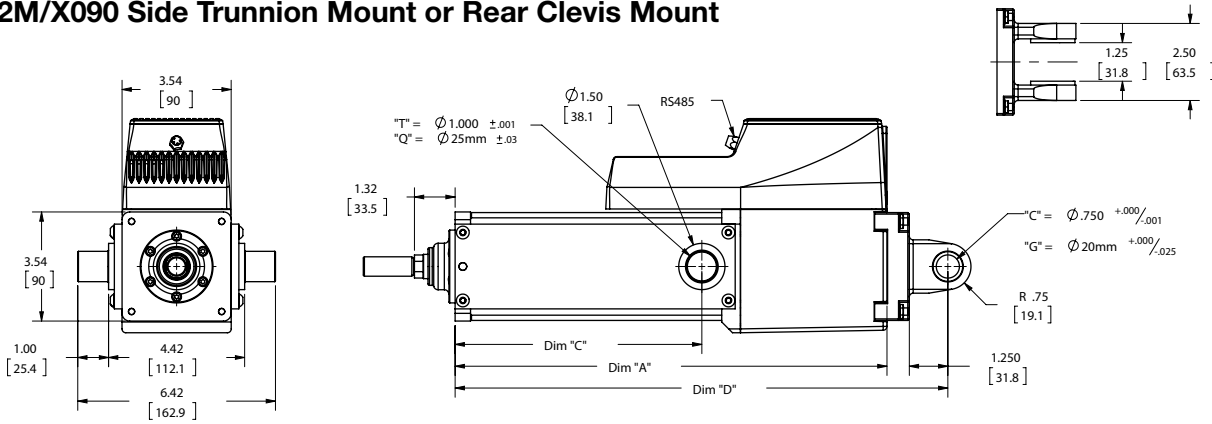

## T2M/X090 Front, Rear, or Front and Rear Flange Mount

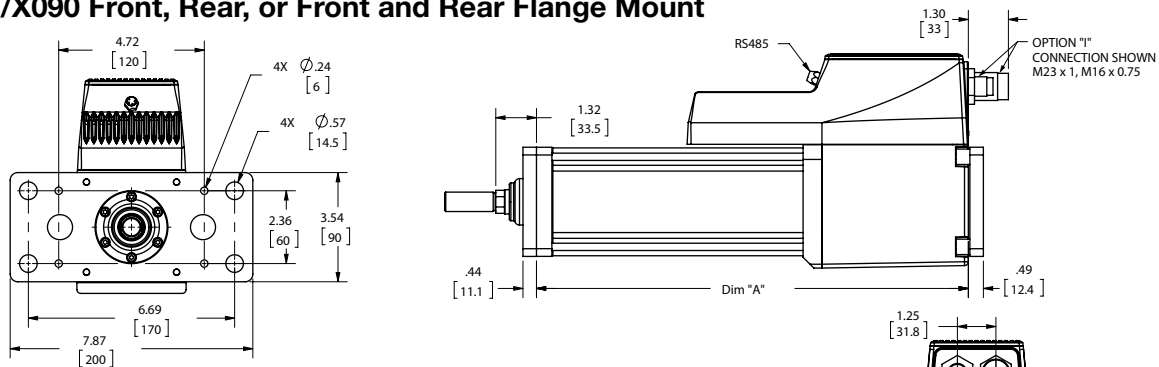

DIM	3 inch (75 mm) stroke in (mm)	6 inch (150 mm) stroke in (mm)	10 inch (250 mm) stroke in (mm)	12 inch (300 mm) stroke in (mm)	18 inch (450 mm) stroke in (mm)
A	11.54 (293.1)	14.01 (355.9)	18.53 (470.7)	20.53 (521.5)	26.53 (673.9)
B	6.15 (156.1)	8.62 (218.9)	13.12 (333.3)	15.12 (434.8)	21.12 (536.4)
C	5.38 (136.7)	8.01 (203.4)	10.00 (254.0)	12.00 (304.8)	18.00 (457.2)
D	13.52 (343.3)	15.99 (406.1)	20.49 (520.4)	22.49 (571.2)	28.49 (723.6)

Note: Add 1.61 inches to dimensions "A", "B" and "D" if ordering a brake. Add 1.78 inches to dimensions "A", "C" and "D" and dimension if ordering a splined main rod.

# T2M/X115 Linear Actuator Dimensions

## T2M/X115 Double Side Mount or Extended Tie Rod Mount

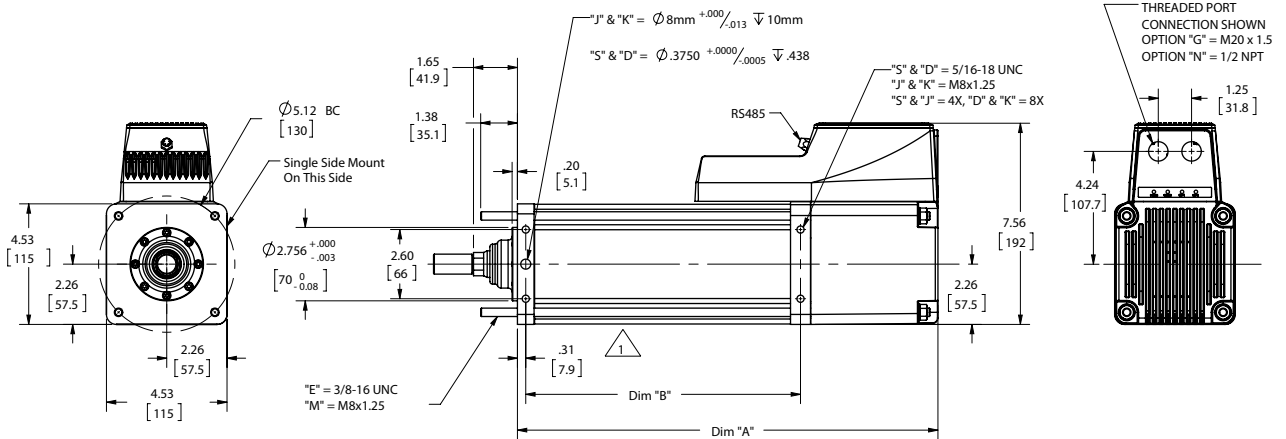

## T2M/X115 Side Trunnion Mount or Rear Clevis Mount

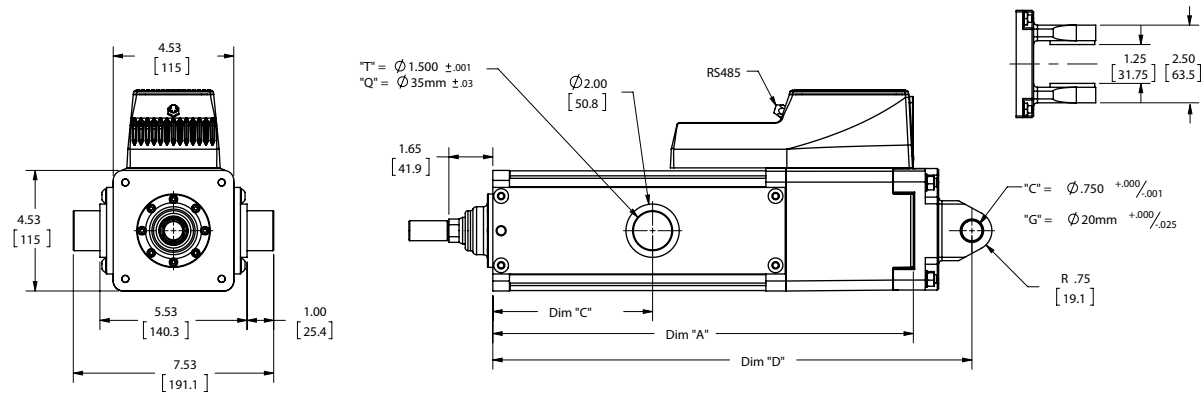

## T2M/X115 Front, Rear, or Front and Rear Flange Mount

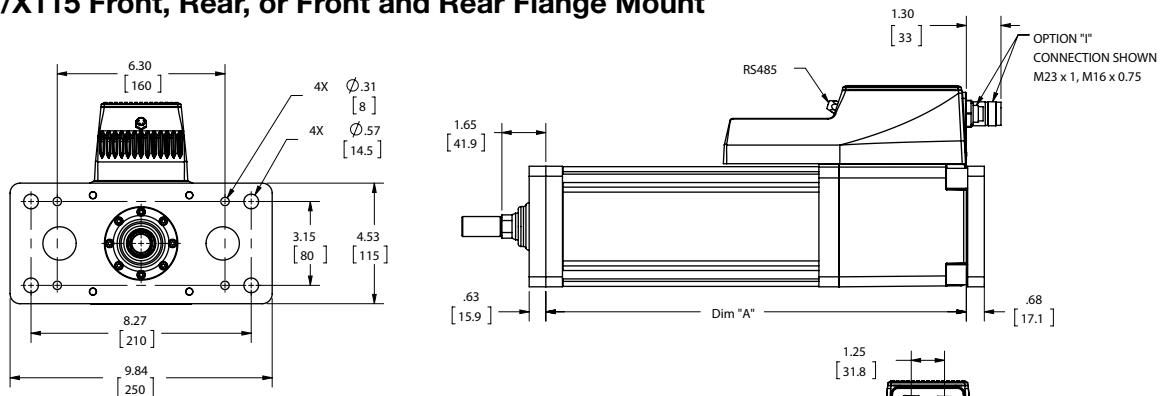

DIM	4 inch (102 mm) stroke in (mm)	6 inch (152 mm) stroke in (mm)	10 inch (254 mm) stroke in (mm)	12 inch (305 mm) stroke in (mm)	18 inch (457 mm) stroke in (mm)
A	13.79 (350.3)	15.79 (401.1)	19.79 (502.7)	21.79 (553.5)	27.79 (705.9)
B	8.31 (211.1)	10.31 (261.8)	14.31 (363.5)	16.31 (414.3)	22.31 (566.7)
C	4.00 (101.6)	6.00 (152.4)	10.00 (254.0)	12.00 (304.8)	18.00 (457.2)
D	15.99 (406.1)	17.99 (456.9)	21.99 (558.5)	23.99 (609.3)	29.99 (761.7)

Note: Add 2.33 inches to dimensions "A", "B" and "D" if ordering a brake. Add 1.77 inches to dimensions "A", "C" and "D" and dimension if ordering a splined  $\triangle$  main rod.

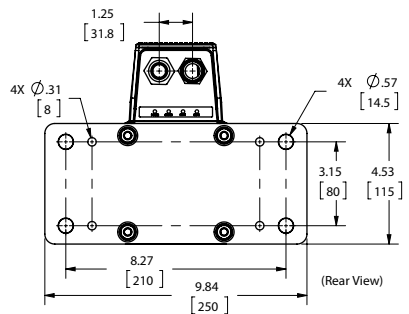

# T2M/X Options and Rod End Attachment Dimensions

## Anti-Rotate Option

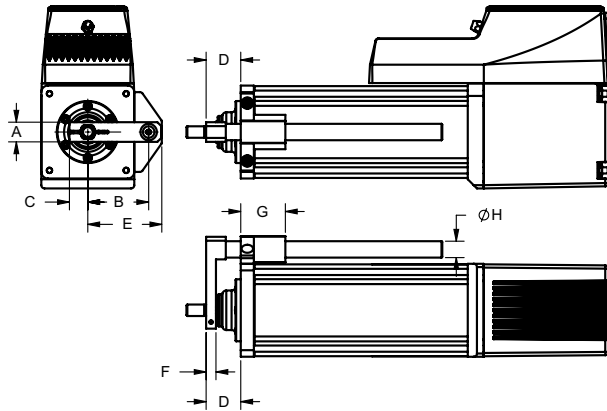

DIM inch (mm)	T2M/X075	T2M/X090	T2M/X115
<b>A</b>	0.82 (20.8)	0.75 (19.1)	1.13 (28.7)
<b>B</b>	2.20 (56.0)	2.32 (58.9)	3.06 (77.7)
<b>C</b>	0.60 (15.3)	0.70 (17.8)	1.00 (25.4)
<b>D</b>	1.32 (33.5)	1.32 (33.5)	1.65 (41.9)
<b>E</b>	2.70 (68.7)	2.82 (71.6)	3.63 (92.2)
<b>F</b>	0.39 (9.9)	0.38 (9.7)	0.50 (12.7)
<b>G</b>	1.70 (43.2)	1.70 (43.2)	1.97 (50.0)
<b>ØH</b>	0.63 (16.0)	0.63 (16.0)	0.75 (19.1)

## Actuator Rod End Option

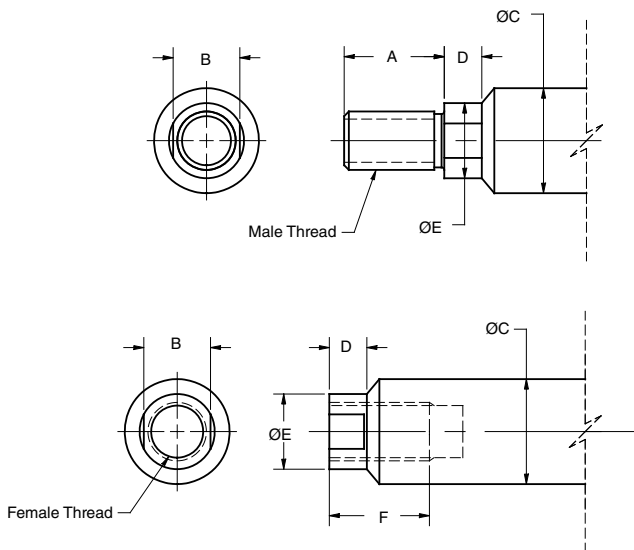

DIM inch (mm)	T2M/X075	T2M/X090	T2M/X115
<b>A</b>	0.750 (19.1)	1.250 (31.8)	1.500 (38.1)
<b>B</b>	0.500 (12.7)	0.625 (17.0)	0.750 (19.1)
<b>ØC</b>	0.625 (15.9)	0.787 (20.0)	1.000 (25.4)
<b>D</b>	0.281 (7.1)	0.281 (7.1)	0.381 (9.7)
<b>ØE</b>	0.562 (14.3)	0.725 (18.4)	0.875 (22.2)
<b>F</b>	0.750 (19.1)	1.000 (25.4)	1.000 (25.4)
<b>Male-Inch "M", "W"</b>	7/16-20 UNF-2A	1/2-20 UNF-2A	3/4-16 UNF-2A
<b>Male-Metric "A", "R"</b>	M12 x 1.75 6g	M16 x 1.5 6g	M16 x 1.5 6g
<b>Female-Inch "F", "V"</b>	7/16-20 UNF-2B	1/2-20 UNF-2B	5/8-18 UNF-2B
<b>Female-Metric "B", "L"</b>	M10 x 1.5 6h	M16 x 1.5 6h	M16 x 1.5 6h

## Clevis Pin

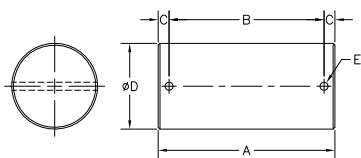

DIM	T2M/X075/T2M/X090	T2M/X075/T2M/X090	T2M/X115
inch (mm)	<b>CP050 Rod Eye, Rod Clevis</b>	<b>CP075 Rear Clevis</b>	<b>CP075 Rod Eye, Rod Clevis, Spherical Eye, Rear Clevis</b>
<b>A</b>	2.28 (57.9)	3.09 (78.5)	3.09 (78.5)
<b>B</b>	1.94 (49.28)	2.72 (69.1)	2.72 (69.1)
<b>C</b>	0.17 (4.32)	0.19 (4.82)	1.19 (4.82)
<b>ØD</b>	0.50 -0.001/-0.002 (12.7 mm +0.00/-0.05)	0.75 -0.001/-0.002 (19.1 mm +0.00/-0.05)	0.75 -0.001/-0.002 (19.1 mm +0.00/-0.05)
<b>ØE</b>	0.106 (2.69)	0.14 (3.56)	0.14 (3.56)



# T2M/X Rod End Attachment Dimensions

## Spherical Rod Eye

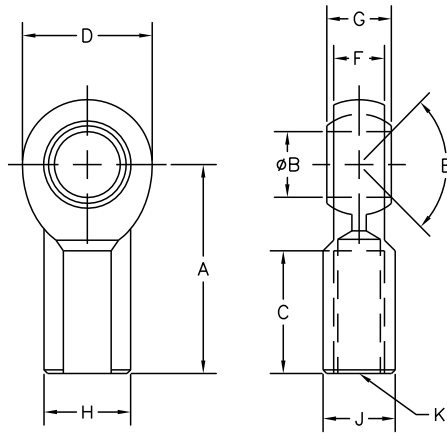

DIM inch (mm)	T2M/X075	T2M/X090	T2M/X115
	SRM044	SRM050	SRM075
A	1.81 (46.0)	2.125 (54.0)	2.88 (73.2)
$\phi B$	0.438 (11.13)	0.500 (12.7)	0.75 (19.1)
C	1.06 (26.9)	1.156 (29.4)	1.72 (43.7)
D	1.13 (28.7)	1.312 (33.3)	1.75 (44.5)
E	14 Deg	6 Deg	14 Deg
F	0.44 (11.1)	0.500 (12.7)	0.69 (17.5)
G	0.56 (14.2)	0.625 (15.9)	0.88 (22.3)
H	0.75 (19.1)	0.875 (22.2)	1.13 (28.7)
J	0.63 (16.0)	0.750 (19.1)	1.00 (25.4)
K	7/16-20	1/2-20	3/4-16

## Rod Eye

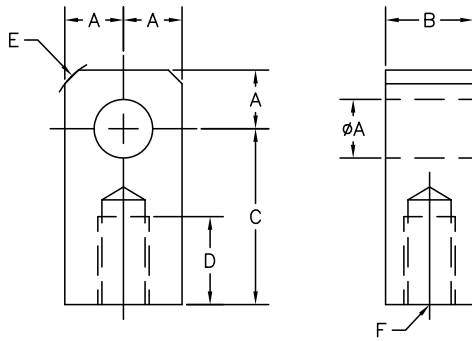

DIM inch (mm)	T2M/X075	T2M/X090	T2M/X115
	RE050	REI050	RE075
$\phi A$	0.50 (12.7)	0.50 (12.7)	0.75 (19.05)
B	0.75 (19.1)	0.75 (19.05)	1.25 (31.8)
C	1.50 (38.1)	1.50 (38.1)	2.06 (52.3)
D	0.75 (19.1)	0.75 (19.05)	1.13 (28.7)
E	0.63 (15.9)	0.375 (9.53)	0.88 (22.2)
F	7/16-20	1/2-20	3/4-16

## Rod Clevis

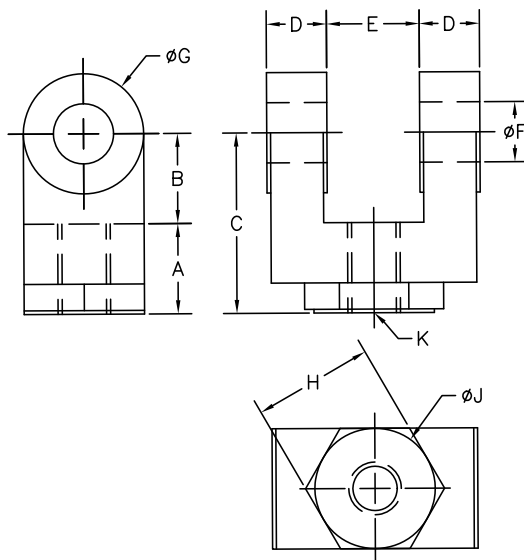

DIM inch (mm)	T2M/X075	T2M/X090	T2M/X115
	RC050	RCI050	RC075
A	0.750 (19.05)	0.750 (19.05)	1.125 (28.58)
B	0.750 (19.05)	0.750 (19.05)	1.25 (31.75)
C	1.500 (38.1)	1.500 (38.1)	2.375 (60.3)
D	0.500 (12.7)	0.500 (12.7)	0.625 (15.88)
E	0.765 (19.43)	0.765 (19.43)	1.265 (32.12)
$\phi F$	0.500 (12.7)	0.500 (12.7)	0.75 (19.1)
$\phi G$	1.000 (25.4)	1.000 (25.4)	1.50 (38.1)
H	1.000 (25.4)	1.000 (25.4)	1.25 (31.75)
$\phi J$	1.000 (25.4)	N/A	1.25 (31.75)
K	7/16-20	1/2-20	3/4-16

# R2M/R2G075 Rotary Motor/Gearmotor Dimensions

## R2M075 Dimensions

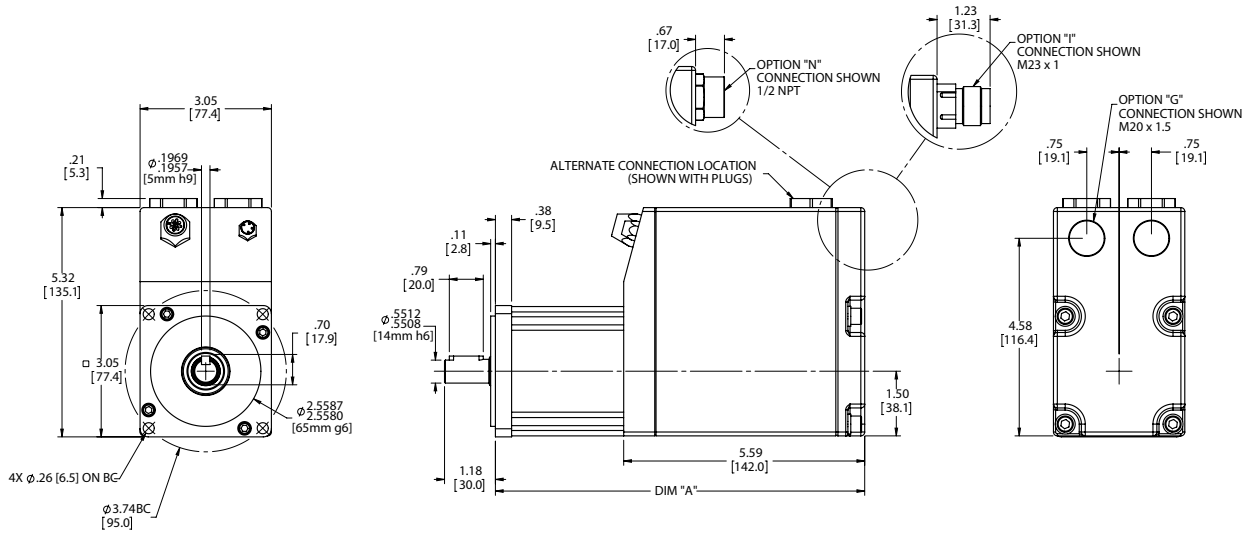

Without Brake Option			
DIM	1 Stack Stator	2 Stack Stator	3 Stack Stator
A	8.57 (217.7)	9.57 (243.1)	10.57 (268.5)

With Brake Option			
DIM	1 Stack Stator	2 Stack Stator	3 Stack Stator
A	9.85 (250.2)	10.85 (275.6)	11.85 (301.0)

## R2G075 Dimensions

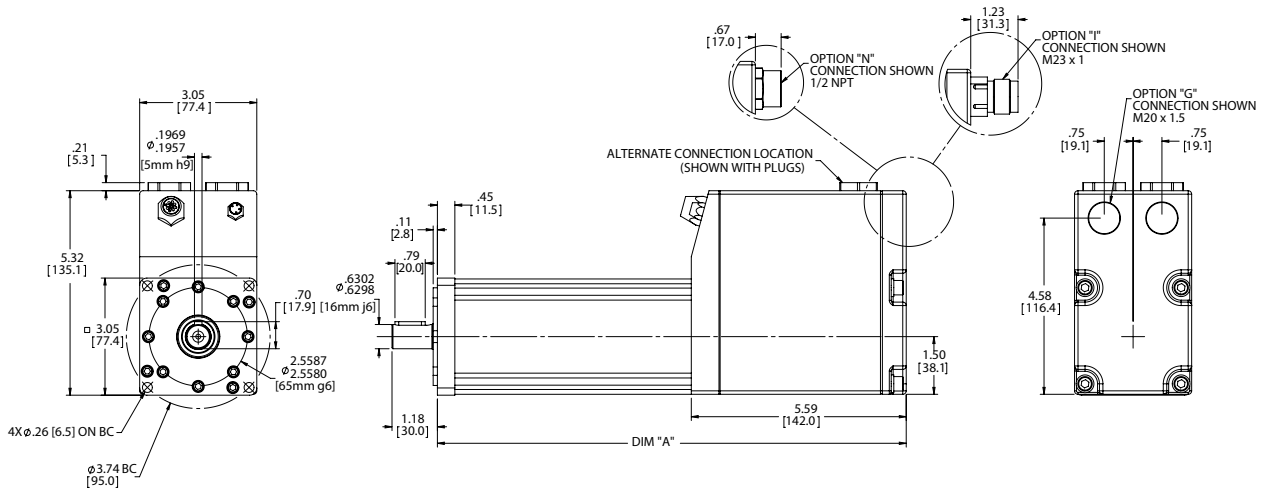

Without Brake Option			
DIM	1 Stack Stator 1 Stage Gearhead	2 Stack Stator 1 Stage Gearhead	3 Stack Stator 1 Stage Gearhead
A	10.19 (258.8)	11.19 (284.2)	12.19 (309.6)

With Brake Option			
DIM	1 Stack Stator 1 Stage Gearhead	2 Stack Stator 1 Stage Gearhead	3 Stack Stator 1 Stage Gearhead
A	11.42 (290.1)	12.42 (315.5)	13.42 (340.9)

# R2M/R2G090 Rotary Motor/Gearmotor Dimensions

## R2M090 Dimensions

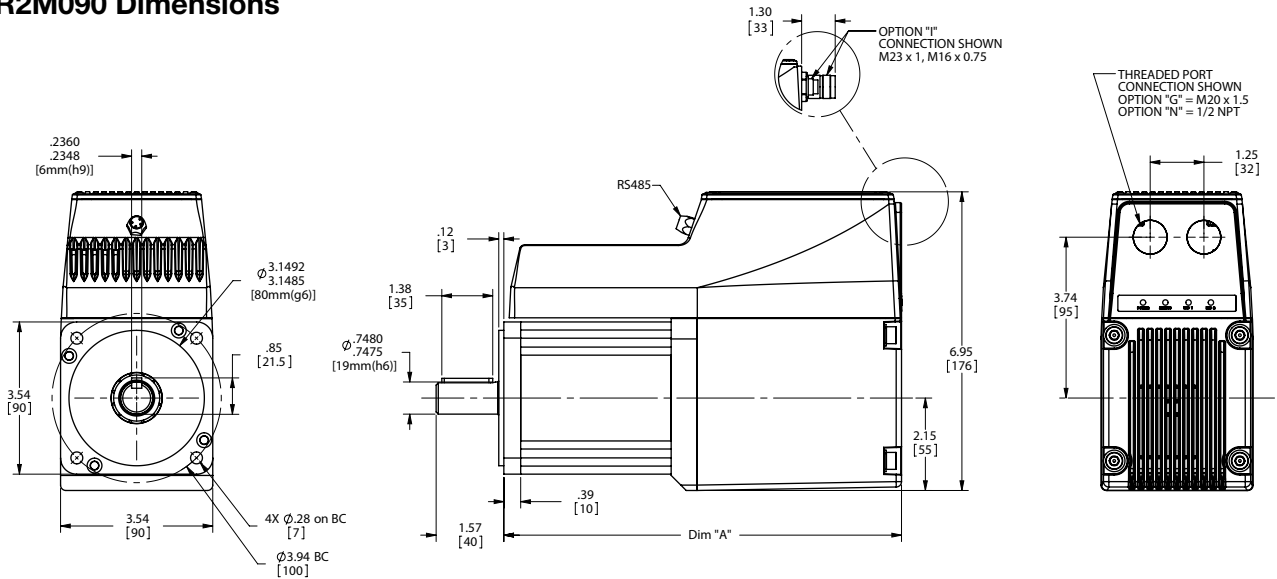

Without Brake Option		
DIM	2 Stack Stator	3 Stack Stator
A	10.25 (256.3)	11.25 (285.8)

With Brake Option		
DIM	2 Stack Stator	3 Stack Stator
A	11.6 (294.6)	12.6 (320.0)

## R2G090 Dimensions

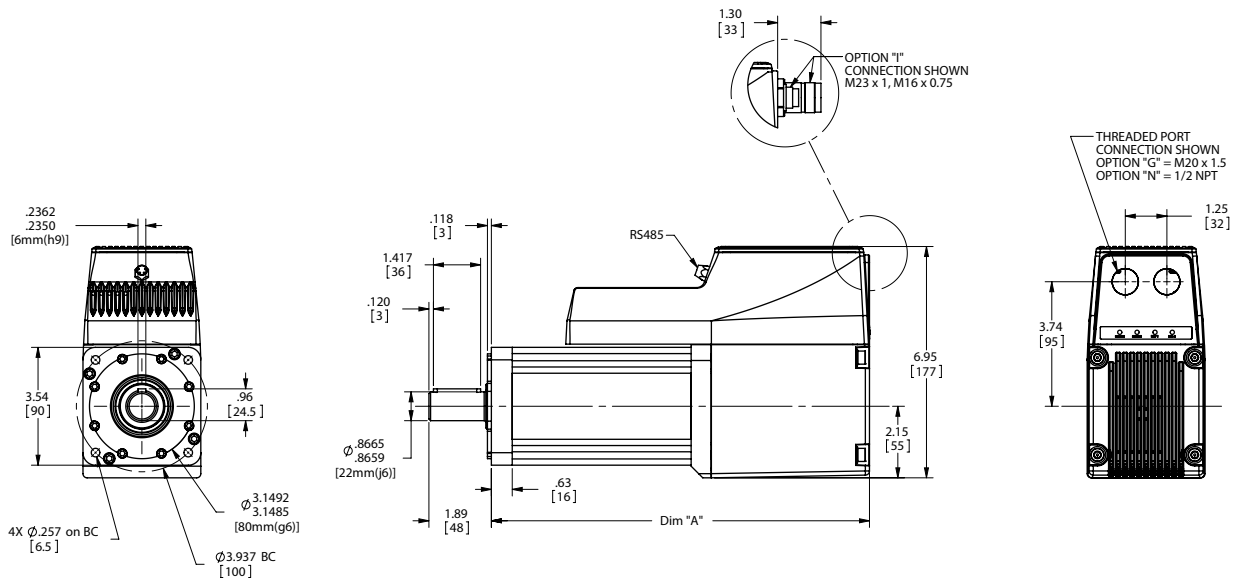

Without Brake Option		
DIM	2 Stack Stator 1 Stage Gearhead	3 Stack Stator 1 Stage Gearhead
A	12.36 (313.9)	13.36 (339.3)
DIM	2 Stack Stator 2 Stage Gearhead	3 Stack Stator 2 Stage Gearhead
A	13.63 (346.2)	14.63 (371.6)

With Brake Option		
DIM	2 Stack Stator 1 Stage Gearhead	3 Stack Stator 1 Stage Gearhead
A	13.67 (347.2)	14.67 (372.6)
DIM	2 Stack Stator 2 Stage Gearhead	3 Stack Stator 2 Stage Gearhead
A	14.94 (379.5)	15.94 (404.9)

# R2M/R2G115 Rotary Motor/Gearmotor Dimensions

## R2M115 Dimensions

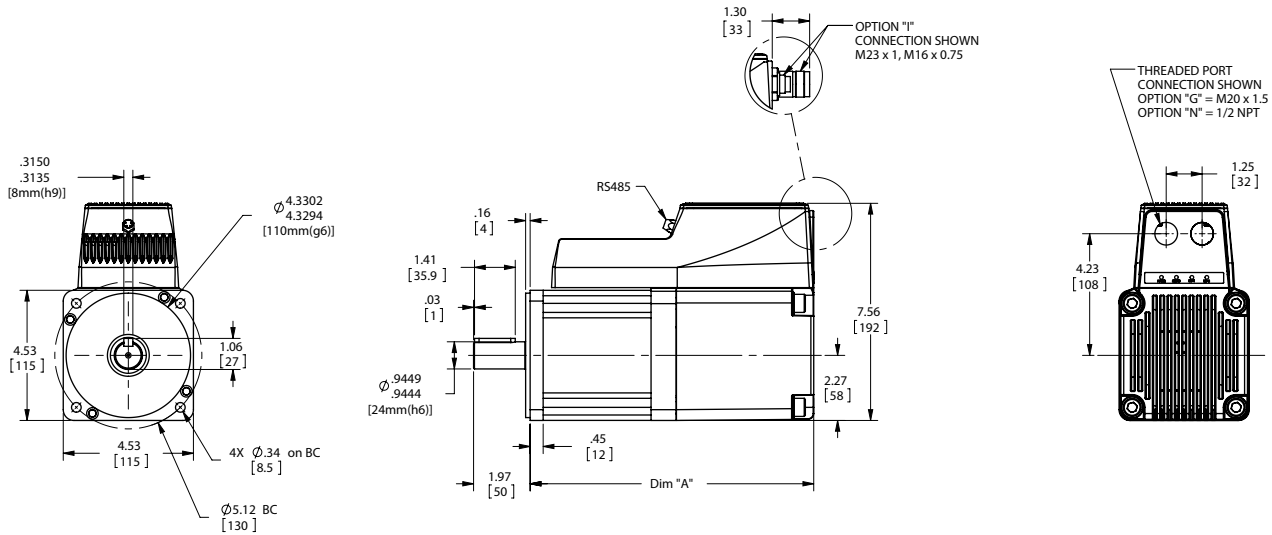

Without Brake Option		
DIM	1 Stack Stator	2 Stack Stator
A	9.87 (250.7)	11.87 (301.5)

With Brake Option		
DIM	1 Stack Stator	2 Stack Stator
A	11.60 (294.6)	13.60 (345.4)

## R2G115 Dimensions

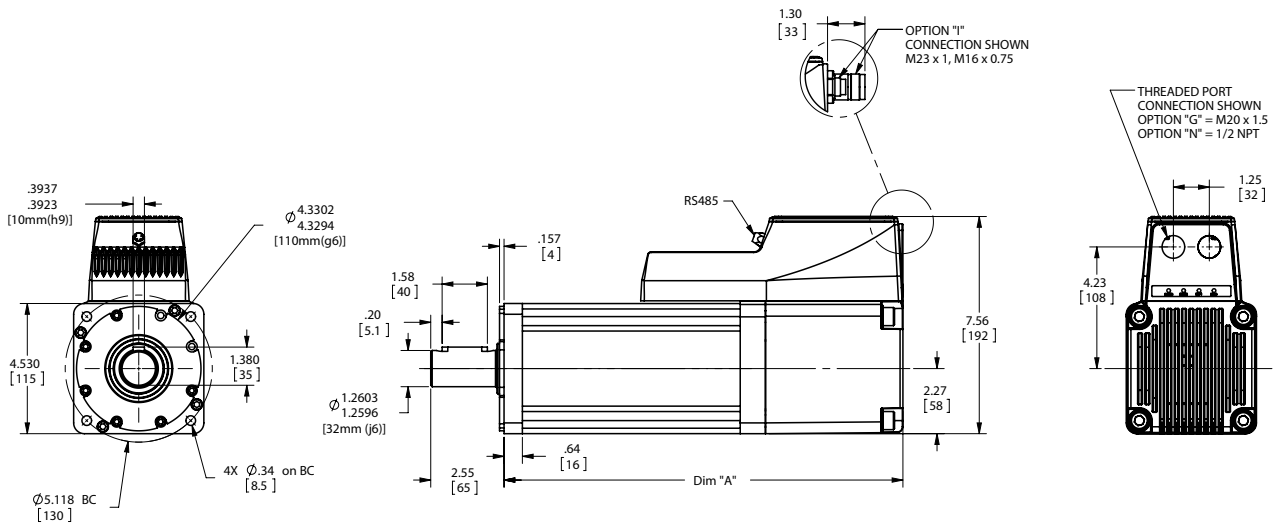

Without Brake Option		
DIM	1 Stack Stator 1 Stage Gearhead	2 Stack Stator 1 Stage Gearhead
A	13.88 (352.6)	15.88 (403.4)
DIM	1 Stack Stator 2 Stage Gearhead	2 Stack Stator 2 Stage Gearhead
A	15.49 (393.4)	17.49 (444.2)

With Brake Option		
DIM	1 Stack Stator 1 Stage Gearhead	2 Stack Stator 1 Stage Gearhead
A	15.43 (391.9)	17.43 (442.7)
DIM	1 Stack Stator 2 Stage Gearhead	2 Stack Stator 2 Stage Gearhead
A	17.04 (432.8)	19.04 (483.6)



# Linear Actuator Ordering Guide

## Tritex II AC T2M/X Linear Actuator Ordering Information

### T2M/X = Actuator Type

T2M = Tritex II Linear Actuator, standard mechanical capacity  
T2X = Tritex II Linear Actuator, high mechanical capacity

### BBB = Actuator Frame Size

075 = 75 mm  
090 = 90 mm  
115 = 115 mm

### CC = Stroke Length

03 = 3 inch (76 mm) (N/A T2M/X115)  
04 = 4 inch (102 mm) (T2M/X115 only)  
06 = 6 inch (150 mm)  
10 = 10 inch (254 mm)  
12 = 12 inch (305 mm)  
14 = 14 inch (356 mm) (T2M/X075)  
18 = 18 inch (457 mm)

### DD = Lead (linear travel per screw revolution)

01 = 0.1 inch (2.54 mm)  
02 = 0.2 inch (5.08 mm)  
05 = 0.5 inch (12.7 mm)  
08 = 0.75 inch (19.05 mm) (T2M/X115 only)<sup>5</sup>

### E = Connections

G = Standard Straight Threaded Port with Internal terminals, M20 x 1.5  
N = NPT Threaded Port via Adapter with Internal Terminals, 1/2" NPT  
I = Intercontec Style - Exlar std, M16/M23 Style Connector  
B = Embedded leads 3' std  
J = Embedded leads w/ "I" plug 3' std  
X = Custom Connectivity

### F = Mounting

B = Front & Rear Flange  
C = Rear Clevis  
D = Double Side Mount  
E = Extended Tie Rod

F = Front Flange  
G = Metric Rear Clevis  
J = Metric Side Mount  
K = Metric Double Side Mount  
M = Metric Extended Tie Rod  
Q = Metric Side Trunnion  
R = Rear Flange  
S = Side Mount  
T = Side Trunnion  
X = Special

### G = Rod End

A = Male Metric Thread<sup>1</sup>  
B = Female Metric Thread<sup>1</sup>  
F = Female US Standard Thread<sup>1</sup>  
L = Female Metric Thread SS<sup>1,2</sup>  
M = Male US Standard Thread<sup>1</sup>  
R = Male Metric Thread SS<sup>1,2</sup>  
V = Female US Standard Thread SS<sup>1,2</sup>  
W = Male, US Standard Thread SS<sup>1,2</sup>  
X = Special (please specify)

### HH = Feedback Type

HD = Analog Hall Device  
IE = Incremental Encoder, 8192 count resolution  
AF = Absolute Feedback

### III-II = Motor Stator, All 8 Pole

**T2M/X075 Stator Specifications**  
138-40 = 1 Stack, 230 VAC, 4000 rpm  
238-30 = 2 Stack, 230 VAC, 3000 rpm  
338-20 = 3 Stack, 230 VAC, 2000 rpm  
**T2M/X090 Stator Specifications**  
138-40 = 1 Stack, 230 VAC, 4000 rpm  
238-40 = 2 Stack, 230 VAC, 4000 rpm  
238-30 = 2 Stack, 230 VAC, 3000 rpm<sup>9</sup>  
**T2M/X115 Stator Specifications**  
138-30 = 1 Stack, 230 VAC, 3000 rpm  
238-20 = 2 Stack, 230 VAC, 2000 rpm  
238-15 = 2 Stack, 230 VAC, 1500 rpm<sup>9</sup> (N/A with 0.1" lead)

## T2M/XBBB-CCDD-EFG-HH-III-II-JJJ-KKK- (XX..XX - #####)

### JJJ = Voltage

230 = 115-230 VAC, single phase

### KKK = Option Board (only 1 selection allowed)

SIO = Standard I/O Interconnect  
IA4 = 4-20 mA Analog I/O  
COP = CANOpen w/M12 connector  
CON = CANOpen, without M12<sup>10</sup>  
EIP = SIO plus Ethernet/IP w/M12 connector  
EIN = SIO plus Ethernet/IP without M12 connector<sup>10</sup>  
PIO = SIO plus Profinet IO w/M12 connector  
PIN = SIO plus Profinet IO without M12 connector<sup>10</sup>  
TCP = SIO plus Modbus TCP w/M12 connector  
TCN = SIO plus Modbus TCP without M12 connector<sup>10</sup>

### X..XX = Travel and Housing Options (Multiples Possible)

#### Travel Options

AR = External Anti-rotate  
PF = Preloaded Follower<sup>3</sup>  
L1/2/3 = External Limit Switches<sup>7</sup>  
HW = Manual Drive, Handwheel with Interlock Switch (T2X only)  
SD = Manual Drive, Side Hex  
RB = Rear Brake  
PB = Protective Bellows (N/A with extended tie rod mounting option)  
SR = Splined Main Rod<sup>8,2</sup>  
XT = Special Travel Options

#### Housing Options

P5 = IP65 Sealed Housing (T2M only)  
HC = Type III Hard Coat Anodized<sup>4</sup>  
FG = White Epoxy Coating<sup>4</sup>  
XH = Special Housing Option.

### Special Motor Options

XL = Special Lubrication<sup>6</sup>  
XM = Special Motor Option

### ##### = Part No Designator for Specials

Optional 5 digit assigned PN to designate unique model numbers

#### NOTES:

1. Chrome-plated carbon steel. Threads not chrome-plated.
2. Consult Exlar when ordering splined stainless steel main rod.
3. The dynamic load rating of zero backlash, preloaded screws is 63% of the dynamic load rating of the std non-preloaded screws. The calculated travel life of a preloaded screw will be 25% of the calculated travel life of the same size and lead of a non-preloaded screw.
4. This housing option may indicate the need for special material main rods or mounting.
5. 0.75 lead not available above 12" stroke.
6. To achieve -40 operating temperature, specify -XL in the actuator model mask and define Mobilgrease 28 in order notes. Other special lubricants are also available.
7. Limit switch option requires AR option.
8. This option is not sealed and is not suitable for any environment in which contaminants come in contact with actuator and may enter the actuator.
9. N/A with 0.1" lead
10. Requires customer supplied Ethernet cable through I/O port for Class 1 Div 2 compliance only.

# Rotary Motor and Gearmotor Ordering Guide

## Tritex II AC R2M Motor or R2G Gearmotor Ordering Information

### R2M/G = Motor Type

R2M = Tritex II AC Rotary Motor  
R2G = Tritex II AC Rotary Gearmotor

### AAA = Frame Size

075 = 75 mm  
090 = 90 mm  
115 = 115 mm

### BBB = Gear Ratio

Blank = R2M

### Single Reduction Ratios

004 = 4:1  
005 = 5:1  
010 = 10:1

### Double Reduction Ratios (N/A on 75mm)

016 = 16:1 020 = 20:1  
025 = 25:1 040 = 40:1  
050 = 50:1 100 = 100:1

### C = Shaft Type

K = Keyed  
R = Smooth/Round  
X = Special Shaft

### D = Connections

G = Standard Straight Threaded Port with Internal Terminals, M20 x 1.5  
N = NPT Threaded Port with Internal Terminals, 1/2" NPT  
I = Intercontec style - Exlar Standard, M16/M23 Style Connector  
B = Embedded leads 3' std  
J = Embedded leads w/ "I" plug 3' std  
X = Custom Connectivity

### E = Coating Options

G = Exlar Standard  
H = Type III Hard Coat Anodized  
F = Smooth White Epoxy Coating  
X = Special or Custom

### F = Brake Option

S = No Brake, Standard  
B = Electric Brake, 24 VDC

### GG = Feedback Type

HD = Analog Hall Device  
IE = Incremental Encoder, 8192 Count Resolution  
AF = Absolute Feedback

## R2M/GAAA-BBB-CDEF-GG-HHH-HH-III-JJJ (XX...XX) - #####

### HHH-HH = Motor Stators

**R2M/G075 Stator Specifications**  
138-40 = 1 Stack, 230 VAC, 4000 rpm  
238-30 = 2 Stack, 230 VAC, 3000 rpm  
338-20 = 3 Stack, 230 VAC, 2000 rpm  
**R2M/G090 Stator Specifications**  
238-40 = 2 Stack, 230 VAC, 4000 rpm  
238-30 = 2 Stack, 230 VAC, 3000 rpm  
338-20 = 3 Stack, 230 VAC, 2000 rpm  
**R2M/G115 Stator Specifications**  
138-30 = 1 Stack, 230 VAC, 3000 rpm  
238-20 = 2 Stack, 230 VAC, 2000 rpm  
238-15 = 2 Stack, 230 VAC, 1500 rpm

### III = Voltage

230 = 115-230 VAC, Single Phase

### JJJ = Option Board

SIO = Standard I/O Interconnect  
IA4 = 4-20 mA Analog I/O  
COP = CANOpen w/M12 connector  
CON = CANOpen, without M12 connector<sup>1</sup>  
EIP = SIO plus Ethernet/IP w/M12 connector  
EIN = SIO plus Ethernet/IP without M12 connector<sup>1</sup>  
PIO = SIO plus Profinet IO w/M12 connector

PIN = SIO plus Profinet IO without M12 connector<sup>1</sup>  
TCP = SIO plus Modbus TCP w/M12 connector  
TCN = SIO plus Modbus TCP without M12 connector<sup>1</sup>

### XX = Special Options (multiples possible)

HW = Manual Drive, Handwheel with Interlock Switch  
SD = Manual Drive, Side Hex  
XH = Special Housing Options  
XM = Special Motor Options  
XL = Special Lubrication<sup>2</sup>

### ##### = Part No Designator for Specials

Optional 5 digit assigned PN to designate unique model no.

#### NOTES:

1. Requires customer supplied Ethernet cable through I/O port for Class 1 Div 2 compliance only.
2. To achieve -40° C operating temperature, specify -XL in the actuator model mask and define Mobilgrease 28 in order notes. Other special lubricants are also available.

# Cables/Accessories Ordering Guide

Tritex II AC Series Cable & Accessories		Part No.
<b>“G” Connection Accessories</b>		
Nickel plated cable gland- M20 x 1.5 - CE shielding- 2 required		GLD-T2M20 x 1.5
Power cable prepared on one end for use with GLD-T2M20 x 1.5 xxx = Length in ft, Standard lengths 015, 025, 050, 075, 100		CBL-T2IPC-RAW-xxx
I/O cable prepared on one end for use with GLD-T2M20 x 1.5 xxx = Length in ft, Standard lengths 015, 025, 050, 075, 100		CBL-T210C-RAW-xxx
<b>“N” Connection Accessories</b>		
M20 x 1.5 to 1/2" NPT threaded hole adapter for use with conduit		ADAPT-M20-NPT1/2
<b>“I” Connection</b>		
Power cable with M23 6 pin xxx = Length in feet, std lengths 015, 025, 050, 075, 100		CBL-T2IPC-SMI-xxx
I/O cable (75 mm) with M23 19 pin xxx = Length in feet, std lengths 015, 025, 050, 075, 100		CBL-TT10C-SMI-xxx
I/O cable (90 & 115 mm) with M16 19 pin xxx = Length in feet, std lengths 015, 025, 050, 075, 100		CBL-T210C-SMI-xxx
<b>Communications Accessories - Tritex uses a 4 pin M8 RS485 communications connector</b>		
Recommended PC to Tritex communications cable-USB/RS485 to M8 connector - xxx = Length in feet, 006 or 015 only		CBL-T2USB485-M8-xxx
<b>Multi-Drop RS485 Accessories</b>		
RS485 splitter - M8 Pin plug to double M8 Socket receptacle		TT485SP
Multidrop Communications Cable M8 to M8 for use with TT485SP/RS485 splitter - xxx = Length in feet, 006 or 015 only		CBL-TTDAS-xxx
<b>Multi-Purpose Communications Accessories for long runs, requires terminal block interconnections</b>		
USB to RS485 convertor/cable - USB to RS485 flying leads - xxx = Length in feet, 006 or 015 only		CBL-T2USB485-xxx
Communications cable M8 to flying leads cable xxx = Length in feet, standard lengths 015, 025, 050, 075, 100		CBL-TTCOM-xxx
<b>Option Board Cables and Accessories</b>		
CAN Male to Female Molded 3 ft. cable		CBL-TTCAN-SMF-003
CAN Male to Female Molded 6 ft. cable		CBL-TTCAN-SMF-006
CAN Cable, no connectors – per foot		CBL-TTCAN-S
CAN Male connector, field wireable		CON-TTCAN-M
CAN Female connector, field wireable		CON-TTCAN-F
CAN Splitter		CON-TTCAN-SP
EIP, PIO and TCP option Ethernet cable - M12 to RJ45 cable xxx = Length in feet, std lengths 015, 025, 050, 075, 100. For EIN, PIN & TCN see note 11, page 22.		CBL-T2ETH-R45-xxx
<b>Electrical Accessories</b>		
Dynamic Braking Resistor - 100W470hm		T2BR1
Replacement -AF Battery - used for absolute feedback option		T2BAT1
Replacement Normally Closed External Limit Switch (Turck Part number BIM-UNT-RP6X)		43404
Replacement Normally Open External Limit Switch (Turck Part number BIM-UNT-AP6X)		43403
<b>Mechanical Accessories</b>		
Clevis Pin for T2M/X090 male “M” rod end 1/2-20 thread		CP050
Clevis Pin for T2M/X115 male “M” rod end 3/4-16 thread		CP075
Spherical Rod Eye for T2M/X090 male “M” rod end 1/2-20 thread		SRM050
Spherical Rod Eye for T2M/X115 male “M” rod end 3/4-16 thread		SRM075
Rod Eye for T2M/X090 male “M” rod end 1/2-20 thread		REI050
Rod Eye for T2M/X115 male “M” rod end 3/4-16 thread		RE075
Rod Clevis for T2M/X090 male “M” rod end 1/2-20 thread		RCI050
Rod Clevis for T2M/X115 male “M” rod end 3/4-16 thread		RC075
Jam Nut for T2M/X090 male rod end, 1/2 - 20		JAM1/2-20-SS
Jam Nut for T2M/X115 male rod end, 3/4-16		JAM3/4-16-SS

## Options/Accessories



### CBL-T2USB485-M8-xxx

Our recommended communications cable. No special drivers or setup required for use with MS Windows™.



### CBL-T2USB485-xxx

Use for terminal connections with CBL-TTCOM for long cable runs. No special drivers or setup required for use with MS Windows™.



### CBL-TTCOM-xxx

Use with CBL-T2USB485-xxx for long cable runs.



### CBL-TTDAS-xxx

For use with TT485SP for multi-drop applications.

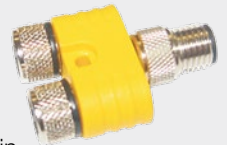

### TT485SP

RS485 communications splitter. Use to daisy-chain multiple Tritex actuators.



### CON-TTCAN-SP

CAN splitter



### CON-TTCAN-M

M12 Field wireable connector

# Tritex II DC Linear & Rotary Actuators

## No Compromises on Power, Performance or Reliability

With forces to approximately 950 lbs (4kN) continuous and 1,300 lbf peak (6 kN), and speeds to 33 in/sec (800 mm/sec), the DC Tritex II linear actuators also offer a benefit that no other integrated product offers—POWER! No longer are you limited to trivial amounts of force, or speeds so slow that many motion applications are not possible. And the new Tritex II with DC power electronics operates with maximum reliability over a broad range of ambient temperatures: -40°C to +65°C. The DC powered Tritex II actuators contain a 750 W servo amplifier and a very capable motion controller. With standard features such as analog following for position, compound moves, move chaining and individual force/torque control for each move, the Tritex II Series is the ideal solution for most motion applications.



Tritex II Linear DC Actuator

# TRITEX

## Tritex II Models

- TDM standard mechanical capacity actuator, 60 and 75 mm
- TDX high mechanical capacity actuator, 60 and 75 mm
- RDM rotary motor, 60, 75 and 90 mm
- RDG rotary gearmotor, 60, 75 and 90 mm

## Power Requirements

- DC Power 12-48 VDC nominal
- Connections for external braking resistor

## Feedback Types

- Analog Hall with 1000 count resolution
- Incremental encoder with 8192 count resolution
- Absolute Feedback (analog hall with multi-turn, battery backup)

## Connectivity

- Internal terminals accessible through removable cover (75 and 90 mm only)
- Threaded ports for cable glands (75 and 90 mm only)
- Optional connectors - M23 Power - M23 I/O
- M8 connector for RS485
- M12 connector for EtherNet options
- Custom connection options
- Embedded leads



Tritex II rotary motor with connectors shown left and Tritex II linear actuator with customer-supplied cable glands ports shown above.

## Communications & I/O

### Digital Inputs:

9 to 30 VDC Opto-isolated

### Digital outputs:

30 VDC maximum

100 mA continuous output

Isolated

Short circuit & over temperature protected

### Analog Input DC:

0-10V or +/-10V

0-10V mode, 12 bit resolution

+/-10V mode, 13 bit resolution

assignable to Position, Velocity, Torque or Velocity override command

### Analog Output DC:

0-10V

11 bit resolution

### IA 4 option

4-20 mA input

16 bit resolution

Isolated

Assignable to Position, Velocity, Torque or Velocity override command

4-20 mA output

12 bit resolution

Assignable to Position, Velocity, Current, Temperature etc

### Standard Communications:

- 1 RS485 port, Modbus RTU, opto-isolated for programming, controlling and monitoring

## Tritex II DC I/O

	60/75/90 mm frame with SIO, EIP, PIO, TCP	60/75/90 mm frame with IA4	60/75/90 mm frame with CAN
Isolated digital inputs	8	4	4
Isolated digital outputs	4	3	3
Analog input, non isolated	1	0	0
Analog output, non isolated	1	0	0
Isolated 4-20ma input	0	1	0
Isolated 4-20ma output	0	1	0

The IO count and type vary with actuator mode and option module selected.

All models include isolated digital IO, and an isolated RS485 communication port with using Modbus RTU protocol.

## Manual Override Options

(Available on 75 & 90 mm linear and 75 & 90 mm rotary only, rotary not shown)

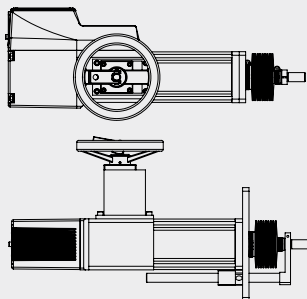

### Handwheel

This option gives you a manual engagement switch that can be used to disable the power to the actuator for manual operation without any external tools.

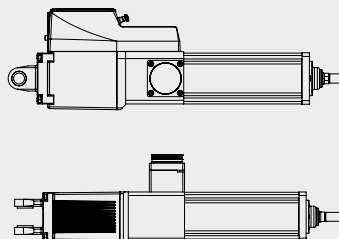

### Side Drive

This option allows for emergency operation in a power down condition using a standard socket wrench.



# Travel Life and Temperature Ratings

## Travel Life

### TDM/TDX Lifetime Curves

The  $L_{10}$  expected life of a roller screw linear actuator is expressed as the linear travel distance that 90% of properly maintained roller screws manufactured are expected to meet or exceed. For higher than 90% reliability, the result should be multiplied by the following factors: 95% x 0.62; 96% x 0.53; 97% x 0.44; 98% x 0.33; 99% x 0.21. This is not a guarantee and these charts should be used for estimation purposes only.

The underlying formula that defines this value is:

Travel life in millions of inches, where: 
$$L_{10} = \left(\frac{C}{F}\right)^3 \times S =$$

**C** = Dynamic load rating (lbf)

**F** = Cubic mean applied load (lbf)

**S** = Roller screws lead (inches)

*All curves represent properly lubricated and maintained actuators.*

### Dynamic Load Rating

Model	lb (N)	Model	lb (N)
TDM060-xx01	1568 (6970)	TDX060-xx01	2075 (9320)
TDM060-xx02	1219 (5422)	TDX060-xx02	1540 (6850)
TDM060-xx04	738 (3283)	TDX060-xx04	1230 (5471)
TDM075-xx01	3310 (14724)	TDX075-xx01	5516 (24536)
TDM075-xx02	3570 (15880)	TDX075-xx02	5800 (25798)
TDM075-xx05	3016 (13416)	TDX075-xx05	4900 (21795)

TDM/X060 Estimated  $L_{10}$  Travel Life

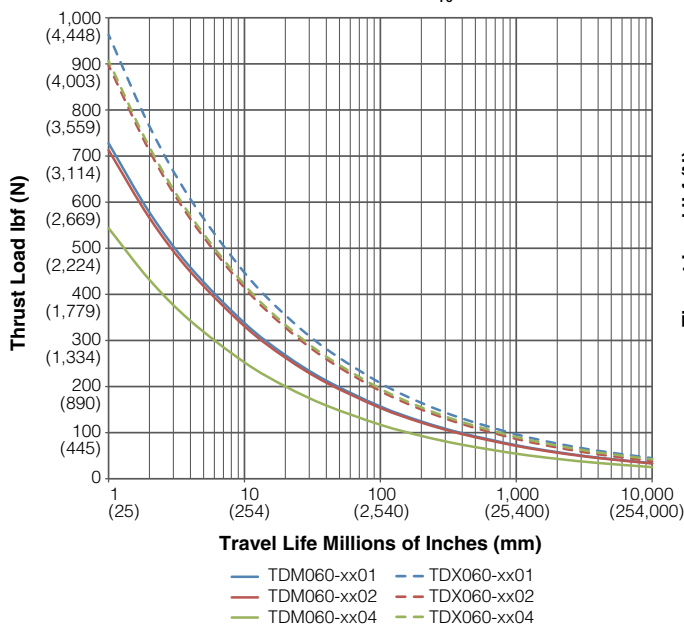

TDM/X075 Estimated  $L_{10}$  Travel Life

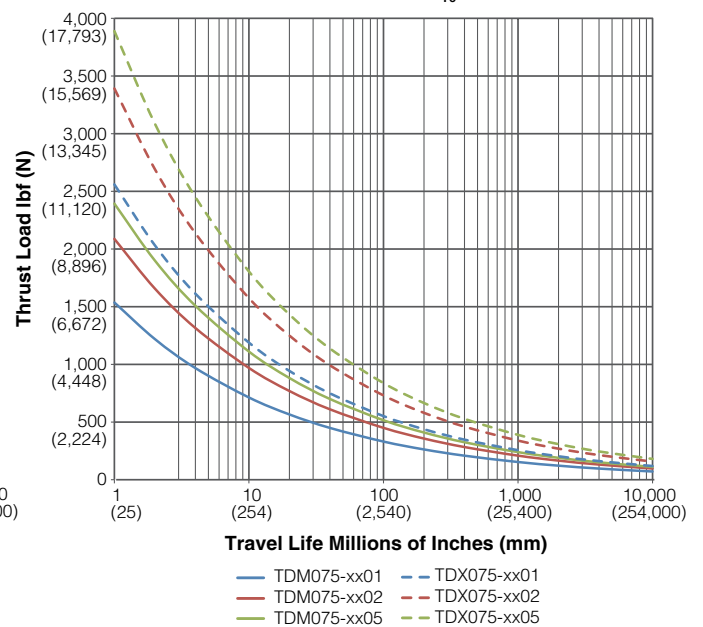

## Extended Temperature De-Rating Curve

The speed/torque curves are based on 40° C ambient conditions. The actuators may be operated at ambient temperatures up to 65° C. Use the curve shown right for continuous torque/force deratings above 40° C.

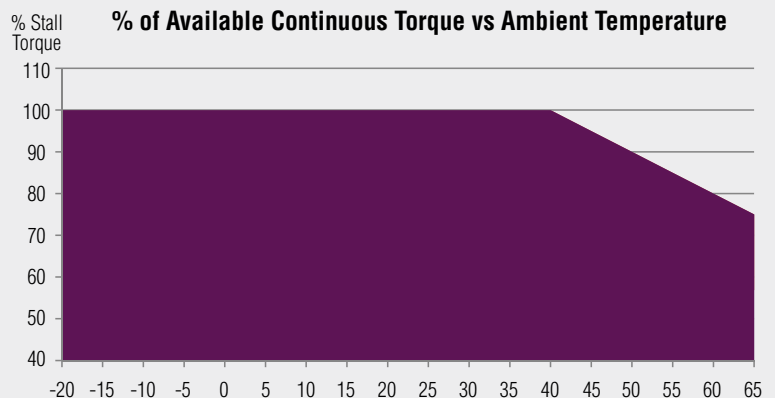



# TDM/X060 Linear Actuator Speed vs. Force Curves

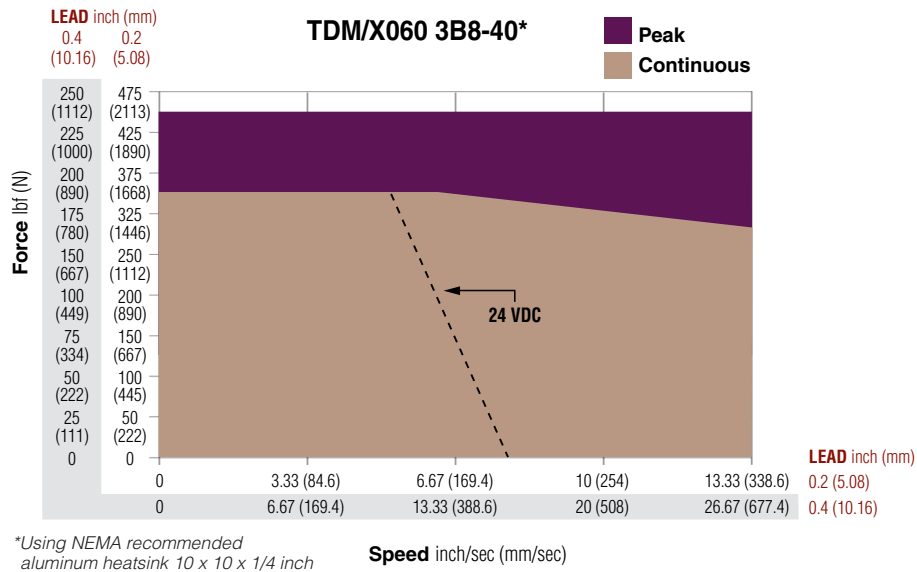
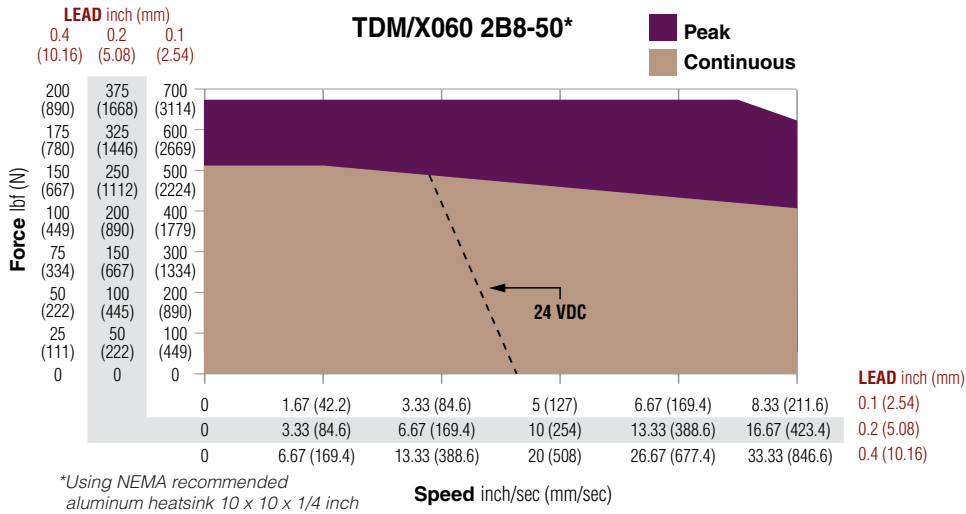
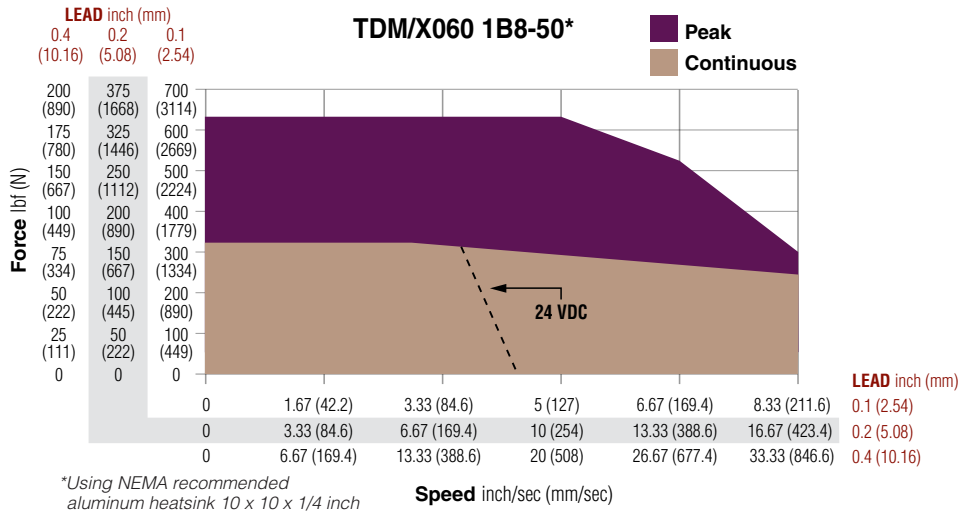

# TDM/X075 Linear Actuator Speed vs. Force Curves

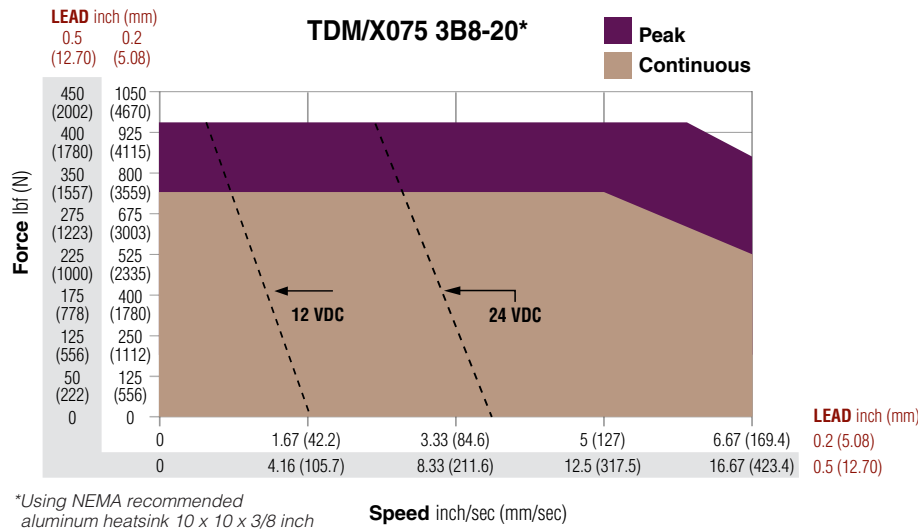
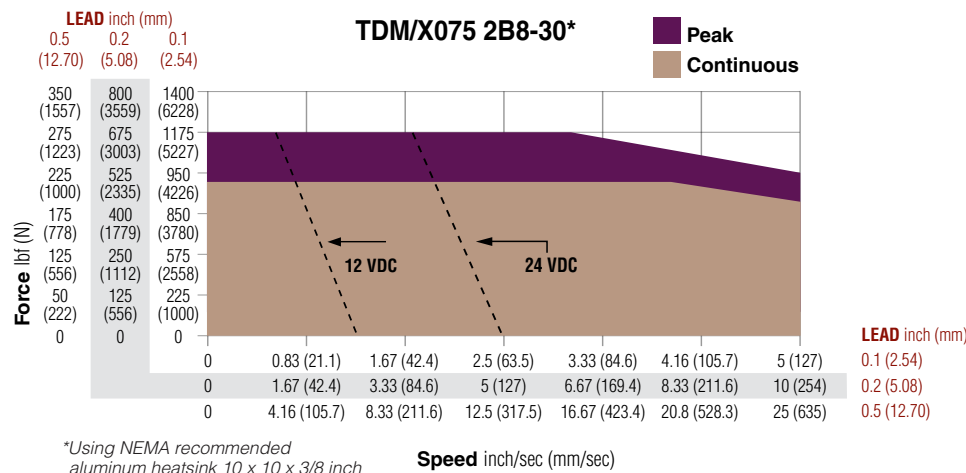
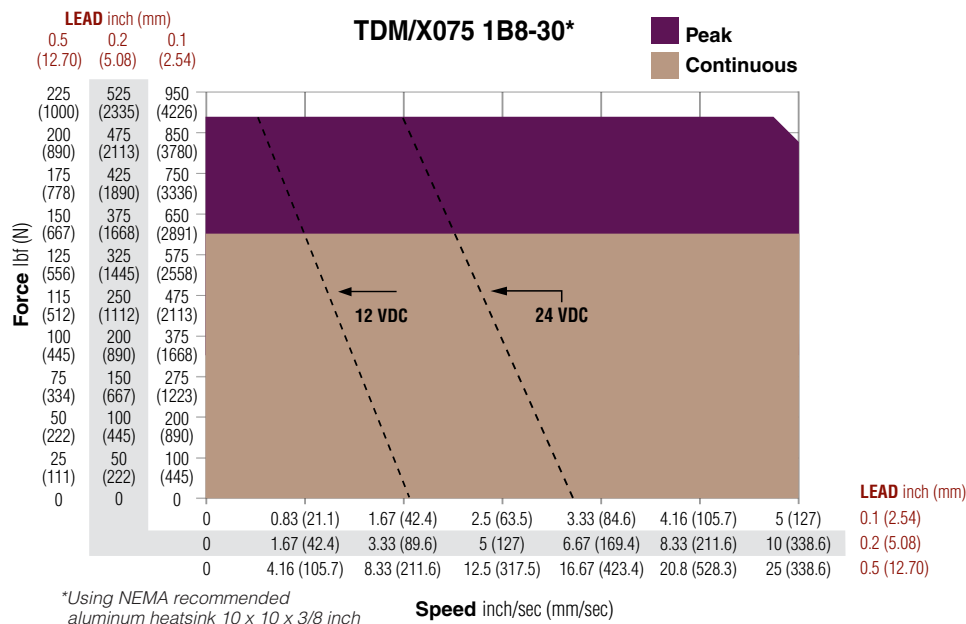

# RDM060/RDM075/RDM090 Rotary Actuator Speed vs. Torque Curves

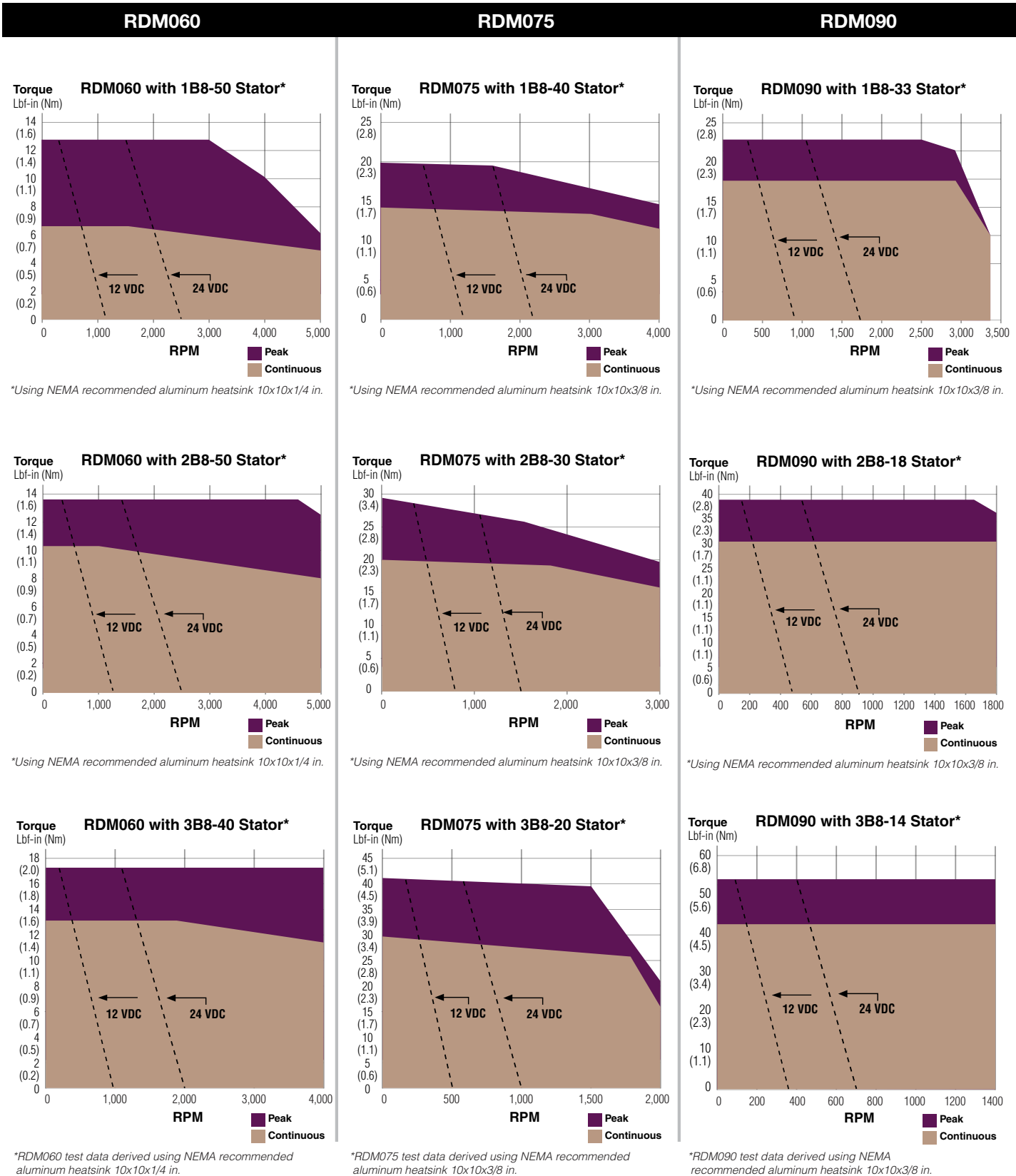

For RDG gearmotors, multiply torque by ratio and efficiency. Divide speed by gear ratio.

# TDM/X Linear Actuator Performance Specifications

TDM/X060 Linear Actuator Performance Specifications					
<b>Backlash</b>		in (mm)		0.004 (0.10)	
<b>Lead Accuracy</b>		in/ft (mm/300 mm)		.001 (.025)	
<b>Maximum Radial Load</b>		lb (N)		15 (67)	
<b>Environmental Rating: Std</b>				IP54 / IP65	
			<b>Stator</b>	<b>1 Stack 1B8-50</b>	<b>2 Stack 2B8-50</b>
<b>Lead</b>		<b>RPM @ 48 VDC</b>	<b>5000</b>	<b>5000</b>	<b>4000</b>
<b>0.1</b>	<b>Continuous Stall Force</b>	lbf (N)	339 (1508)	528 (2349)	N/A
	<b>Peak Stall Force</b>	lbf (N)	641 (2851)	666 (2963)	N/A
	<b>Max Speed @ 48 VDC</b>	in/sec (mm/sec)	8.33 (211.6)	8.33 (211.6)	N/A
<b>0.2</b>	<b>Continuous Stall Force</b>	lbf (N)	180 (801)	280 (1246)	347 (1544)
	<b>Peak Stall Force</b>	lbf (N)	340 (1512)	354 (1575)	454 (2019)
	<b>Max Speed @ 48 VDC</b>	in/sec (mm/sec)	16.67 (423.4)	16.67 (423.4)	13.33 (338.6)
<b>0.4</b>	<b>Continuous Stall Force</b>	lbf (N)	95 (423)	148 (658)	184 (818)
	<b>Peak Stall Force</b>	lbf (N)	180 (801)	187 (832)	240 (1068)
	<b>Max Speed @ 48 VDC</b>	in/sec (mm/sec)	33.33 (846.6)	33.33 (846.6)	26.67 (677.4)
<b>Drive Current @ Continuous Stall Force</b>		Amps	14.75	21.5	21.5
<b>Available Stroke Lengths</b>		in (mm)	3 (75), 6 (150), 10 (254), 12 (300)		
<b>Approximate Weight</b>		lb (kg)	4 lbs – 3 in stroke, 1 stack, add 1 lb per inch of stroke, add 3 lbs per stack, add 3 lbs for brake. (1.8 kg – 75 mm stroke, 1 stack, add 0.5 kg per 25 mm of stroke, add 1.4 kg per stack, add 1.4 kg for brake.)		
<b>Operating Temperature Range**</b>			-20 to 65° C (-40° C available, consult Exlar)		
<b>Maximum Continuous Power Supply Current*</b>		Amps	11	15	15

\*Power supply current is based on software current limit, not thermal limit. Consideration for peak current should also be considered when sizing power supplies.

\*\*Rating based on 40° C ambient conditions.

TDM/X075 Linear Actuator Performance Specifications					
<b>Backlash</b>		in (mm)		0.004 (0.10)	
<b>Lead Accuracy</b>		in/ft (mm/300 mm)		.001 (.025)	
<b>Maximum Radial Load</b>		lb (N)		15 (67)	
<b>Environmental Rating: Std</b>				IP54 / IP65	
			<b>Stator</b>	<b>1 Stack 1B8-30</b>	<b>2 Stack 2B8-30</b>
<b>Lead</b>		<b>RPM @ 48 VDC</b>	<b>3000</b>	<b>3000</b>	<b>2000</b>
<b>0.1</b>	<b>Continuous Stall Force</b>	lbf (N)	613 (2727)	872 (3879)	N/A
	<b>Peak Stall Force</b>	lbf (N)	884 (3932)	1190 (5293)	N/A
	<b>Max Speed @ 48 VDC</b>	in/sec (mm/sec)	5.00 (127)	5.00 (127)	N/A
<b>0.2</b>	<b>Continuous Stall Force</b>	lbf (N)	347 (1544)	494 (2197)	774 (3443)
	<b>Peak Stall Force</b>	lbf (N)	501 (2229)	674 (2998)	1095 (4871)
	<b>Max Speed @ 48 VDC</b>	in/sec (mm/sec)	10.00 (254)	10.00 (254)	6.67 (169.4)
<b>0.5</b>	<b>Continuous Stall Force</b>	lbf (N)	147 (654)	209 (930)	328 (1459)
	<b>Peak Stall Force</b>	lbf (N)	212 (943)	286 (1272)	464 (2064)
	<b>Max Speed @ 48 VDC</b>	in/sec (mm/sec)	25.00 (635)	25.00 (635)	16.67 (423.4)
<b>Drive Current @ Continuous Stall Force</b>		Amps	18.5	22.5	22.5
<b>Available Stroke Lengths</b>		in (mm)	3 (75), 6 (150), 10 (254), 12 (300), 14 (355), 18 (450)		
<b>Approximate Weight</b>		lb (kg)	11 lbs – 3 in stroke, add 1 lb per inch of stroke, add 3 lbs per stack, add 3 lbs for brake (5 kg – 75 mm stroke, 1 stack, add 0.5 kg per 25 mm of stroke, add 1.4 kg per stack, add 1.4 kg for brake.)		
<b>Operating Temperature Range**</b>			-20 to 65° C (-40° C available, consult Exlar)		
<b>Maximum Continuous Power Supply Current*</b>		Amps	15	18	18

\*Power supply current is based on software current limit, not thermal limit. Consideration for peak current should also be considered when sizing power supplies.

\*\*Rating based on 40° C ambient conditions.

# RDM/RDG060 Rotary Motor/Gearmotor Performance Specifications

## RDM060 Rotary Motor Torque and Speed Ratings

	Stator	1 Stack 1B8-50	2 Stack 2B8-50	3 Stack 3B8-40
	RPM at 48 VDC	5000	5000	4000
<b>Continuous Stall Torque</b>	lbf-in (Nm)	6.8 (0.76)	10.5 (1.18)	13 (1.47)
<b>Peak Stall Torque</b>	lbf-in (Nm)	12.8 (1.44)	13.3 (1.5)	17 (1.92)
<b>Drive Current @ Continuous Stall Force</b>	Amps	14.8	21.5	21.5
<b>Operating Temperature Range**</b>	-20 to 65° C (-40°C available, consult Exlar)			
<b>Maximum Continuous Power Supply Current*</b>	Amps	8	11	13

\*Power supply current is based on software current limit, not thermal limit. Consideration for peak current should also be considered when sizing power supplies. For output torque of RDG gearmotors, multiply by ratio and efficiency. Please note maximum allowable output torques found at bottom of page.

\*\*Ratings based on 40° C ambient conditions.

## RDM/RDG060 Inertia

	Stator	1 Stack	2 Stack	3 Stack
<b>RDM Motor Armature Inertia (+/-5%)</b>	lb-in-sec <sup>2</sup> (kg-cm <sup>2</sup> )	0.000237 (0.268)	0.000413 (0.466)	0.000589 (0.665)
<b>RDG Gearmotor Armature Inertia*</b>	lb-in-sec <sup>2</sup> (kg-cm <sup>2</sup> )	0.000226 (0.255)	0.000401 (0.453)	0.000576 (0.651)

\*Add armature inertia to gearing inertia for total inertia.

## Radial Load and Bearing Life

RPM	50	100	250	500	1000	3000
<b>RDM060</b> lbf (N)	250 (1112)	198 (881)	148 (658)	116 (516)	92 (409)	64 (285)
<b>RDG060</b> lbf (N)	189 (841)	150 (667)	110 (489)	88 (391)	70 (311)	48 (214)

Side load ratings shown above are for 10,000 hour bearing life at 25mm from motor face at given rpm.

## RDG060 Gearmotor Mechanical Ratings

Model	Ratio	Maximum Allowable Output Torque-Set by User lbf-in (Nm)	Output Torque at Motor Speed for 10,000 Hour Life		
			1000 RPM lbf-in (Nm)	3000 RPM lbf-in (Nm)	5000 RPM lbf-in (Nm)
RDG060-004	4:1	603 (68.1)	144 (16.2)	104 (11.7)	88 (9.9)
RDG060-005	5:1	522 (58.9)	170 (19.2)	125 (14.1)	105 (11.9)
RDG060-010	10:1	327 (36.9)	200 (22.6)	140 (15.8)	120 (13.6)
RDG060-016	16:1	603 (68.1)	224 (25.3)	160 (18.1)	136 (15.4)
RDG060-020	20:1	603 (68.1)	240 (27.1)	170 (19.2)	146 (16.5)
RDG060-025	25:1	522 (58.9)	275 (31.1)	200 (22.6)	180 (20.3)
RDG060-040	40:1	603 (68.1)	288 (32.5)	208 (23.5)	180 (20.3)
RDG060-050	50:1	522 (58.9)	340 (38.4)	245 (27.7)	210 (23.7)
RDG060-100	100:1	327 (36.9)	320 (36.1)	280 (31.6)	240 (27.1)

Two torque ratings for the RDG gearmotors are given in the table above. The left hand columns give the maximum (peak) allowable output torque for the indicated ratios of each size RDG gearmotor. This is not the rated output torque of the motor multiplied by the ratio of the reducer.

It is possible to select a configuration of the motor selection and gear ratio such that the rated motor torque, multiplied by the gear ratio exceeds these ratings. It is the responsibility of the user to ensure that the settings of the system do not allow these values to be exceeded.

The right hand columns give the output torque at the indicated speed which will result in 10,000 hour life (L10). The setup of the system will determine the actual output torque and speed.

## RDG060 Gearing Reflected Inertia

Single Reduction			Double Reduction		
Gear Stages	lbf-in-sec <sup>2</sup>	(kg-cm <sup>2</sup> )	Gear Stages	lbf-in-sec <sup>2</sup>	(kg-cm <sup>2</sup> )
4:1	0.0000132	(0.149)	16:1	0.0000121	(0.0137)
5:1	0.0000087	(0.00984)	20:1, 25:1	0.0000080	(0.00906)
10:1	0.0000023	(0.00261)	40:1, 50:1, 100:1	0.0000021	(0.00242)

## Backlash and Efficiency

	Single Reduction	Double Reduction
<b>Backlash at 1% Rated Torque</b>	10 Arc min	13 Arc min
<b>Efficiency</b>	91%	86%

## RDM060 Motor and RDG060 Gearmotor Weights

	RDM060 without Gears	RDG060 with 1 Stage Gearing	RDG060 with 2 Stage Gearing	Added Weight for Brake
<b>1 Stack Stator</b>	lb (kg)	3.0 (1.4)	7.5 (3.4)	.44 (.2)
<b>2 Stack Stator</b>	lb (kg)	4.1 (1.9)	8.6 (3.9)	
<b>3 Stack Stator</b>	lb (kg)	5.2 (2.4)	9.7 (4.4)	

# RDM/RDG075 Rotary Motor/Gearmotor Performance Specifications

## RDM075 Rotary Motor Torque and Speed Ratings

	Stator	1 Stack 1B8-40	2 Stack 2B8-30	3 Stack 3B8-20
	RPM at 48 VDC	4000	3000	2000
Continuous Stall Torque	lbf-in (Nm)	13 (1.46)	18.5 (2.09)	29 (3.28)
Peak Stall Torque	lbf-in (Nm)	18.9 (2.08)	28 (3.16)	41 (4.63)
Drive Current @ Continuous Stall Force	Amps	22	22	22
Operating Temperature Range**	-20 to 65° C (-40°C available, consult Exlar)			
Maximum Continuous Power Supply Current*	Amps	15	18	18

\*Power supply current is based on software current limit, not thermal limit. Consideration for peak current should also be considered when sizing power supplies. For output torque of RDG gearmotors, multiply by ratio and efficiency. Please note maximum allowable output torques shown below.

\*\*Ratings based on 40° C ambient conditions.

## RDM/RDG075 Inertia

	Stator	1 Stack	2 Stack	3 Stack
RDM Motor Armature Inertia (+/-5%)	lb-in-sec <sup>2</sup> (kg-cm <sup>2</sup> )	0.000545 (0.6158)	0.000973 (1.0996)	0.001401 (1.5834)
RDG Gearmotor Armature Inertia* (+/-5%)	lb-in-sec <sup>2</sup> (kg-cm <sup>2</sup> )	0.000660 (0.7450)	0.001068 (1.2057)	0.001494 (1.6868)

\*Add armature inertia to gearing inertia for total inertia.

## Radial Load and Bearing Life

	RPM	50	100	250	500	1000	3000
RDM075 lbf (N)	278 (1237)	220 (979)	162 (721)	129 (574)	102 (454)	71 (316)	
RDG075 lbf (N)	343 (1526)	272 (1210)	200 (890)	159 (707)	126 (560)	88 (391)	

Side load ratings shown above are for 10,000 hour bearing life at 25mm from motor face at given rpm.

## RDG075 Gearmotor Mechanical Ratings

Model	Ratio	Maximum Allowable Output Torque-Set by User lbf-in (Nm)	Output Torque at Motor Speed for 10,000 Hour Life		
			1000 RPM lbf-in (Nm)	2500 RPM lbf-in (Nm)	4000 RPM lbf-in (Nm)
RDG075-004	4:1	1618 (182.8)	384 (43.4)	292 (32.9)	254 (28.7)
RDG075-005	5:1	1446 (163.4)	395 (44.6)	300 (33.9)	260 (29.4)
RDG075-010	10:1	700 (79.1)	449 (50.7)	341 (38.5)	296 (33.4)

Two torque ratings for the RDG gearmotors are given in the table above. The left hand columns give the maximum (peak) allowable output torque for the indicated ratios of each size RDG gearmotor. This is not the rated output torque of the motor multiplied by the ratio of the reducer.

It is possible to select a configuration of the motor selection and gear ratio such that the rated motor torque, multiplied by the gear ratio exceeds these ratings. It is the responsibility of the user to ensure that the settings of the system do not allow these values to be exceeded.

The right hand columns give the output torque at the indicated speed which will result in 10,000 hour life (L10). The setup of the system will determine the actual output torque and speed.

## RDG075 Gearing Reflected Inertia

Single Reduction (+/-5%)		
Gear Stages	lbf-in-sec <sup>2</sup>	(kg-cm <sup>2</sup> )
4:1	0.000095	(0.107)
5:1	0.000062	(0.069)
10:1	0.000117	(0.019)

## Backlash and Efficiency

Single Reduction	
Backlash at 1% Rated Torque	10 Arc min
Efficiency	91%

## RDM075 Motor and RDG075 Gearmotor Weights

	RDM075 without Gears	RDG075 with 1 Stage Gearing	Added Weight for Brake
1 Stack Stator lb (kg)	7.4 (3.4)	9.8 (4.4)	0.8 (0.4)
2 Stack Stator lb (kg)	9.2 (4.2)	11.6 (5.3)	
3 Stack Stator lb (kg)	11 (4.9)	13.4 (6.1)	



# RDM/RDG090 Rotary Motor/Gearmotor Performance Specifications

RDM090 Rotary Motor Torque and Speed Ratings				
	Stator	1 Stack 1B8-33	2 Stack 2B8-18	3 Stack 3B8-14
	RPM at 48 VDC	3300	1800	1400
Continuous Stall Torque	lbf-in (Nm)	17 (1.92)	28 (3.16)	41 (4.63)
Peak Stall Torque	lbf-in (Nm)	21.8 (2.46)	36 (4.07)	52.8 (5.97)
Drive Current @ Continuous Stall Force	Amps	22	22	22
Operating Temperature Range**	-20 to 65° C (-40°C available, consult Exlar)			
Maximum Continuous Power Supply Current*	Amps	18	18	18

\*Power supply current is based on software current limit, not thermal limit. Consideration for peak current should also be considered when sizing power supplies.

For output torque of RDG gearmotors, multiply by ratio and efficiency. Please note maximum allowable output torques shown below.

\*\*Ratings based on 40° C ambient conditions.

RDM/RDG090 Inertia				
	Stator	1 Stack	2 Stack	3 Stack
RDM Motor Armature Inertia (+/-5%)	lb-in-sec <sup>2</sup> (kg-cm <sup>2</sup> )	0.00054 (0.609)	0.00097 (1.09)	0.00140 (1.58)
RDG Gearmotor Armature Inertia* (+/-5%)	lb-in-sec <sup>2</sup> (kg-cm <sup>2</sup> )	0.00114 (1.29)	0.00157 (1.77)	0.00200 (2.26)

\*Add armature inertia to gearing inertia for total inertia.

Radial Load and Bearing Life						
RPM	50	100	250	500	1000	3000
RDM090 lbf (N)	427 (1899)	340 (1512)	250 (1112)	198 (881)	158 (703)	109 (485)
RDG090 lbf (N)	350 (1557)	278 (1237)	205 (912)	163 (725)	129 (574)	89 (396)

Side load ratings shown above are for 10,000 hour bearing life at 25mm from motor face at given rpm.

RDG090 Gearmotor Mechanical Ratings					
Model	Ratio	Maximum Allowable Output Torque-Set by User lbf-in (Nm)	Output Torque at Motor Speed for 10,000 Hour Life		
			1000 RPM lbf-in (Nm)	2500 RPM lbf-in (Nm)	3300 RPM lbf-in (Nm)
RDG090-004	4:1	2078 (234.8)	698 (78.9)	530 (59.9)	488 (55.1)
RDG090-005	5:1	1798 (203.1)	896 (101.2)	680 (76.8)	626 (70.7)
RDG090-010	10:1	1126 (127.2)	1043 (117.8)	792 (89.5)	729 (82.4)
RDG090-016	16:1	2078 (234.8)	1057 (119.4)	803 (90.7)	739 (83.5)
RDG090-020	20:1	2078 (234.8)	1131 (127.8)	859 (97.1)	790 (89.3)
RDG090-025	25:1	1798 (203.1)	1452 (164.1)	1103 (124.6)	1015 (114.7)
RDG090-040	40:1	2078 (234.8)	1392 (157.3)	1057 (119.4)	973 (109.9)
RDG090-050	50:1	1798 (203.1)	1787 (201.9)	1358 (153.4)	1249 (141.1)
RDG090-100	100:1	1126 (127.2)	1100 (124.3)	1100 (124.3)	1100 (124.3)

Two torque ratings for the RDG gearmotors are given in the table above. The left hand columns give the maximum (peak) allowable output torque for the indicated ratios of each size RDG gearmotor. This **is not** the rated output torque of the motor multiplied by the ratio of the reducer.

It is possible to select a configuration of the motor selection and gear ratio such that the rated motor torque, multiplied by the gear ratio exceeds these ratings. It is the responsibility of the user to ensure that the settings of the system do not allow these values to be exceeded.

The right hand columns give the output torque at the indicated speed which will result in 10,000 hour life (L10). The setup of the system will determine the actual output torque and speed.

RDG090 Gearing Reflected Inertia					
Single Reduction			Double Reduction		
Gear Stages	lbf-in-sec <sup>2</sup>	(kg-cm <sup>2</sup> )	Gear Stages	lbf-in-sec <sup>2</sup>	(kg-cm <sup>2</sup> )
4:1	0.0000154	(0.174)	16:1	0.000115	(0.130)
5:1	0.0000100	(0.113)	20:1, 25:1	0.0000756	(0.0854)
10:1	0.0000265	(0.0300)	40:1, 50:1, 100:1	0.0000203	(0.0230)

Backlash and Efficiency		
	Single Reduction	Double Reduction
Backlash at 1% Rated Torque	10 Arc min	13 Arc min
Efficiency	91%	86%

RDM090 Motor and RDG090 Gearmotor Weights					
		RDM090 without Gears	RDG090 with 1 Stage Gearing	RDG090 with 2 Stage Gearing	Added Weight for Brake
1 Stack Stator	lb (kg)	12.5 (5.7)	20.5 (9.3)	23.5 (10.7)	4.7 (1.2)
2 Stack Stator	lb (kg)	15.5 (7.0)	23.5 (10.7)	26.5 (12)	
3 Stack Stator	lb (kg)	18.5 (8.4)	26.5 (12.0)	29.5 (13.4)	

# TDM/X060 Linear Actuator Dimensions

## TDM/X060 Double Side Mount or Extended Tie Rod Mount

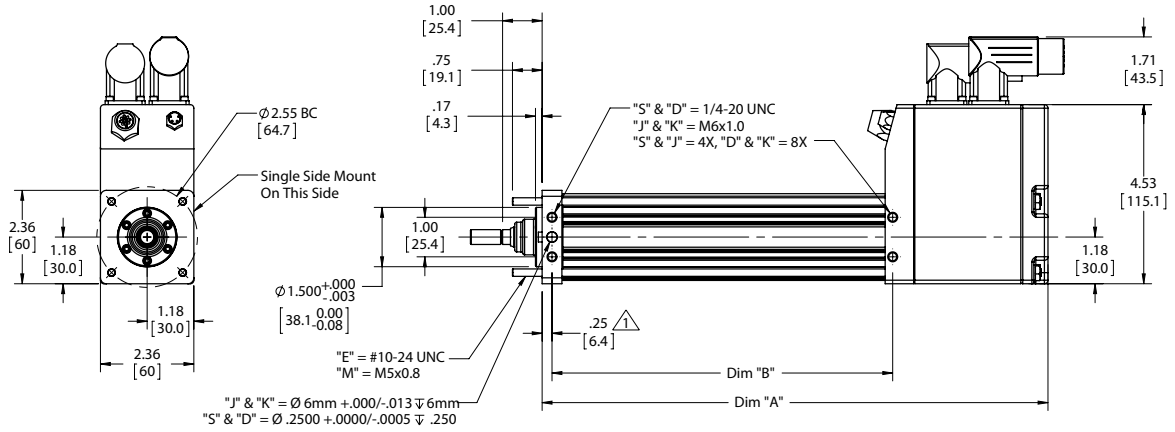

## TDM/X060 Side Trunnion Mount or Rear Clevis Mount

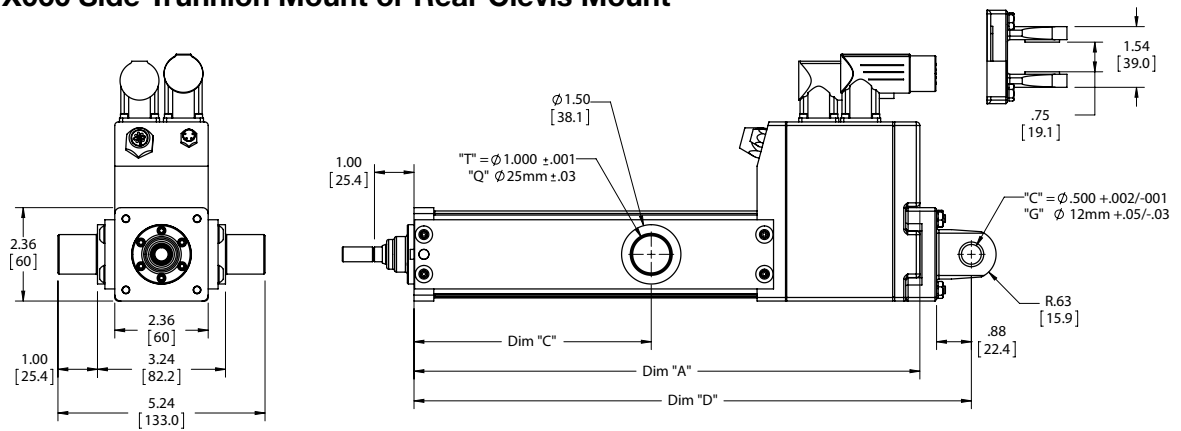

## TDM/X060 Front, Rear, or Front and Rear Flange Mount

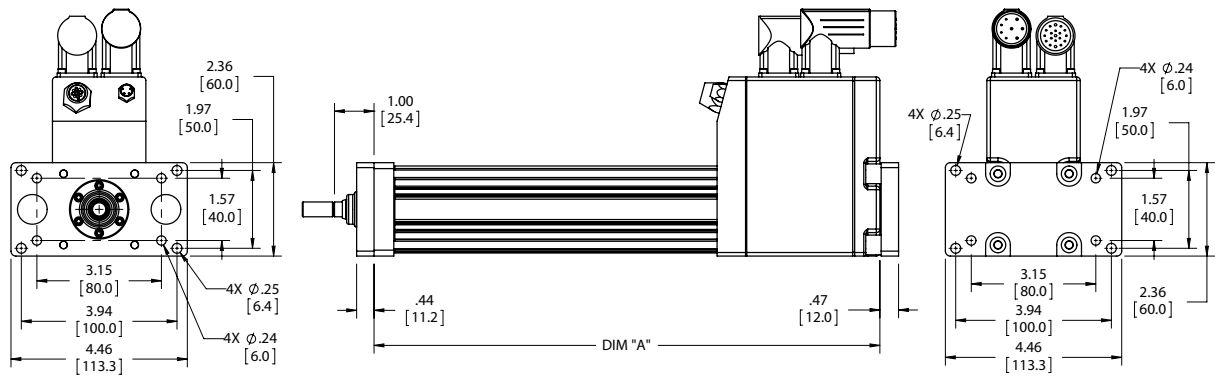

DIM	3 inch (75 mm) stroke in (mm)	6 inch (150 mm) stroke in (mm)	10 inch (250 mm) stroke in (mm)	12 inch (300 mm) stroke in (mm)
A	9.79 (248.7)	12.79 (324.9)	16.79 (426.5)	18.79 (477.3)
B	5.62 (142.8)	8.62 (218.9)	12.62 (320.6)	14.62 (371.4)
C	3.00 (76.2)	6.00 (152.4)	10.00 (254.0)	12.00 (304.8)
D	11.10 (281.9)	14.10 (358.1)	18.10 (459.7)	20.10 (510.5)

Note: Add 1.75 inches to dimensions "A", "B" and "D" if ordering a brake. Add .50 inches to dimensions "A", "C" and "D" and dimension if ordering a splined  $\triangle$  main rod.

# TDM/X075 Linear Actuator Dimensions

## TDM/X075 Double Side Mount or Extended Tie Rod Mount

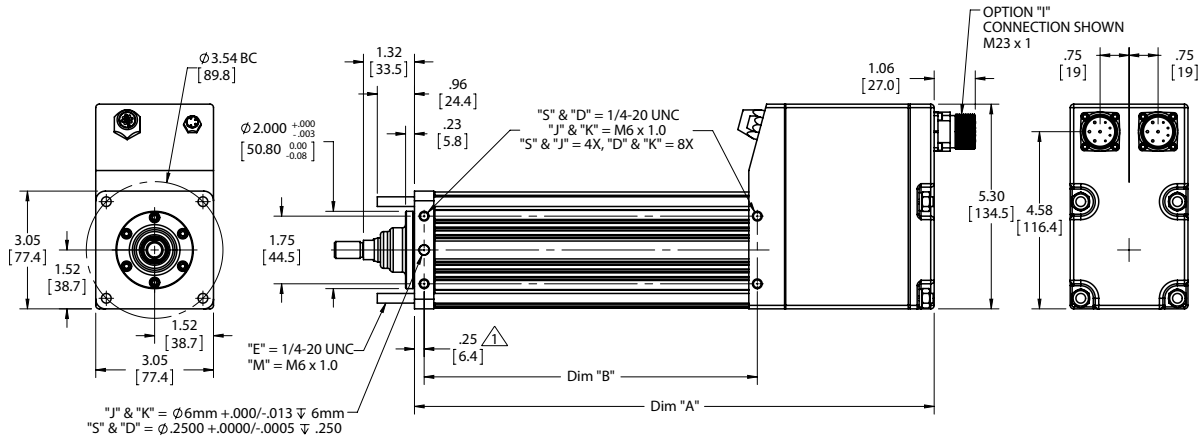

## TDM/X075 Side Trunnion Mount or Rear Clevis Mount

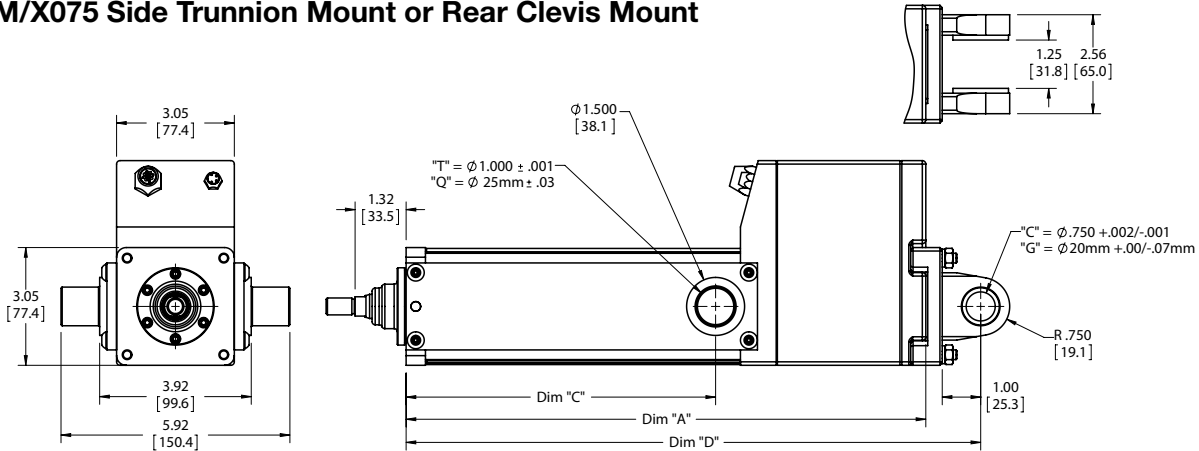

## TDM/X075 Front, Rear, or Front and Rear Flange Mount

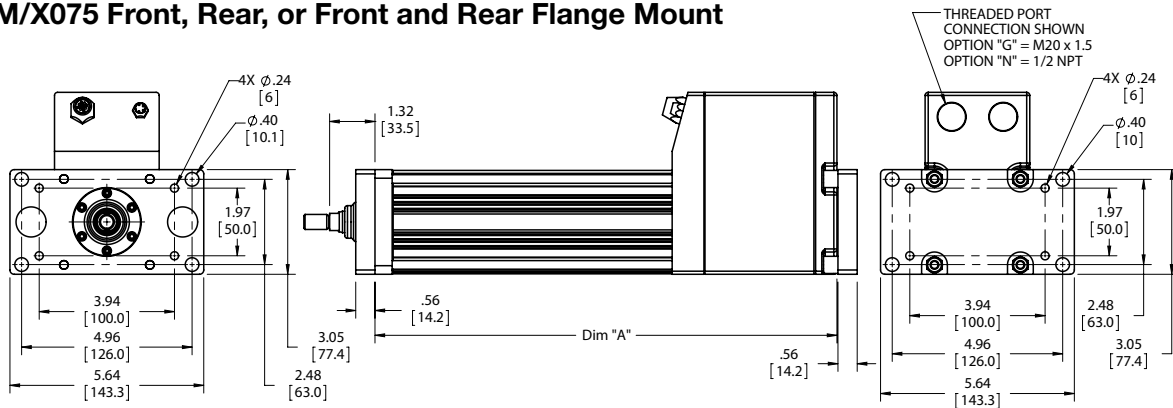

DIM	3 inch (75 mm) stroke in (mm)	6 inch (150 mm) stroke in (mm)	10 inch (250 mm) stroke in (mm)	12 inch (300 mm) stroke in (mm)	14 inch (350 mm) stroke in (mm)	18 inch (450 mm) stroke in (mm)
A	10.98 (278.9)	13.45 (341.6)	17.95 (455.9)	19.95 (506.7)	21.95 (557.5)	25.95 (659.1)
B	6.15 (156.2)	8.62 (218.9)	13.12 (333.2)	15.12 (384.0)	17.12 (434.8)	21.12 (536.4)
C	5.38 (136.7)	8.00 (203.2)	10.00 (254.0)	12.00 (304.8)	14.00 (355.6)	18.00 (457.2)
D	12.40 (315.0)	14.87 (377.7)	19.37 (492.0)	21.37 (542.8)	23.37 (593.6)	27.37 (695.2)

Note: Add 1.61 inches to dimensions "A", "B" and "D" if ordering a brake. Add 1.2 inches to dimensions "A", "C" and "D" and dimension if ordering a splined  $\nabla$  main rod.

# Options Dimensions

## Anti-Rotate Option

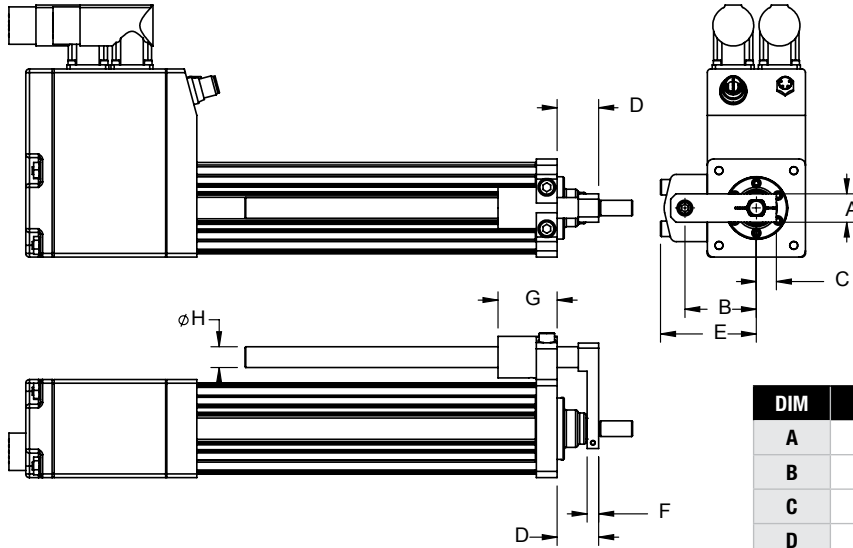

DIM	TDM/X060	TDM/X075
A	0.68 (17.3)	0.82 (20.9)
B	1.72 (43.7)	2.21 (56.1)
C	0.48 (12.2)	0.60 (15.2)
D	1.00 (25.4)	1.32 (33.5)
E	2.31 (58.7)	2.71 (68.8)
F	0.28 (7.1)	0.39 (9.9)
G	1.43 (36.3)	1.70 (43.2)
ØH	0.50 (12.7)	0.63 (15.9)

## Actuator Rod End Option

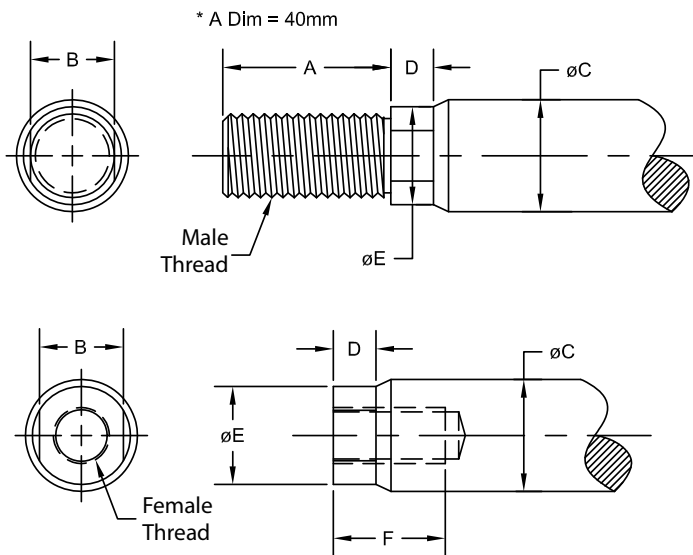

DIM	TDM/X060	TDM/X075
A	0.813 (20.7)	0.750 (19.1)
B	0.375 (9.5)	0.500 (12.7)
ØC	0.500 (12.7)	0.625 (15.9)
D	0.200 (5.1)	0.281 (7.1)
ØE	0.440 (11.2)	0.562 (14.3)
F	0.750 (19.1)	0.750 (19.1)
Male-Inch	3/8-24 UNF-2A	7/16-20 UNF-2A
Male-Metric	M8 x 1-6g	M12 x 1.75-6g*
Female-Inch	5/16-24 UNF-2B	7/16-20 UNF-2B
Female-Metric	M8 x 1-6h	M10 x 1.5-6h

\*When ordering the male M12x1.75 main rod for the TDM/X075 dimension "A" will be 40 mm.

# Rod End Attachment Dimensions

## Clevis Pin

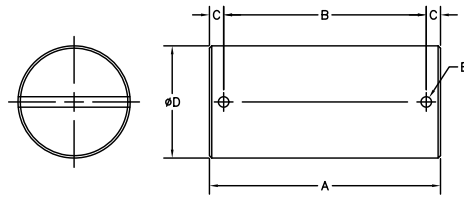

DIM	TDM/X060	TDM/X075
	CP050 in (mm) Rear Clevis, RE050 & RC050	CP075 in (mm) Rear Clevis
A	2.28 (57.9)	3.09 (78.5)
B	1.94 (49.28)	2.72 (69.1)
C	0.17 (4.32)	1.19 (4.82)
$\varnothing D$	0.50 (12.7) -0.001/-0.002	0.75 (19.1) -0.001/-0.002
$\varnothing E$	0.095 (2.41)	0.14 (3.56)

## Spherical Rod Eye

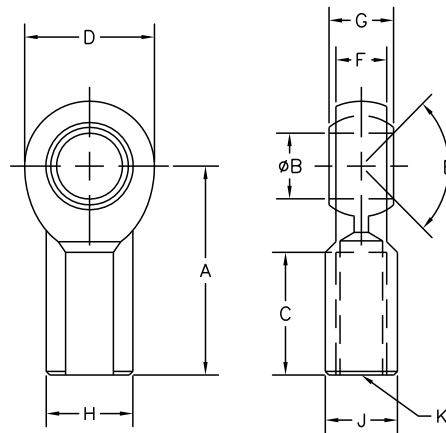

DIM	TDM/X060	TDM/X075
	SRM038 in (mm)	SRM044 in (mm)
A	1.625 (41.3)	1.81 (46.0)
$\varnothing B$	.375 (9.525)	0.438 (11.13)
C	.906 (23.0)	1.06 (26.9)
D	1.0 (25.6)	1.13 (28.7)
E	12 Deg	14 Deg
F	.406 (10.3)	0.44 (11.1)
G	.500 (12.7)	0.56 (14.2)
H	.688 (17.7)	0.75 (19.1)
J	.562 (14.3)	0.63 (16.0)
K	3/8-24	7/16-20

## Rod Eye

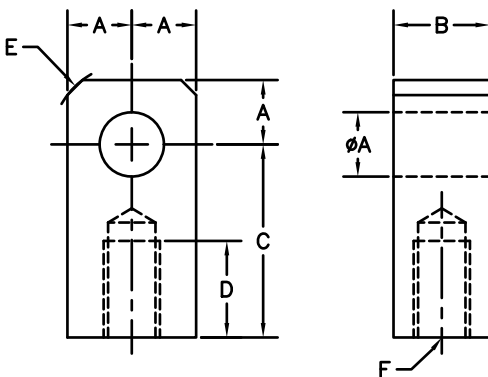

DIM	TDM/X060	TDM/X075
	RE038 in (mm)	RE050 in (mm)
$\varnothing A$	0.50 (12.7)	0.50 (12.7)
B	0.560 (14.2)	0.75 (19.1)
C	1.000 (25.4)	1.50 (38.1)
D	0.500 (12.7)	0.75 (19.1)
E	0.25 x 45° (6.35)	0.63 (15.9)
F	3/8-24	7/16-20

## Rod Clevis

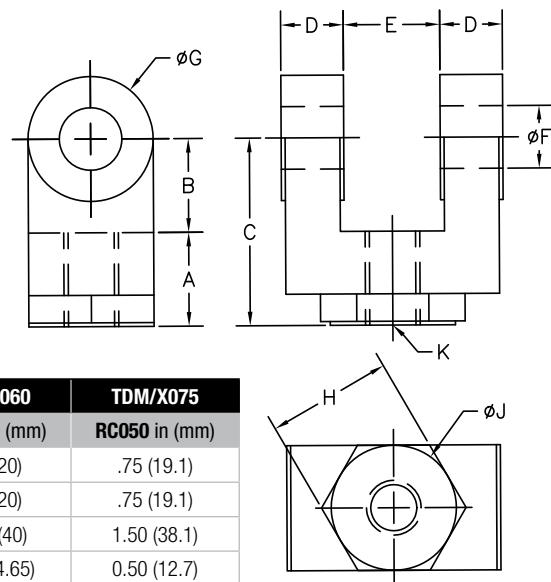

DIM	TDM/X060	TDM/X075
	RC038 in (mm)	RC050 in (mm)
A	.787 (20)	.75 (19.1)
B	.787 (20)	.75 (19.1)
C	1.574 (40)	1.50 (38.1)
D	0.183 (4.65)	0.50 (12.7)
E	0.375 (9.5)	0.765 (19.43)
$\varnothing F$	0.375 (9.5)	0.50 (12.7)
$\varnothing G$	0.75 (19.1)	1.00 (25.4)
H	N/A	1.00 (25.4)
$\varnothing J$	N/A	1.00 (25.4)
K	3/8-24	7/16-20

# RDM/RDG060 Rotary Motor/Gearmotor Dimensions

## RDM060 Dimensions

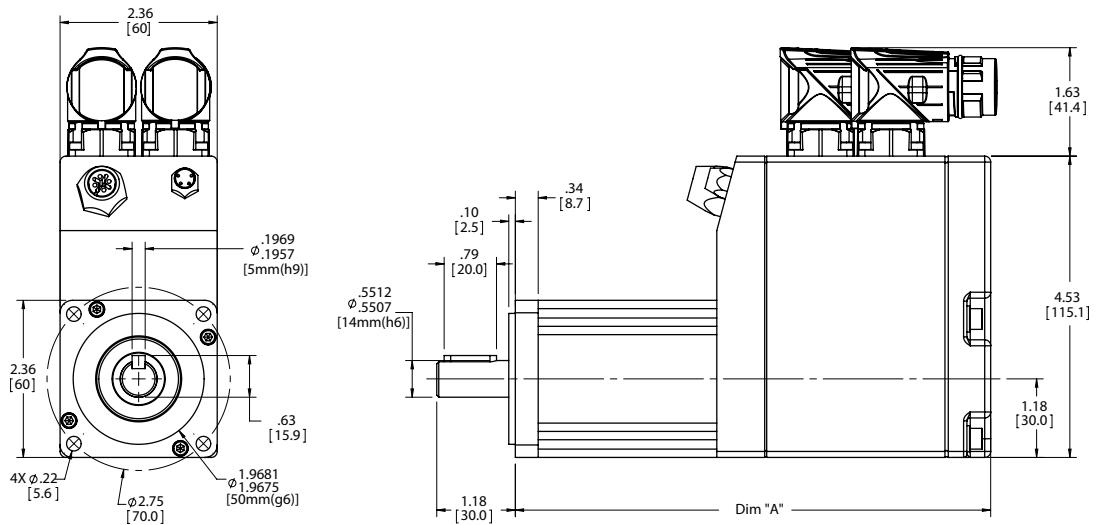

Without Brake Option			
DIM	1 Stack Stator	2 Stack Stator	3 Stack Stator
A	7.146 (185.1)	8.396 (213.3)	9.646 (245.0)

With Brake Option			
DIM	1 Stack Stator	2 Stack Stator	3 Stack Stator
A	7.856 (199.5)	9.106 (231.3)	10.356 (263.0)

## RDG060 Dimensions

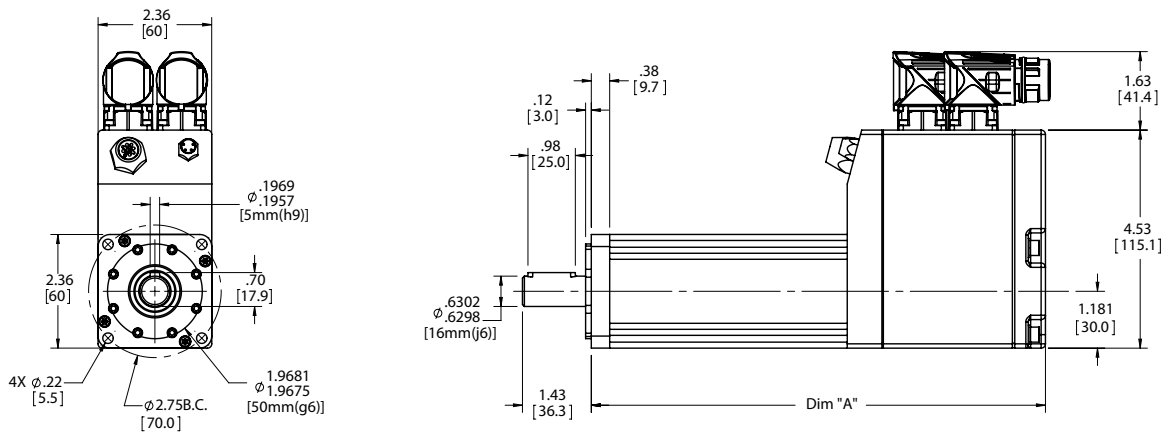

Without Brake Option			
DIM	1 Stack Stator 1 Stage Gearhead	2 Stack Stator 1 Stage Gearhead	3 Stack Stator 1 Stage Gearhead
A	9.434 (240)	10.684 (271)	11.934 (303)
DIM	1 Stack Stator 2 Stage Gearhead	2 Stack Stator 2 Stage Gearhead	3 Stack Stator 2 Stage Gearhead
A	10.479 (266)	11.729 (298)	12.979 (330)

With Brake Option			
DIM	1 Stack Stator 1 Stage Gearhead	2 Stack Stator 1 Stage Gearhead	3 Stack Stator 1 Stage Gearhead
A	10.144 (258)	11.394 (289)	12.644 (321)
DIM	1 Stack Stator 2 Stage Gearhead	2 Stack Stator 2 Stage Gearhead	3 Stack Stator 2 Stage Gearhead
A	11.189 (284)	12.439 (316)	13.689 (348)



# RDM/RDG075 Rotary Motor/Gearmotor Dimensions

## RDM075 Dimensions

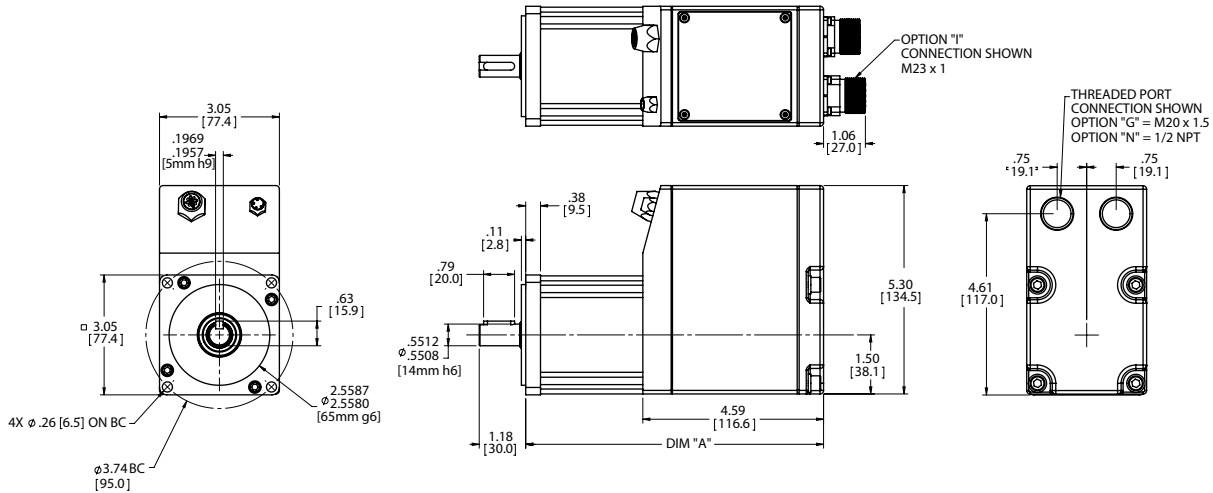

Without Brake Option			
DIM	1 Stack Stator	2 Stack Stator	3 Stack Stator
A	7.57 (192.3)	8.57 (217.7)	9.57 (243.1)

With Brake Option			
DIM	1 Stack Stator	2 Stack Stator	3 Stack Stator
A	8.85 (224.8)	9.85 (250.2)	10.85 (275.6)

## RDG075 Dimensions

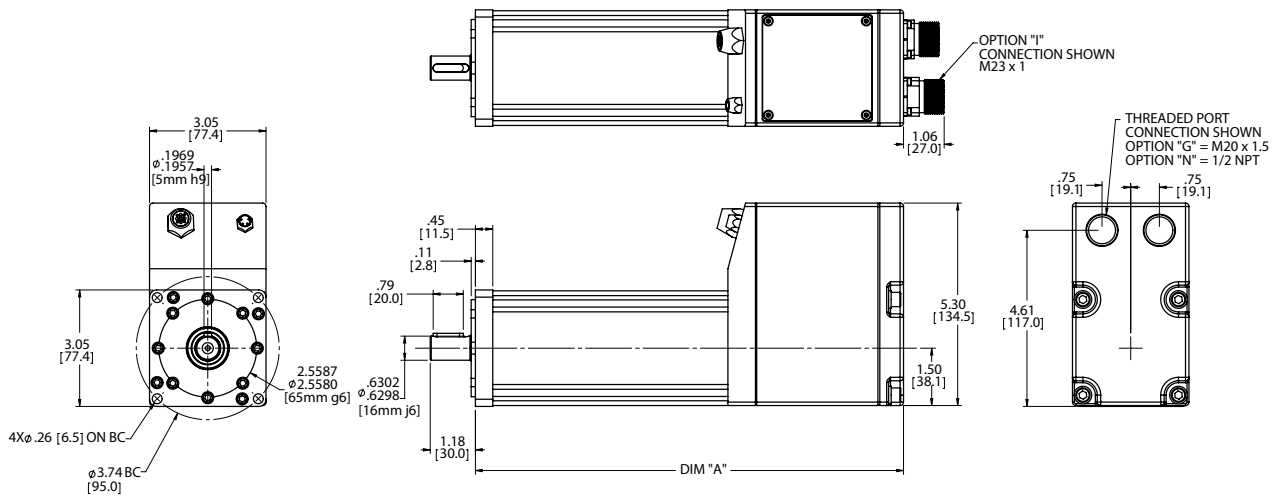

Without Brake Option			
DIM	1 Stack Stator 1 Stage Gearhead	2 Stack Stator 1 Stage Gearhead	3 Stack Stator 1 Stage Gearhead
A	9.19 (233.4)	10.19 (258.8)	11.19 (284.2)

With Brake Option			
DIM	1 Stack Stator 1 Stage Gearhead	2 Stack Stator 1 Stage Gearhead	3 Stack Stator 1 Stage Gearhead
A	10.42 (264.7)	11.42 (290.1)	12.42 (315.5)

# RDM/RDG090 Rotary Motor/Gearmotor Dimensions

## RDM090 Dimensions

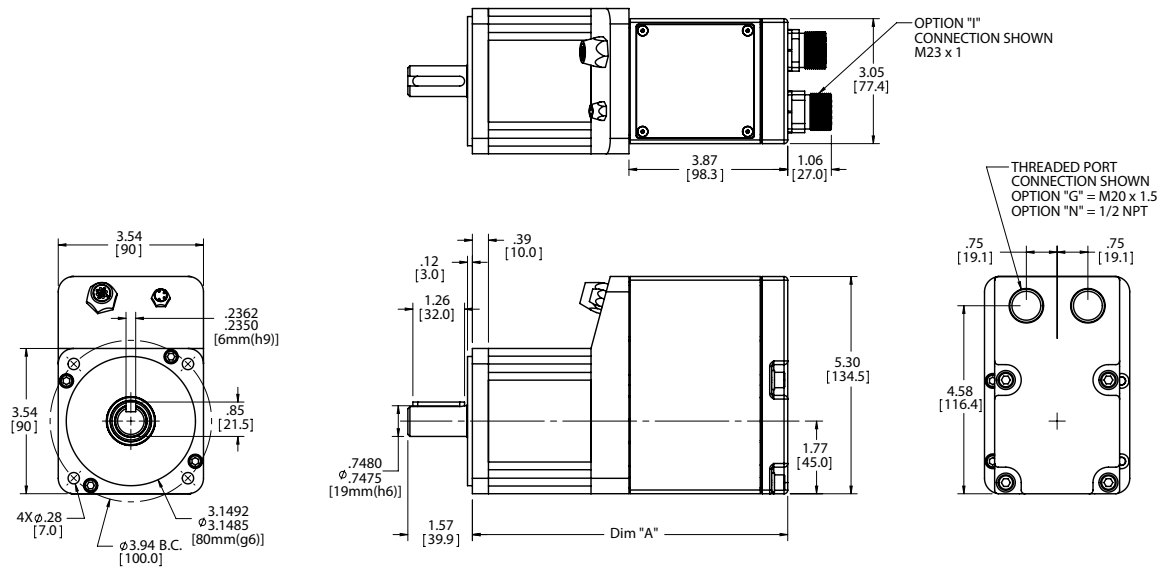

Without Brake Option			
DIM	1 Stack Stator	2 Stack Stator	3 Stack Stator
A	7.69 (195.3)	8.69 (220.7)	9.69 (246.1)

With Brake Option			
DIM	1 Stack Stator	2 Stack Stator	3 Stack Stator
A	9.0 (228.6)	10.00 (254.0)	11.00 (279.4)

## RDG090 Dimensions

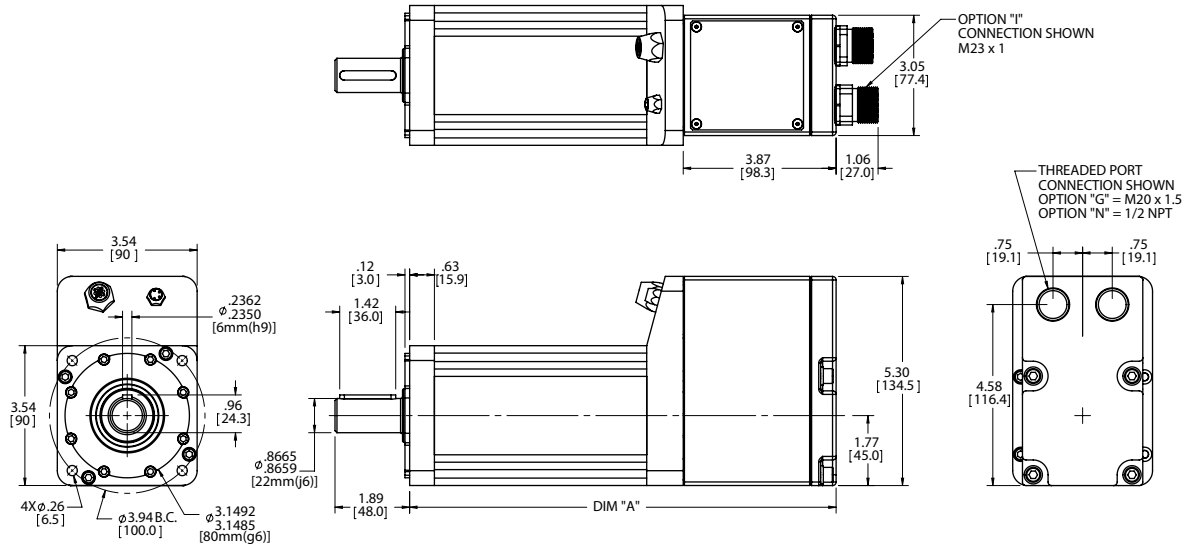

Without Brake Option			
DIM	1 Stack Stator 1 Stage Gearhead	2 Stack Stator 1 Stage Gearhead	3 Stack Stator 1 Stage Gearhead
A	10.80 (274.3)	11.80 (299.7)	12.80 (325.1)
DIM	1 Stack Stator 2 Stage Gearhead	2 Stack Stator 2 Stage Gearhead	3 Stack Stator 2 Stage Gearhead
A	12.06 (306.3)	13.06 (331.7)	14.06 (357.1)

With Brake Option			
DIM	1 Stack Stator 1 Stage Gearhead	2 Stack Stator 1 Stage Gearhead	3 Stack Stator 1 Stage Gearhead
A	12.13 (308.1)	13.11 (333.0)	14.11 (358.4)
DIM	1 Stack Stator 2 Stage Gearhead	2 Stack Stator 2 Stage Gearhead	3 Stack Stator 2 Stage Gearhead
A	13.37 (339.6)	14.37 (365.0)	15.37 (390.4)

# Linear Actuator Ordering Guide

## Tritex II DC TDM/X Linear Actuator Ordering Information

### AAA = Actuator Type

TDM = Tritex II Linear Actuator, standard mechanical capacity  
TDX = Tritex II Linear Actuator, high mechanical capacity

### BBB = Actuator Frame Size

060 = 60 mm  
075 = 75 mm

### CC = Stroke Length

03 = 3 inch (76 mm)  
06 = 6 inch (150 mm)  
10 = 10 inch (254 mm)  
12 = 12 inch (305 mm)  
14 = 14 inch (356 mm) (75 mm only)  
18 = 18 inch (457 mm) (75 mm only)

### DD = Lead (linear travel per screw revolution)

01 = 0.1 inch (2.54 mm)  
02 = 0.2 inch (5.08 mm)  
04 = 0.4 inch (10.16 mm) (60 mm only)  
05 = 0.5 inch (12.7 mm) (75 mm only)

### E = Connections

G = Std Straight Threaded Port w/internal terminals, M20x1.5 (75 mm only)  
N = NPT Threaded Port via Adapter with Internal Terminals, 1/2" NPT (75 mm only)  
I = Intercontec Style - Exlar std, M23 Style Connector  
B = Embedded Leads, 3 ft. std.  
J = Embedded Leads, w/"I" plug, 3 ft. std.  
X = Custom Connectivity

### F = Mounting

B = Front & Rear Flange  
C = Rear Clevis  
G = Metric Rear Clevis  
D = Double Side Mount

K = Metric Double Side Mount  
E = Extended Tie Rod  
M = Metric Extended Tie Rod  
F = Front Flange  
R = Rear Flange  
S = Side Mount  
J = Metric Side Mount  
T = Side Trunnion  
Q = Metric Side Trunnion  
X = Special

### G = Rod End

M = Male US Standard Thread<sup>1</sup>  
A = Male Metric Thread<sup>1</sup>  
F = Female US Standard Thread<sup>1</sup>  
B = Female Metric Thread<sup>1</sup>  
W = Male, US Standard Thread SS<sup>10</sup>  
R = Male Metric Thread SS  
V = Female US Standard Thread SS<sup>10</sup>  
L = Female Metric Thread SS<sup>10</sup>  
X = Special (please specify)

### HH = Feedback Type

HD = Analog Hall Device  
IE = Incremental Encoder, 8192 count resolution  
AF = Absolute Feedback

### III-II = Motor Stator, All 8 Pole

**TDM/X060 Stator Specifications**  
1B8-50 = 1 Stack, 48 VDC, 5000 rpm  
2B8-50 = 2 Stack, 48 VDC, 5000 rpm  
3B8-40 = 3 Stack, 48 VDC, 4000 rpm<sup>4</sup>

### TDM/X075 Stator Specifications

1B8-30 = 1 Stack, 48 VDC, 3000 rpm  
2B8-30 = 2 Stack, 48 VDC, 3000 rpm  
3B8-20 = 3 Stack, 48 VDC, 2000 rpm<sup>4</sup>

### JJJ = Voltage

048 = 12-48 VDC

## AAABBB-CCDD-EFG-HH-III-II-JJJ-KKK- (XX..XX - #####)

### KKK = Option Board

SIO = Standard I/O Interconnect  
IA4 = 4-20 mA Analog I/O  
COP = CANOpen  
CON = CANOpen, non-connectorized<sup>9</sup>  
EIP = SIO plus Ethernet/IP with M12 connector  
EIN = SIO plus Ethernet/IP without M12 connector<sup>9</sup>  
PIO = SIO plus Profinet IO with M12 connector  
PIN = SIO plus Profinet IO without M12 connector<sup>9</sup>  
TCP = SIO plus Modbus TCP with M12 connector  
TCN = SIO plus Modbus TCP without M12 connector<sup>9</sup>

### X..XX = Travel and Housing Options (Multiples Possible)

#### Travel Options

AR = External Anti-rotate  
PF = Preloaded Follower<sup>2</sup>  
L1/2/3 = External Limit Switches<sup>6</sup>  
RB = Rear Brake  
SD = Manual Drive, Side Hex (75 mm)  
HW = Manual Drive, Handwheel with Interlock Switch (TDX075 only)  
PB = Protective Bellows<sup>8</sup>  
SR = Splined Main Rod<sup>7,10</sup>  
XT = Special Travel Options, high temp. bellows<sup>8</sup>

#### Housing Options

P5 = IP65 Sealed Housing (TDM only)  
HC = Type III Hard Coat Anodized<sup>3</sup>  
FG = White Epoxy Coating<sup>3</sup>  
XH = Special Housing Option

### Special Motor Options

XL = Special Lubrication<sup>5</sup>  
XM = Special Motor Option

### ##### = Part Number Designator for Specials

Optional 5 digit assigned PN to designate unique model numbers

#### NOTES:

1. Chrome-plated carbon steel. Threads not chrome-plated.
2. The dynamic load rating of zero backlash, preloaded screws is 63% of the dynamic load rating of the std non-preloaded screws. The calculated travel life of a preloaded screw will be 25% of the calculated travel life of the same size and lead of a non-pre loaded screw.
3. This housing option may indicate the need for special material main rods or mounting.
4. Not available on 0.1" lead.
5. To achieve -40° C operating temperature, specify -XL in the actuator model mask and define Mobilgrease 28 in order notes. Other special lubricants are also available.
6. Limit switch option requires AR option.
7. This option is not sealed and is not suitable for any environment in which contaminants come in contact with actuator and may enter the actuator.
8. Not available with extended tie rod mounting option.
9. Requires customer supplied Ethernet cable through I/O port for Class 1 Div 2 compliance only.
10. Consult Exlar if ordering splined stainless steel main rod.

# Rotary Motor and Gearmotor Ordering Guide

### RDM/G = Motor Type

RDM = Tritex II DC Rotary Motor  
RDG = Tritex II DC Rotary Gearmotor

### AAA = Frame Size

060 = 60 mm  
075 = 75 mm  
090 = 90 mm

### BBB = Gear Ratio

Blank = RDM

#### Single Reduction Ratios

004 = 4:1 005 = 5:1 010 = 10:1

#### Double Reduction Ratios (NA on 75 mm)

016 = 16:1 020 = 20:1  
025 = 25:1 040 = 40:1  
050 = 50:1 100 = 100:1

### C = Shaft Type

K = Keyed  
R = Smooth/Round  
X = Special Shaft

### D = Connections

G = Std straight threaded port w/internal terminals, M20x1.5 (75 & 90 mm only)  
N = NPT threaded port internal terminals, 1/2" NPT (75 & 90 mm only)

I = Intercontec style - Exlar std, M23 Style Connector  
B = Embedded Leads, 3 ft. std.  
J = Embedded Leads, w/"I" plug, 3 ft. std.  
X = Custom Connectivity

### E = Housing Options

G = Exlar Standard  
H = Type III Hard Coat Anodized  
F = White Epoxy Coating  
X = Special or Custom

### F = Brake Option

S = No Brake, Standard  
B = Electric Brake, 24 VDC

### GG = Feedback Type

HD = Analog Hall Device  
IE = Incremental Encoder, 8192 Count Resolution  
AF = Absolute Feedback

### HHH-HH = Motor Stators - All 8 Pole

#### RDM/G060 Stator Specifications

1B8-50 = 1 Stack, 48 VDC, 5000 rpm  
2B8-50 = 2 Stack, 48 VDC, 5000 rpm  
3B8-40 = 3 Stack, 48 VDC, 4000 rpm

## RDM/G AAABBB-CDEF-GG-HHH-HH-III-JJJ (XX...XX) - #####

### Tritex II DC RDM Motor or RDG Gearmotor Ordering Information

#### RDM/G075 Stator Specifications

1B8-40 = 1 Stack, 48 VDC, 4000 rpm  
2B8-30 = 2 Stack, 48 VDC, 3000 rpm  
3B8-20 = 3 Stack, 48 VDC, 2000 rpm

#### RDM/G090 Stator Specifications

1B8-33 = 1 Stack, 48 VDC, 3300 rpm  
2B8-18 = 2 Stack, 48 VDC, 1800 rpm  
3B8-14 = 3 Stack, 48 VDC, 1400 rpm

### III = Voltage

048 = 12-48 VDC

### JJJ = Option Board

SIO = Standard I/O Interconnect  
IA4 = + 4-20 mA Analog I/O  
COP = CANOpen  
CON = CANOpen, non-connectorized<sup>2</sup>  
EIP = SIO plus EtherNet/IP with M12 connector  
EIN = SIO plus EtherNet/IP without M12 connector<sup>2</sup>  
PIO = SIO plus Profinet IO w/M12 connector  
PIN = SIO plus Profinet IO without M12 connector<sup>2</sup>  
TCP = SIO plus Modbus TCP w/M12 connector  
TCN = SIO plus Modbus TCP without M12 connector<sup>2</sup>

### XX = Special Travel and Housing Options (multiples possible)

HW = Manual Drive, Handwheel with Interlock Switch (75 & 90 mm only)  
SD = Manual Drive, Side (75 & 90 mm only)  
XH = Special Housing Options  
XM = Special Motor Options  
XL = Special Lubrication<sup>1</sup>

### ##### = Part Number Designator for Specials

Optional 5 digit assigned PN to designate unique model no.

#### NOTES:

1. To achieve -40° C operating temperature, specify -XL in the actuator model mask and define Mobilgrease 28 in order notes. Other special lubricants are also available.
2. Requires customer supplied Ethernet cable through I/O port for Class 1 Div 2 compliance only. Also N/A on 60 mm.

# Cables/Accessories Ordering Guide

Tritex II DC Series Cable & Accessories		Part No.
<b>"G" Connection Accessories</b> (N/A for 60 mm)		
Nickel plated cable gland- M20 x 1.5 - CE shielding- 2 required		GLD-T2M20 x 1.5
Power cable prepared on one end for use with GLD-T2M20 x 1.5 xxx = Length in ft, Standard lengths 015, 025, 050, 075, 100		CBL-TDIPC-RAW-xxx
I/O cable prepared on one end for use with GLD-T2M20 x 1.5 xxx = Length in ft, Standard lengths 015, 025, 050, 075, 100		CBL-T2IOC-RAW-xxx
<b>"N" Connection Accessories</b> (N/A for 60 mm)		
M20 x 1.5 to 1/2" NPT threaded hole adapter for use with conduit		ADAPT-M20-NPT1/2
<b>"I" Connection</b>		
Power cable with M23 8 pin xxx = Length in feet, std lengths 015, 025, 050, 075, 100		CBL-TTIPC-SMI-xxx
I/O cable with M23 19 pin xxx = Length in feet, std lengths 015, 025, 050, 075, 100		CBL-TTIOC-SMI-xxx
<b>Communications Accessories - Tritex uses a 4 pin M8 RS485 communications connector</b>		
Recommended PC to Tritex communications cable-USB/RS485 to M8 connector - xxx = Length in feet, 006 or 015 only		CBL-T2USB485-M8-xxx
<b>Multi-Drop RS485 Accessories</b>		
RS485 splitter - M8 Pin plug to double M8 Socket receptacle		TT485SP
Multidrop Communications Cable M8 to M8 for use with TT485SP/RS485 splitter - xxx = Length in feet, 006 or 015 only		CBL-TTDAS-xxx
<b>Multi-Purpose Communications Accessories for long runs, requires terminal block interconnections</b>		
USB to RS485 convertor/cable - USB to RS485 flying leads - xxx = Length in feet, 006 or 015 only		CBL-T2USB485-xxx
Communications cable M8 to flying leads cable xxx = Length in feet, standard lengths 015, 025, 050, 075, 100		CBL-TTCOM-xxx
<b>Option Board Cables and Accessories</b>		
CAN Male to Female Molded 3 ft. cable		CBL-TTCAN-SMF-003
CAN Male to Female Molded 6 ft. cable		CBL-TTCAN-SMF-006
CAN Cable, no connectors – per foot		CBL-TTCAN-S
CAN Male connector, field wireable		CON-TTCAN-M
CAN Female connector, field wireable		CON-TTCAN-F
CAN Splitter		CON-TTCAN-SP
EIP, PIO and TCP option Ethernet cable - M12 to RJ45 cable xxx = Length in feet, standard lengths 015, 025, 050, 075, 100. For EIN, PIN & TCN see note 9, page 22.		CBL-T2ETH-R45-xxx
<b>Electrical Accessories</b>		
48VDC, 10Amp Unregulated Power Supply		TTPS1048
48VDC, 15Amp Unregulated Power Supply		TTPS1548
Shunt resistor used for Dynamic Braking		TTSR1
Replacement -AF Battery - 75 mm frame only used for absolute feedback option		T2BAT1
Replacement -External Battery, Absolute Feedback option only (60mm frame)		T2BAT2
Replacement -AF Battery, DIN Rail mounted, Absolute Feedback option only (60mm frame)		48224
Surge Filter DIN rail mounted		TDCESF1
Replacement Normally Closed External Limit Switch (Turck Part No. BIM-UNT-RP6X)		43404
Replacement Normally Open External Limit Switch (Turck Part No. BIM-UNT-AP6X)		43403
<b>Mechanical Accessories</b>		
Clevis Pin for TDM/X060 Rod Clevis & Rear Clevis		CP050*
Clevis Pin for TDM/X075 Rear Clevis		CP075
Spherical Rod Eye for TDM/X060 male "M" rod end 3/8-24 thread		SRM038
Spherical Rod Eye for TDM/X075 male "M" rod end 7/16-20 thread		SRM044
Rod Eye for TDM/X075 male "M" rod end 7/16-20 thread		RE050
Rod Clevis for TDM/X060 male "M" rod end 3/8-24 thread		RC038
Rod Clevis for TDM/X075 male "M" rod end 7/16-20 thread		RC050
Jam Nut for TDM/X060 male rod end, 3/8-24		JAM3/8-24-SS
Jam Nut for TDM/X075 male rod end, 7/16-20		JAM7/16-20-SS

\*Also available for TDM/X075 with RC050, RE050

## Options/Accessories



### CBL-T2USB485-M8-xxx

Our recommended communications cable. No special drivers or setup required for use with MS Windows™.



### CBL-T2USB485-xxx

Use for terminal connections with CBL-TTCOM for long cable runs. No special drivers or setup required for use with MS Windows™.



### CBL-TTCOM-xxx

Use with CBL-T2USB485-xxx for long cable runs.



### CBL-TTDAS-xxx

For use with TT485SP for multi-drop applications.

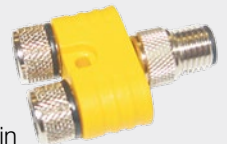

### TT485SP

RS485 communications splitter. Use to daisy-chain multiple Tritex actuators.



### CON-TTCAN-SP

CAN splitter



### CON-TTCAN-M

M12 Field wireable connector

### TDCESF1

Surge filter designed for use on Tritex 48 VDC rotary and linear actuators provides EFT/B and surge disturbance immunity to IEC/EN 61800-3:2004-08 Second Environment (industrial) levels. Electrical Fast Transient/Burst (EET/B) and surge disturbances are caused by a number of events including switching inductive loads, relay contact bounce, power system switching activity or faults, nearby lightning strikes, etc.



Exlar is a business group of Curtiss-Wright Controls. Exlar designs, manufactures and sells linear and rotary motion products worldwide.

**Our global sales channel is ready to assist you in product selection and support. Please contact us for literature on other product families. Visit [www.exlar.com/contacts](http://www.exlar.com/contacts) for a full listing of our sales offices around the world.**

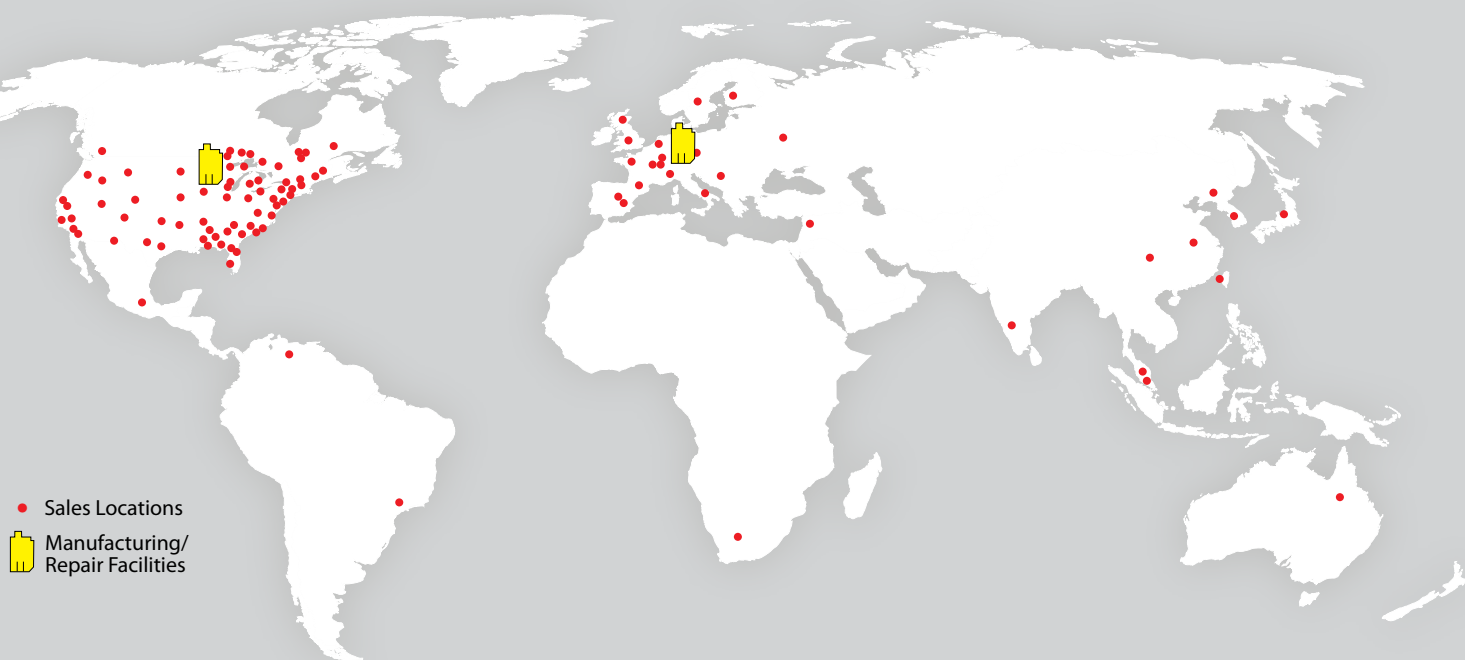

### USA

Exlar Corporation—Headquarters  
18400 West 77th Street  
Chanhassen, MN 55317  
TEL: 952.500.6200  
Toll Free in US and Canada: 855.620.6200  
General FAX: 952.368.4877  
Order Only FAX: 952.368.4359  
[www.exlar.com](http://www.exlar.com)

### Europe

Exlar Europe GmbH  
Frankfurter Str. 107  
65479 Raunheim  
Germany  
TEL: +49 6142 17590-0  
FAX: +49 6142 17590-69  
[www.exlar.com](http://www.exlar.com)



Curtiss-Wright is an innovative engineering company that provides highly engineered, critical function products, systems and services in the areas of flow control, motion control and metal treatment to the defense, energy and commercial/industrial markets.