

GSM Series Linear Actuators with Integrated Motor

GSM Series—Standard Capacity Roller Screw Option

This design incorporates Exlar's patented roller screw technology with an integral brushless servo motor for medium to high performance motion control applications. The GSM Series offers 5 times the travel life of similarly sized ball screw actuators. It also provides a smaller package with higher speed and higher load capacity than ball screws and other traditional rotary to linear conversion mechanisms. These features make the GSM Series an excellent replacement for ball screw actuators.

Selection of the proper feedback configuration allows GSM Series actuators to be powered by nearly every brand of brushless motor amplifier on the market. This flexibility allows GSM Series actuators to be incorporated into the highest performance single and multi-axis motion control systems in use today. In applications varying from food and beverage packaging, to multi-axis turning centers, to aircraft assembly, the GSM Series of actuators show incredible performance and durability.

Exlar's T-LAM technology incorporated into the motor design provides a solution with 35% more torque in the same package size as traditional brushless motors. The efficiencies of the GSM Series are a result of the limited heat generation qualities inherent in the segmented stator design. The elimination of end turns in the stator, and the use of thermally conductive potting removes the parts most susceptible to failure in a traditional stator. Other benefits include:

- Neodymium iron boron magnets provide high flux density and maximum motor torque.
- Thermally conductive potting of the entire stator provides increased heat dissipation and provides protection from contamination in oil-cooled units.
- Each stator segment contains individual phase wiring. External winding of individual segments provides maximum slot fill for maximum motor performance.
- Motors with T-LAM technology have Class H insulation systems compliant with UL requirements.



**Roller Screw
Driven** BY EXLAR

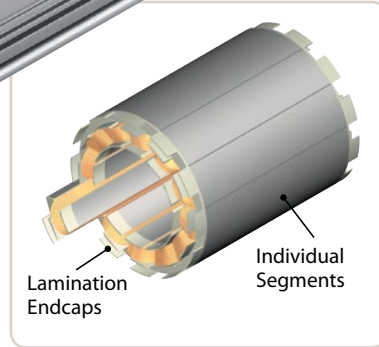

Features/Characteristics

T-LAM™ segmented lamination stator technology

2.25, 3.3 or 3.9 inch frame size

3, 4, 5.9, 6, 10, 12, 14, 18 and 24 inch strokes

0.1, 0.2, 0.4, 0.5 and .75 inch lead roller screws

7 to 75 lbf-in torque motor availability

Up to 33 inch per second linear speeds

92 to 1983 lbf thrust capacity depending on motor selection

Front flange, rear flange, rear clevis, trunnion, side, double side or extended tie rods mounting options

Encoder feedback with MS style connectors

Molded and shielded cables available

Anodized aluminum housing

Competitively priced with ball screw actuators

5 times the life of a similar sized ball screw actuator

IP54S or IP65S sealing

Class 180 H insulation

UL recognized component

Exlar GSM Series Linear Actuators Applications Include:

Hydraulic cylinder replacement	Medical equipment	Lifts	Ventilation control systems
Ball screw replacement	Conveyor diverters / gates	Product sorting	Pressing
Pneumatic cylinder replacement	Plastics equipment	Material cutting	Process control
Chip and wafer handling	Cut-offs	Material handling	Tube bending
Automated flexible fixturing	Die cutters	Riveting / fastening / joining	Welding
Dispensers	Packaging machinery	Molding	Stamping
Machine tool	Entertainment	Volumetric pumps	Test stands
Automated assembly	Sawmill equipment	Semiconductor	Tension control
Parts clamping	Open / close doors	Pick and place systems	Web guidance
Automatic tool changers	Fillers	Robot manipulator arms	Wire winding
Volumetric pumps	Formers	Simulators	Food Processing
	Precision grinders	Precision valve control	
	Indexing stages		

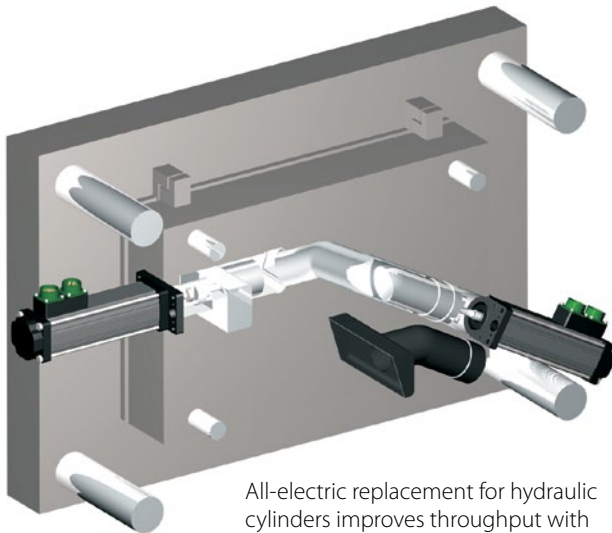

All-electric replacement for hydraulic cylinders improves throughput with servo control and less maintenance for core-pull cylinders.

GSM-Series actuators can provide the precision at high force loads for fluid dispensing in a medical environment.

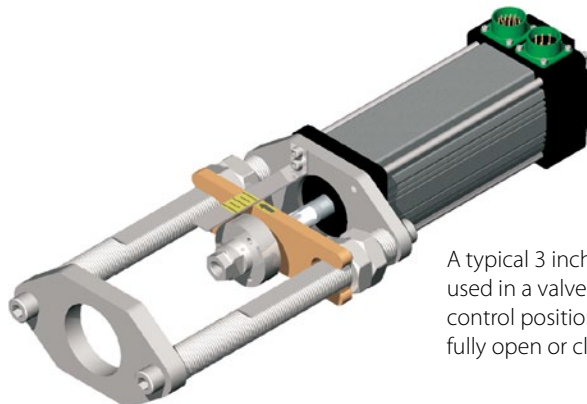

A typical 3 inch stroke GSM Series actuator used in a valve-modulating application can control position to $\pm 0.5\%$ while ready to fully open or close in less than 200 mSec.

GSM Series Linear Actuators with Integrated Motor

GSM Series Performance

The below speed vs. force curves represent approximate continuous thrust ratings at indicated linear speed. Different types of servo amplifiers will offer varying motor

torque and thus actuator thrust. These values are at constant velocity and do not account for motor torque required for acceleration.

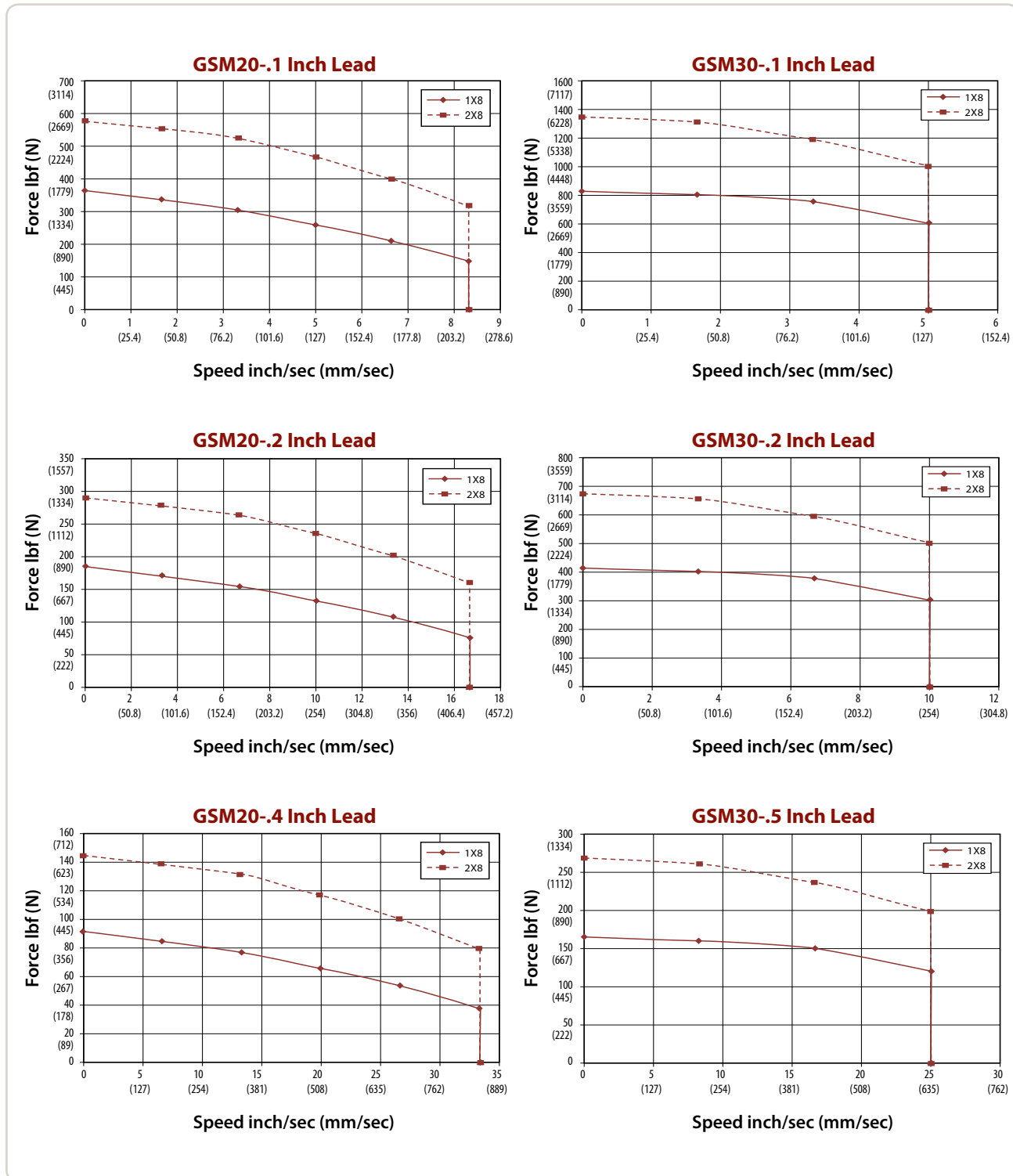

Test data derived using NEMA recommended aluminum heatsink 10" x 10" x 1/4" on GSM20 and 10" x 10" x 3/8" on GSM30

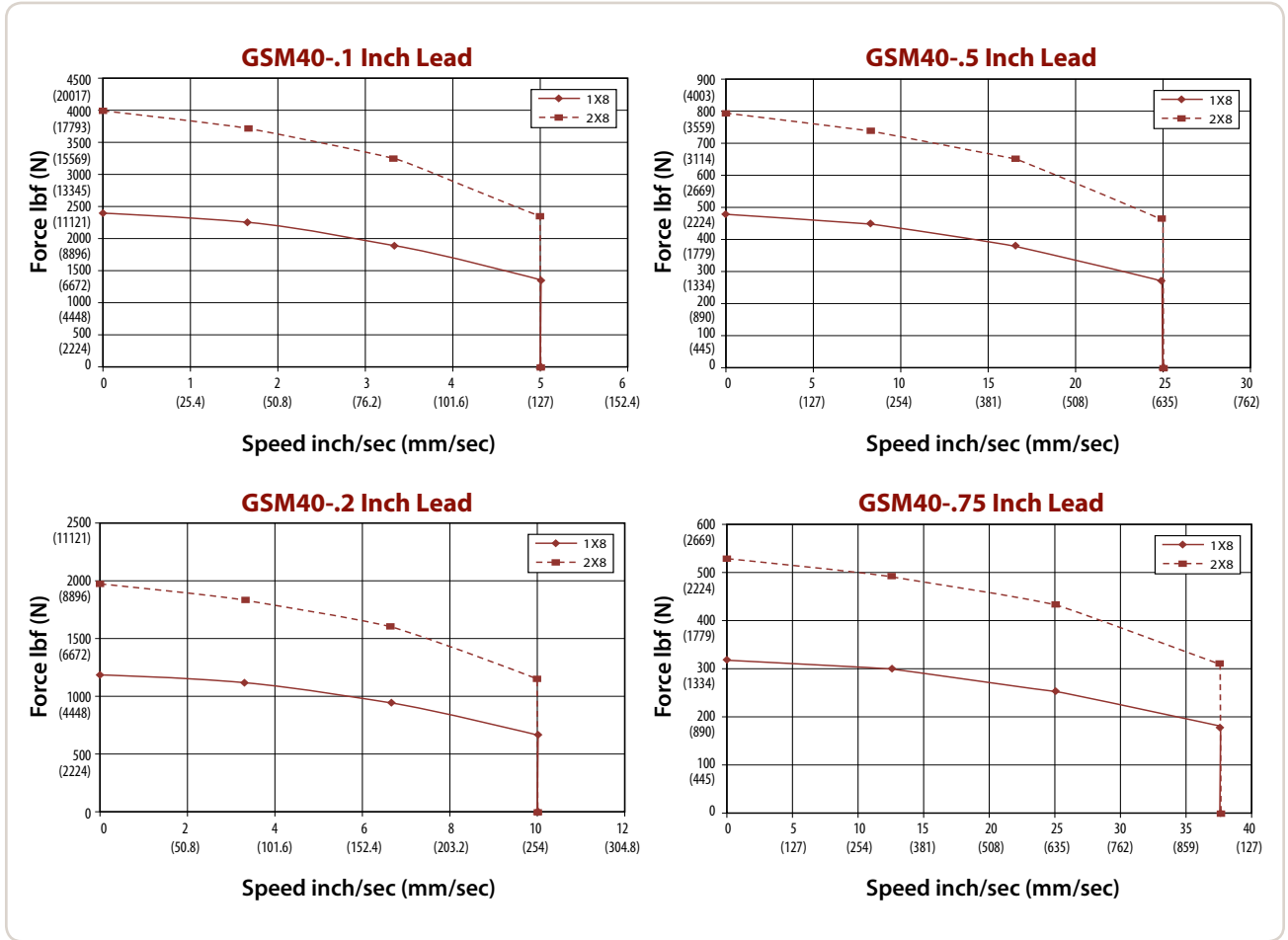

Test data derived using NEMA recommended aluminum heatsink 12" x 12" x 1/2" on GSM40

Life Curves

The estimated travel life indicates the approximate expected travel life from the roller screw mechanism within the GSM30 at indicated cubic mean load. The chart below represents L_{10} travel life estimates. The reliability for these values is 90%. For higher than 90% reliability, the result should be multiplied by the following factors: 95% x 0.62; 96% x 0.53; 97% x 0.44; 98% x 0.33; 99% x 0.21. This information assumes that the roller screw is properly maintained and lubricated. The equation used to calculate the L_{10} life is: $\text{Travel} (\frac{F}{C})^3 \times S$, where S = lead in millions of inches/mm. Where C = the dynamic load rating of the screw and F is the cubic mean load rating of the application. For higher than 90% reliability, derating of this value is implemented. Contact your local sales representative for details.

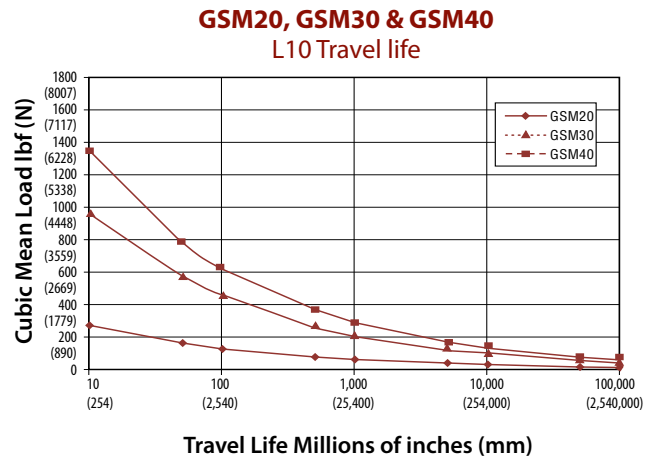

GSM Series Linear Actuators with Integrated Motor

GSM20 & GSM30 Performance Specifications

Model No.	Frame Size in (mm)	Stroke in (mm)	Screw Lead in (mm)	Continuous Force Rating	Max Velocity	Maximum Static Load	Armature Inertia**	Dynamic Load Rating	Weight (approx.)
				lb (N) 1 stack/2 stack	in/sec (mm/sec)	lb (N)	lb-in-s ² (Kg-m ²)	lb (N)	lb (kg)
GSM20-0301	2.25 (57)	3 (76)	0.1 (2.54)	367/578 (1,632/2,571)	8.33 (211.67)	750 (3336)	0.00101 (0.000114)	1568 (6970)	6.5 (2.9)
GSM20-0302			0.2 (5.08)	195/307 (867/1,366)	16.77 (423.33)			1219 (5422)	
GSM20-0304			0.4 (10.16)	103/163 (459/723)	33.33 (846.67)			738 (3283)	
GSM20-0601	2.25 (57)	6 (152)	0.1 (2.54)	367/578 (1,632/2,571)	8.33 (211.67)	750 (3336)	0.00114 (0.000129)	1567 (6970)	7.0 (3.2)
GSM20-0602			0.2 (5.08)	195/307 (867/1,366)	16.67 (423.33)			1219 (5422)	
GSM20-0604			0.4 (10.16)	103/163 (459/723)	33.33 (846.67)			738 (3283)	
GSM20-1001	2.25 (57)	10 (254)	0.1 (2.54)	367/578 (1,632/2,571)	8.33 (211.67)	750 (3336)	0.00133 (0.000150)	1567 (6970)	7.5 (3.4)
GSM20-1002			0.2 (5.08)	195/307 (867/1,366)	16.67 (423.33)			1219 (5422)	
GSM20-1004			0.4 (10.16)	103/163 (459/723)	33.33 (846.67)			738 (3283)	
GSM20-1201	2.25 (57)	12 (305)	0.1 (2.54)	367/578 (1,632/2,571)	8.33 (211.67)	750 (3336)	0.00143 (0.000162)	1567 (6970)	8.0 (3.6)
GSM20-1202			0.2 (5.08)	195/307 (867/1,366)	16.67 (423.33)			1219 (5422)	
GSM20-1204			0.4 (10.16)	103/163 (459/723)	33.33 (846.67)			738 (3283)	
GSM30-0301	3.3 (84)	3 (76)	0.1 (2.54)	792/1,277 (3,521/5,680)	5 (127)	1620 (7206)	0.00319 (0.000360)	3310 (14724)	9.5 (4.3)
GSM30-0302			0.2 (5.08)	449/724 (1,995/3,219)	10 (254)			3570 (15880)	
GSM30-0305			0.5 (12.7)	190/306 (845/1,363)	25 (635)			3016 (13416)	
GSM30-0601	3.3 (84)	5.9 (150)	0.1 (2.54)	792/1,277 (3,521/5,680)	5 (127)	1620 (7206)	0.00361 (0.000408)	3310 (14724)	11.5 (5.2)
GSM30-0602			0.2 (5.08)	449/724 (1,995/3,219)	10 (254)			3570 (15880)	
GSM30-0605			0.5 (12.7)	190/306 (845/1,363)	25 (635)			3016 (13416)	
GSM30-1001	3.3 (84)	10 (254)	0.1 (2.54)	792/1,277 (3,521/5,680)	5 (127)	1620 (7206)	0.00416 (0.00047)	3310 (14724)	19 (8.6)
GSM30-1002			0.2 (5.08)	449/724 (1,995/3,219)	10 (254)			3570 (15880)	
GSM30-1005			0.5 (12.7)	190/306 (845/1,363)	25 (635)			3016 (13416)	
GSM30-1201	3.3 (84)	12 (305)	0.1 (2.54)	792/1,277 (3,521/5,680)	5 (127)	1620 (7206)	0.00443 (0.000501)	3310 (14724)	20.5 (9.3)
GSM30-1202			0.2 (5.08)	449/724 (1,995/3,219)	10 (254)			3570 (15880)	
GSM30-1205			0.5 (12.7)	190/306 (845/1,363)	25 (635)			3016 (13416)	
GSM30-1401	3.3 (84)	14 (356)	0.1 (2.54)	792/1,277 (3,521/5,680)	5 (127)	1620 (7206)	0.00473 (0.000534)	3310 (14724)	22 (10)
GSM30-1402			0.2 (5.08)	449/724 (1,995/3,219)	10 (254)			3570 (15880)	
GSM30-1405			0.5 (12.7)	190/306 (845/1,363)	25 (635)			3016 (13416)	
GSM30-1801	3.3 (84)	18 (457)	0.1 (2.54)	792/1,277 (3,521/5,680)	5 (127)	1620 (7206)	0.00533 (0.000602)	3310 (14724)	25 (11.3)
GSM30-1802			0.2 (5.08)	449/724 (1,995/3,219)	10 (254)			3570 (15880)	
GSM30-1805			0.5 (12.7)	190/306 (845/1,363)	25 (635)			3016 (13416)	
GSM30-2401	3.3 (84)	24 (610)	0.1 (2.54)	792/1,277 (3,521/5,680)	5 (127)	1620 (7206)	0.00615 (0.000695)	3310 (14724)	30 (13.6)
GSM30-2402			0.2 (5.08)	449/724 (1,995/3,219)	10 (254)			3570 (15880)	
GSM30-2405			0.5 (12.7)	190/306 (845/1,363)	25 (635)			3016 (13416)	

**Inertia +/- 5%

See page 47 for definition of terms.

GSM40 Performance Specifications

Model No.	Frame Size in (mm)	Stroke in (mm)	Screw Lead in (mm)	Continuous Force Rating lb (N) 1 stack/2 stack	Max Velocity in/sec (mm/sec)	Maximum Static Load lb (N)	Armature Inertia** lb-in-s ² (Kg-m ²)	Dynamic Load Rating lb (N)	Weight (approx.) lb (kg)
GSM40-0401	3.9 (99)	4 (102)	0.1 (2.54)	2,089/NA (9,293/NA)	5 (127)	3966 (17642)	0.0140 (0.001582)	4736 (21067)	16 (7.3)
GSM40-0402			0.2 (5.08)	1,194/NA (5,310/NA)	10 (254)			4890 (21751)	
GSM40-0405			0.5 (12.7)	537/NA (2,390/NA)	25 (635)			4218 (18763)	
GSM40-0408			0.75 (19.05)	358/NA (1,593/NA)	37.5 (953)			3328 (14804)	
GSM40-0601	3.9 (99)	6 (152)	0.1 (2.54)	2,089/3,457 (9,293/15,377)	5 (127)	3966 (17642)	0.0152 (0.001717)	4736 (21067)	20 (9.1)
GSM40-0602			0.2 (5.08)	1,194/1,975 (5,310/8,787)	10 (254)			4890 (21751)	
GSM40-0605			0.5 (12.7)	537/889 (2,390/3,954)	25 (635)			4218 (18763)	
GSM40-0608			0.75 (19.05)	358/593 (1,593/2,636)	37.5 (953)			3328 (14804)	
GSM40-0801	3.9 (99)	8 (203)	0.1 (2.54)	2,089/3,457 (9,293/15,377)	5 (127)	3966 (17642)	0.0163 (0.001842)	4736 (21067)	24 (10.9)
GSM40-0802			0.2 (5.08)	1,194/1,975 (5,310/8,787)	10 (254)			4890 (21751)	
GSM40-0805			0.5 (12.7)	537/889 (2,390/3,954)	25 (635)			4218 (18763)	
GSM40-0808			0.75 (19.05)	358/593 (1,593/2,636)	37.5 (953)			3328 (14804)	
GSM40-1001	3.9 (99)	10 (254)	0.1 (2.54)	2,089/3,457 (9,293/15,377)	5 (127)	3966 (17642)	0.0175 (0.001977)	4736 (21067)	28 (12.7)
GSM40-1002			0.2 (5.08)	1,194/1,975 (5,310/8,787)	10 (254)			4890 (21751)	
GSM40-1005			0.5 (12.7)	537/889 (2,390/3,954)	25 (635)			4218 (18763)	
GSM40-1008			0.75 (19.05)	358/593 (1,593/2,636)	37.5 (953)			3328 (14804)	
GSM40-1201	3.9 (99)	12 (305)	0.1 (2.54)	2,089/3,457 (9,293/15,377)	5 (127)	3966 (17642)	0.0186 (0.002102)	4736 (21067)	32 (14.5)
GSM40-1202			0.2 (5.08)	1,194/1,975 (5,310/8,787)	10 (254)			4890 (21751)	
GSM40-1205			0.5 (12.7)	537/889 (2,390/3,954)	25 (635)			4218 (18763)	
GSM40-1208			0.75 (19.05)	358/593 (1,593/2,636)	37.5 (953)			3328 (14804)	
GSM40-1801	3.9 (99)	18 (457)	0.1 (2.54)	2,089/3,457 (9,293/15,377)	5 (127)	3966 (17642)	0.0220 (0.002486)	4736 (21067)	44 (19.9)
GSM40-1802			0.2 (5.08)	1,194/1,975 (5,310/8,787)	10 (254)			4890 (21751)	
GSM40-1805			0.5 (12.7)	537/889 (2,390/3,954)	25 (635)			4218 (18763)	

**Inertia +/- 5%

See below for definition of terms.

DEFINITION OF TERMS:

Continuous Force Rating: The linear force produced by the actuator at continuous motor torque.

Max Velocity: The linear velocity that the actuator will achieve at rated motor rpm.

Maximum Static Load: The mechanical load limit of the actuator if re-circulated oil or other cooling method is used to allow higher than rated torque from the motor.

Armature Inertia: The rotary inertia of the armature of the GSM Series actuators. For calculation purposes, this value includes the screw inertia in a GSM actuator.

Dynamic Load Rating: A design constant used in calculating the estimated travel life of the roller screw. The cubic mean load is the load at which the device will perform one million revolutions.

GSM Series Linear Actuators with Integrated Motor

GSM20 Mechanical and Electrical Specifications

Nominal Backlash	in (mm)	0.008 (.20)											
Lead Accuracy	in/ft (mm/300 mm)	0.001 (.025)											
Maximum Radial Load	lb (N)	15 (67)											
Environmental Rating: Standard/Optional		IP54S/IP65S											
Motor Stator		118	138	158	168	218	238	258	268	318	338	358	368
RMS SINUSOIDAL COMMUTATION													
Continuous Motor Torque	lbf-in (Nm)	7.6 (0.86)	7.3 (0.83)	7.0 (0.79)	7.0 (0.79)	11.9 (1.34)	11.5 (1.30)	11.0 (1.25)	11.3 (1.28)	15.0 (1.70)	15.3 (1.73)	14.6 (1.65)	14.9 (1.69)
Torque Constant (Kt) (+/- 10% @ 25°C)	lbf-in/A (Nm/A)	2.5 (0.28)	5.2 (0.59)	7.5 (0.85)	9.5 (1.07)	2.5 (0.28)	5.2 (0.59)	8.6 (0.97)	10.1 (1.15)	2.5 (0.29)	5.3 (0.59)	8.8 (0.99)	10.1 (1.15)
Continuous Current Rating	A	3.4	1.6	1.0	0.8	5.4	2.5	1.4	1.2	6.6	3.2	1.9	1.6
Peak Current Rating	A	6.9	3.1	2.1	1.6	10.8	4.9	2.9	2.5	13.2	6.5	3.7	3.3
O-PK SINUSOIDAL COMMUTATION													
Continuous Motor Torque	lbf-in (Nm)	7.6 (0.86)	7.3 (0.83)	7.0 (0.79)	7.0 (0.79)	11.9 (1.34)	11.5 (1.30)	11.0 (1.25)	11.3 (1.28)	15.0 (1.70)	15.3 (1.73)	14.6 (1.65)	14.9 (1.69)
Torque Constant (Kt) (+/- 10% @ 25°C)	lbf-in/A (Nm/A)	1.7 (0.20)	3.7 (0.42)	5.3 (0.60)	6.7 (0.76)	1.7 (0.20)	3.7 (0.42)	6.1 (0.69)	7.2 (0.81)	1.8 (0.20)	3.7 (0.42)	6.2 (0.70)	7.2 (0.81)
Continuous Current Rating	A	4.9	2.2	1.5	1.2	7.6	3.5	2.0	1.8	9.4	4.6	2.6	2.3
Peak Current Rating	A	9.7	4.5	2.9	2.3	15.2	7.0	4.1	3.5	18.7	9.2	5.3	4.7
MOTOR STATOR DATA													
Voltage Constant (Ke) (+/- 10% @ 25°C)	Vrms/Krpm Vpk/Krpm	16.9	35.5	51.5	64.8	16.9	35.5	58.6	69.3	17.3	36.0	59.9	69.3
Pole Configuration		8	8	8	8	8	8	8	8	8	8	8	8
Resistance (L-L)(+/- 5% @ 25°C)	Ohms	2.6	12.5	28.8	45.8	1.1	5.3	15.5	20.7	0.76	3.1	9.6	12.2
Inductance (L-L)(+/- 15%)	mH	4.6	21.4	47.9	68.3	2.5	10.2	28.3	39.5	1.7	7.4	18.5	27.4
Brake Inertia	lbf-in-sec ² (Kg-cm ²)	0.00012 (0.135)											
Brake Current @ 24VDC	A	0.33											
Brake Holding Torque	lbf-in (Nm)	19 (2.2)											
Brake Engage/Disengage Time	ms	14/28											
Mechanical Time Constant (tm), ms	min	4.7	5.1	5.5	5.6	2.0	2.1	2.3	2.2	1.3	1.2	1.4	1.3
	max	6.6	7.2	7.9	7.9	2.8	3.0	3.3	3.1	1.8	1.8	1.9	1.8
Electrical Time Constant (te)	ms	1.8	1.7	1.7	1.5	2.2	1.9	1.8	1.9	2.3	2.4	1.9	2.2
Friction Torque	lbf-in (Nm)	1.0 (0.12)				1.1 (0.12)				1.1 (0.13)			
Additional Friction Torque for Preloaded Screw	lbf-in (Nm)	1.25 (0.14)				1.25 (0.14)				1.25 (0.14)			
Bus Voltage	Vrms	115	230	400	460	115	230	400	460	115	230	400	460
Speed @ Bus Voltage	rpm	5000											
Insulation Class		180 (H)											

All ratings at 25 degrees Celsius
 For amplifiers using peak sinusoidal ratings, multiply RMS sinusoidal Kt by .707 and current by 1.414.
 Test data derived using NEMA recommended aluminum heatsink 10" x 10" x 1/4"

Specifications subject to change without notice.

GSM30 Mechanical and Electrical Specifications

Nominal Backlash	in (mm)	0.008 (.20)											
Lead Accuracy	in/ft (mm/300 mm)	0.001 (.025)											
Maximum Radial Load	lb (N)	20 (90)											
Environmental Rating: Standard/Optional		IP54S/IP65S											
Motor Stator		118	138	158	168	218	238	258	268	318	338	358	368
RMS SINUSOIDAL COMMUTATION													
Continuous Motor Torque	lbf-in (Nm)	16.9 (1.91)	16.8 (1.90)	16.3 (1.84)	16.0 (1.81)	26.9 (3.04)	27.1 (3.06)	26.7 (3.01)	27.0 (3.05)	38.7 (4.37)	38.2 (4.32)	36.2 (4.09)	36.3 (4.10)
Torque Constant (Kt) (+/- 10% @ 25 °C)	lbf-in/A (Nm/A)	4.4 (0.49)	8.7 (0.99)	15.5 (1.75)	17.5 (1.97)	4.4 (0.49)	8.7 (0.99)	15.5 (1.75)	17.5 (1.97)	4.4 (0.50)	8.7 (0.98)	15.6 (1.77)	17.5 (1.98)
Continuous Current Rating	A	4.3	2.2	1.2	1.0	6.9	3.5	1.9	1.7	9.7	4.9	2.6	2.3
Peak Current Rating	A	8.6	4.3	2.4	2.0	13.8	6.9	3.8	3.4	19.5	9.9	5.2	4.6
0-PK SINUSOIDAL COMMUTATION													
Continuous Motor Torque	lbf-in (Nm)	16.9 (1.91)	16.8 (1.90)	16.3 (1.84)	16.0 (1.81)	26.9 (3.04)	27.1 (3.06)	26.7 (3.01)	27.0 (3.05)	38.7 (4.37)	38.2 (4.32)	36.2 (4.09)	36.3 (4.10)
Torque Constant (Kt) (+/- 10% @ 25 °C)	lbf-in/A (Nm/A)	3.1 (0.35)	6.2 (0.70)	11.0 (1.24)	12.4 (1.40)	3.1 (0.35)	6.2 (0.70)	11.0 (1.24)	12.4 (1.40)	3.1 (0.35)	6.1 (0.69)	11.1 (1.25)	12.4 (1.40)
Continuous Current Rating	A	6.1	3.0	1.7	1.4	9.7	4.9	2.7	2.4	13.8	7.0	3.7	3.3
Peak Current Rating	A	12.2	6.1	3.3	2.9	19.5	9.8	5.4	4.9	27.6	13.9	7.3	6.5
MOTOR STATOR DATA													
Voltage Constant (Ke) (+/- 10% @ 25 °C)	Vrms/Krpm	29.8	59.7	105.8	119.3	29.8	59.7	105.8	119.3	30.3	59.2	106.8	119.8
	Vpk/Krpm	42.2	84.4	149.7	168.7	42.2	84.4	149.7	168.7	42.9	83.7	151.0	169.4
Pole Configuration		8	8	8	8	8	8	8	8	8	8	8	8
Resistance (L-L)(+/- 5% @ 25 °C)	Ohms	2.7	10.8	36.3	47.9	1.1	4.4	14.1	17.6	0.65	2.6	9.3	11.6
Inductance (L-L)(+/- 15%)	mH	7.7	30.7	96.8	123.0	3.7	14.7	46.2	58.7	2.5	9.5	30.9	38.8
Brake Inertia	lbf-in-sec ² (Kg-cm ²)	0.00033 (0.38)											
Brake Current @ 24 VDC	A	0.5											
Brake Holding Torque	lbf-in (Nm)	70 (8)											
Brake Engage/Disengage Time	ms	19/29											
Mechanical Time Constant (tm), ms	min	4.9	4.9	5.2	5.4	2.0	2.0	2.0	2.0	1.1	1.2	1.3	1.3
	max	9.4	9.5	10.1	10.5	3.9	3.8	3.9	3.8	2.2	2.3	2.5	2.5
Electrical Time Constant (te)	ms	2.9	2.8	2.7	2.6	3.3	3.4	3.3	3.3	3.8	3.7	3.3	3.3
Friction Torque	lbf-in (Nm)	1.5 (0.17)				1.7 (0.19)				1.9 (0.21)			
Additional Friction Torque for Preloaded Screw	lbf-in (Nm)	1.75 (0.20)				1.75 (0.20)				1.75 (0.20)			
Bus Voltage	Vrms	115	230	400	460	115	230	400	460	115	230	400	460
Speed @ Bus Voltage	rpm	3000											
Insulation Class		180 (H)											

All ratings at 25 degrees Celsius
 For amplifiers using peak sinusoidal ratings, multiply RMS sinusoidal Kt by .707 and current by 1.414.
 Test data derived using NEMA recommended aluminum heatsink 10" x 10" x 3/8"

Specifications subject to change without notice.

GSM Series Linear Actuators with Integrated Motor

GSM40 Mechanical and Electrical Specifications

Nominal Backlash	in (mm)	0.008 (.20)											
Lead Accuracy	in/ft (mm/300 mm)	0.001 (.025)											
Maximum Radial Load	lb (N)	30 (135)											
Environmental Rating: Standard/Optional		IP54S/IP65S											
Motor Stator		118	138	158	168	218	238	258	268	338	358	368	
RMS SINUSOIDAL COMMUTATION													
Continuous Motor Torque	lbf-in (Nm)	47.5 (5.37)	47.5 (5.36)	45.9 (5.19)	45.4 (5.13)	75.1 (8.49)	78.6 (8.89)	78.7 (8.89)	79.5 (8.99)	106.9 (12.08)	105.3 (11.90)	106.9 (12.08)	
Torque Constant (Kt) (+/- 10% @ 25 °C)	lbf-in/(Nm/A)	4.1 (0.46)	8.2 (0.93)	14.5 (1.64)	16.8 (1.90)	4.1 (0.46)	8.2 (0.93)	14.5 (1.64)	16.8 (1.90)	8.4 (0.95)	14.5 (1.64)	16.8 (1.90)	
Continuous Current Rating	A	12.9	6.5	3.5	3.0	20.5	10.7	6.0	5.3	14.2	8.1	7.1	
Peak Current Rating	A	25.9	12.9	7.1	6.0	40.9	21.4	12.1	10.6	28.5	16.2	14.2	
O-PK SINUSOIDAL COMMUTATION													
Continuous Motor Torque	lbf-in (Nm)	47.5 (5.37)	47.5 (5.36)	45.9 (5.19)	45.4 (5.13)	75.1 (8.49)	78.6 (8.89)	78.7 (8.89)	79.5 (8.99)	106.9 (12.08)	105.3 (11.90)	106.9 (12.08)	
Torque Constant (Kt) (+/- 10% @ 25 °C)	lbf-in/A (Nm/A)	2.9 (0.33)	5.8 (0.66)	10.3 (1.16)	11.9 (1.34)	2.9 (0.33)	5.8 (0.66)	10.3 (1.16)	11.9 (1.34)	5.9 (0.67)	10.3 (1.16)	11.9 (1.34)	
Continuous Current Rating	A	18.3	9.1	5.0	4.3	28.9	15.1	8.5	7.5	20.1	11.4	10.01	
Peak Current Rating	A	36.6	18.3	10.0	8.6	57.9	30.3	17.1	15.0	40.3	22.9	20.01	
MOTOR STATOR DATA													
Voltage Constant (Ke) (+/- 10% @ 25 °C)	Vrms/Krpm Vpk/Krpm	28.0	56.0	99.3	114.6	28.0	56.0	99.3	114.6	57.3	99.3	114.6	
Pole Configuration		8	8	8	8	8	8	8	8	8	8	8	
Resistance (L-L)(+/- 5% @ 25 °C)	Ohms	0.42	1.7	5.7	7.8	0.2	0.72	2.26	3.0	0.5	1.52	2.0	
Inductance (L-L)(+/- 15%)	mH	3.0	11.9	37.5	49.9	1.2	5.4	18.2	23.1	4.0	12.0	16.0	
Brake Inertia	lb-in-sec ² (Kg-cm ²)	0.00096 (1.08)											
Brake Current @ 24 VDC	A	0.67											
Brake Holding Torque	lbf-in (Nm)	97 (11)											
Brake Engage/Disengage Time	ms	20/29											
Mechanical Time Constant (tm), ms	min	4.5	4.5	4.8	4.9	2.1	1.9	1.9	1.9	1.2	1.3	1.2	
	max	6.0	6.0	6.4	6.6	2.8	2.6	2.6	2.5	1.7	1.7	1.7	
Electrical Time Constant (te)	ms	7.0	7.0	6.6	6.4	5.9	7.5	8.0	7.8	8.2	7.9	8.2	
Friction Torque	lbf-in (Nm)	2.7 (0.31)					3.0 (0.34)				3.5 (0.40)		
Additional Friction Torque for Preloaded Screw	lbf-in (Nm)	3.00 (0.34)					3.00 (0.34)				3.00 (0.34)		
Bus Voltage	Vrms	115	230	400	460	115	230	400	460	230	400	460	
Speed @ Bus Voltage	rpm	3000											
Insulation Class		180 (H)											

All ratings at 25 degrees Celsius
For amplifiers using peak sinusoidal ratings, multiply RMS sinusoidal Kt by .707 and current by 1.414.
Test data derived using NEMA recommended aluminum heatsink 12" x 12" x 1/2"

Specifications subject to change without notice.

GSM Series Travel Options

PF = Preloaded Follower

This option offers a true zero backlash follower for the GSM Series actuator. The dynamic load rating of zero backlash, preloaded screws is 63% of the dynamic load rating of the standard non-preloaded screws. The calculated travel life of a preloaded screw will be 25% of the calculated travel life of the same size and lead of a non-preloaded screw for the same application. Preloaded follower is not available with LT Linear feedback option.

AR = External Anti-rotate Assembly

This option provides a rod and bushing to restrict the actuator rod from rotating when the load is not held by another method. Shorter actuators have single sided anti-rotation attachments. Longer lengths require attachments on both sides for proper operation. For AR dimensions, see page 26.

RB = Rear Electric Brake

This option provides an internal holding brake for the GSM Series actuators. The brake is spring activated and electrically released.

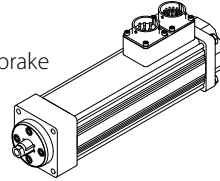

SR = Splined Main Rod

This option provides a main rod manufactured of ball spline shafting, and the front seal and bushing assembly replaced with a ball spline nut to provide the anti-rotate function without using an external mechanism. Rod diameters are the closest metric equivalents to standard Exlar rod sizes. This option is **NOT** sealed in any way. This option is not suitable for any environment in which contaminants come in contact with the actuator, and may enter the actuator.

Note: This option affects overall length and mounting dimensions for GSM actuators. Consult your local sales representative.

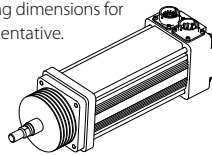

PB = Protective Bellows

This option provides an accordion style protective bellows to protect the main actuator rod from damage due to abrasives or other contaminants in the environment in which the actuator must survive. The standard material of this bellows is S2 Neoprene Coated Nylon, Sewn Construction. This standard bellows is rated for environmental temperatures of -40 to 250 degrees F. Longer strokes may require the main rod of the actuator to be extended beyond standard length. Not available with extended tie rod mounting option. Please contact your local sales representative.

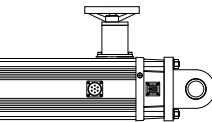

HW = Manual Drive, Handwheel

This option provides a manual drive handwheel on the side of the actuator. The handwheel has an engage/disengage lever that is tied to an interrupt switch. Not available on GSM20. Also not available with holding brake unless application details have been discussed with your local sales representative.

RD = Manual Drive, Rear Hex

This option provides a hex shaft at the rear of the actuator for manual operation. The hex shaft is directly coupled to the motor and can be turned by hand with a compatible wrench. The hex shaft is enclosed by a sealed cap during operation. N/A with holding brake unless application details have been discussed with your local sales representative.

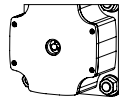

SD = Manual Drive, Side Hex

This option provides a hex manual drive on the side of the actuator. The hex can be turned by hand with a wrench. Not available on GSM20. Also not available with holding brake unless application details have been discussed with your local sales representative.

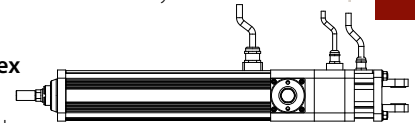

XT = Special Travel Option Selections

The XT Option can be used to specify various special travel options on the GSM Series of Linear Actuators. Because this option can be used to specify many things, it is important that an order including the -XT option spell out in detail, the exact options being selected by the including of the -XT in the model number.

It is recommended that prior to ordering an actuator including the -XT specifier that a quote be obtained through Exlar's special products application engineers for the desired options, and that quote be referenced on, or included with any order placed.

High Temp Protective Bellows, an XT option, provides an accordion style protective bellows to protect the main actuator rod from damage due to abrasives or other contaminants in the environment in which the actuator must survive. The high temperature material of this bellows is D1 Teflon Coated Fiberglass, Sewn Construction. This standard bellows is rated for environmental temperatures of -67 to 500 degrees F. Longer strokes may require the main rod of the actuator to be extended beyond standard length. Not available with extended tie rod mounting option. Please contact your local sales representative for details.

L1, L2, L3 = Adjustable External Travel Switches

This option allows up to 3 external switches to be included with the GSM Series Actuator. These switches provide travel indication to the controller and are adjustable. See drawing on page 57. Must purchase external anti-rotate with this option.

XL = Non-Standard Lubrication

This option provides for indication in the model number that the customer has specified a lubrication other than the standard provided by Exlar, Mobilith SHC220. Specials include other greases including JAX FG-2 food grade, Mobilgrease 28, or other non-standard grease.

GSM Series Linear Actuators with Integrated Motor

Motor Speed Designators

All Exlar T-LAM™ motors and actuators carry a standard motor speed designator as defined below. This is representative of the standard base speed of the motor for the selected bus voltage.

If the model number is created and the location for the motor speed designator is left blank, this is the base speed to which each motor will be manufactured. The model number can also be created including this standard speed designator.

Designator	Base Speed	Actuator/Motor Series
-50	5000 rpm	GSM20
-30	3000 rpm	GSM30, GSM40
01-99	Special Speed, consult your local sales representative	

Exlar also provides the flexibility to manufacture all of its T-LAM products with special base speeds to match the customer's exact application requirements. This may be a higher than standard speed motor, or lower base speed than standard which will allow the customer to get the required torque at a speed optimized to their application and use the minimum amount of current from their amplifier.

The call out for a special speed is configured in the model number by using a two digit code from 01-99. These numbers represent the number, in hundreds, of RPM that will be the base speed for the particular motor.

For example, a GSM30-0301-MFM-EM2-138-30 motor that normally has a 3000 RPM standard winding can be changed to a 3300 RPM winding by changing the -30 to a -33. It can be changed to a 5000 RPM winding by changing the -30 to a -50.

Changing this speed designator will change the ratings of the motor, and these must be obtained from your local sales representative. Also, it is not possible to produce every possible speed from -01 to -99 for each motor at each voltage so please contact your local sales representative for confirmation of the speed that is desired for the application.

Feedback Options

LT = ICT including signal conditioner

This option provides for an actuator containing an internally mounted ICT transducer spanning the full stroke of the actuator. Inquire with your local sales representative for details and signal conditioner output preference. LT is not available with absolute feedback.

Due to the variability in size of some feedback devices, especially absolute feedback devices which are often very large relative to the size of the actuator motor, the actual size of the actuator may differ in length and width from these drawings for feedback types other than standard resolvers and standard encoders. Please consult your local sales representative. In the event that you order an actuator that differs from these standard dimensions, you will be sent a drawing of the final configuration of your actuator for approval.

Motor Options

GSM motor options are described with a 3 digit code. The first digit calls out the stack length, the second the rated bus voltage, and the third the number of poles of the motor. Refer to the mechanical/electrical specifications for motor torque and actuator rated force.

118	1 stack	115 Vrms	8 Pole	Class 180 H
138		230 Vrms		
158		400 Vrms		
168		460 Vrms		
1A8*		24 VDC		
1B8*		48 VDC		
1C8*	120 VDC			
218	2 stack	115 Vrms	8 Pole	Class 180 H
238		230 Vrms		
258		400 Vrms		
268		460 Vrms		
2A8*		24 VDC		
2B8*		48 VDC		
2C8*	120 VDC			

Note: 3 stack not available in GSM Series

* Low voltage stators may be limited to less than catalog rated torque and/or speed. Please contact your local sales representative when ordering this option.

Rod End Attachments

Rear Clevis Pin Rod Eye **Spherical Rod Eye Rod Clevis**

See drawings on pages 56-57.

Attachments ordered separate from actuator.

Housing Options

P5 = IP65S Sealing Option

Please read full description of IP Ratings on page 26.

HC = Type III Hard Coat Anodized, Class I

This option provides an actuator with type III hard coat anodized coating. Class I, no dye.

XH = Special Housing Option

Any housing option that is not designated by the above codes should be listed as XH and described at time of order. All special options must be discussed with your local sales representative.

GSM20 (Base Actuator)

All Dimensions Shown in Inches (mm)

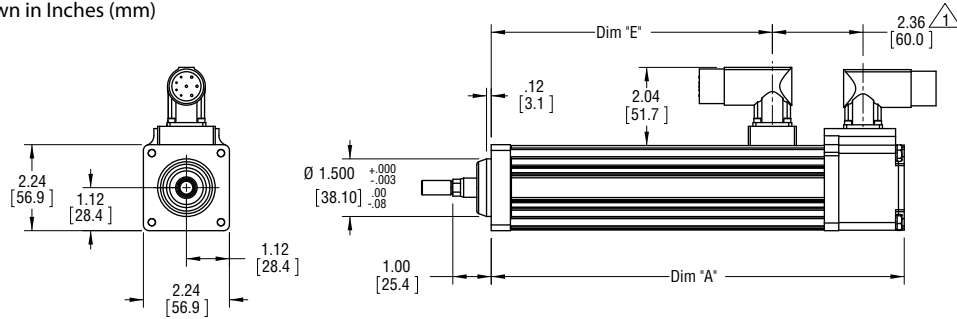

GSM20 Side Mounts or Extended Tie Rod Mount

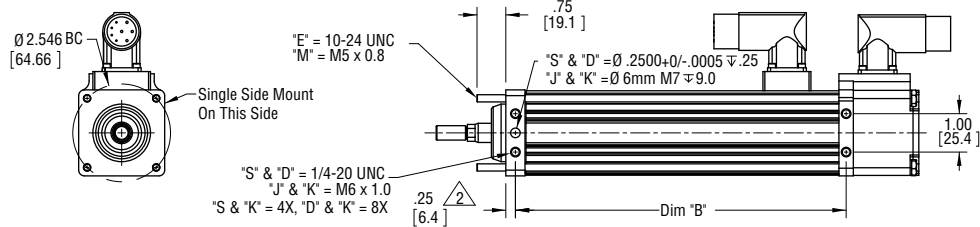

GSM20 Side Trunnion Mount or Rear Clevis Mount

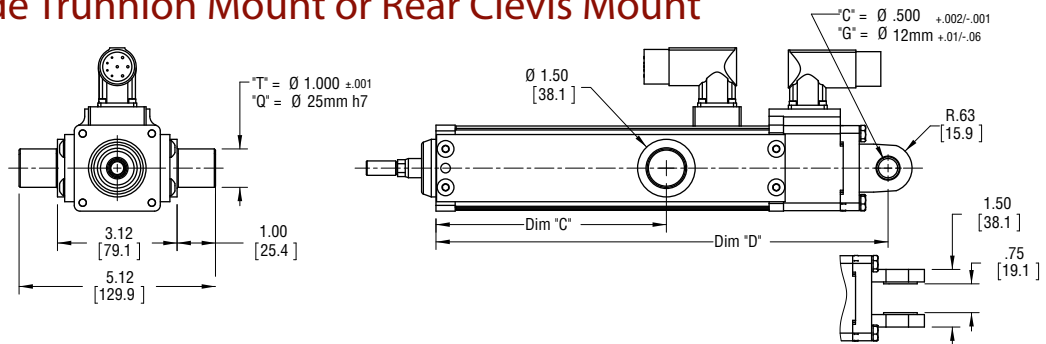

GSM20 Front or Rear Flange Mount

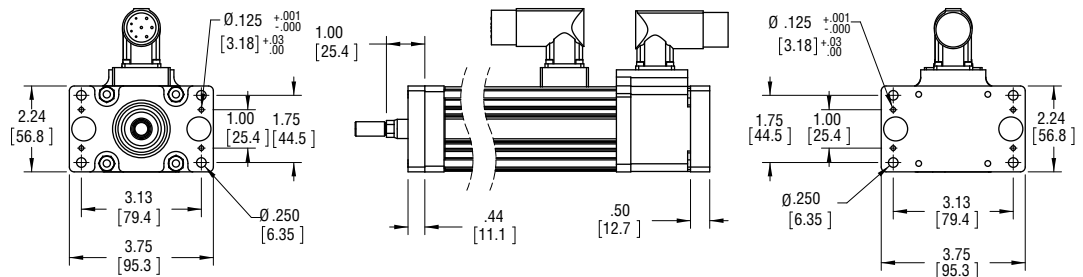

Dim	3" (76 mm) Stroke in (mm)	6" (152 mm) Stroke in (mm)	10" (254 mm) Stroke in (mm)	12" (305 mm) Stroke in (mm)
A	7.8 (198)	10.8 (274)	14.8 (375)	16.8 (426)
B	5.6 (143)	8.6 (219)	12.6 (320)	14.6 (371)
C	3.0 (76)	6.0 (152)	10.0 (254)	12.0 (305)
D	8.8 (223)	11.8 (299)	15.8 (401)	17.8 (452)
E	4.3 (110)	7.3 (186)	11.3 (288)	14.3 (364)

Notes:

1. Add 1.78 Inches to Dims A & D and to Dim Δ if ordering a brake.
2. Add .50 Inches to Dims A, C, D, E and to Dim Δ if ordering a splined main rod.
3. Models are shown with Exlar standard M23 style connectors (option "I"). See ordering guide for other connector options.
4. Depending on connector and feedback options selected, dimensions may vary. Consult Exlar for details, or refer to the drawings provided after receipt of order.
5. Drawings subject to change.

GSM Series Linear Actuators with Integrated Motor

GSM30 (Base Actuator)

All Dimensions Shown in Inches (mm)

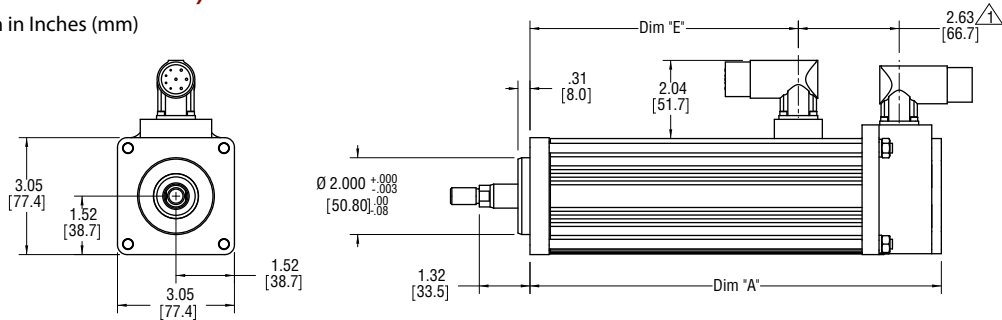

GSM30 Side Mounts or Extended Tie Rod Mount

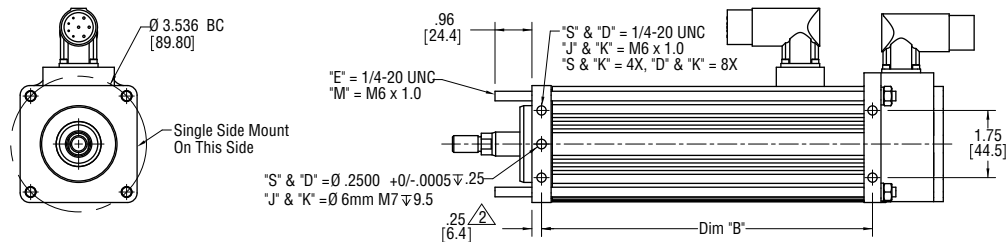

GSM30 Side Trunnion Mount or Rear Clevis Mount

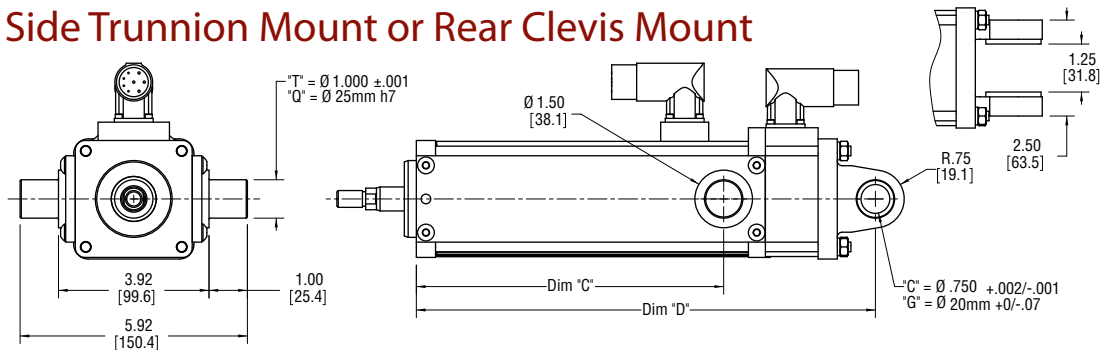

GSM30 Front or Rear Flange Mount

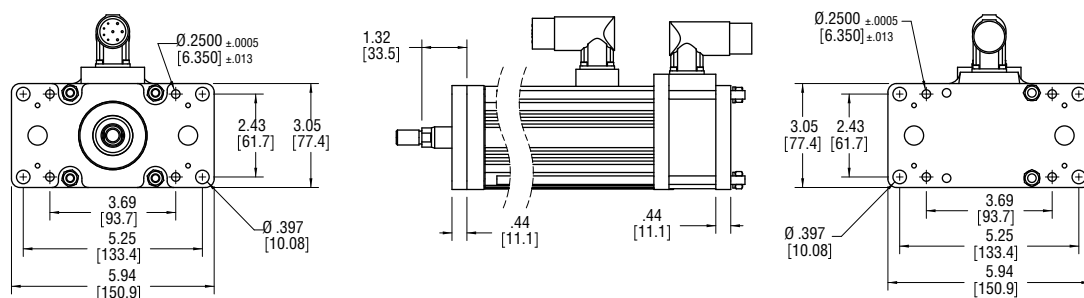

Dim	3" (76 mm) Stroke in (mm)	6" (152 mm) Stroke in (mm)	10" (254 mm) Stroke in (mm)	12" (305 mm) Stroke in (mm)	14" (356 mm) Stroke in (mm)	18" (457 mm) Stroke in (mm)
A	8.2 (209)	10.7 (272)	15.2 (387)	17.2 (437)	19.2 (539)	23.2 (590)
B	6.1 (156)	8.6 (219)	13.1 (333)	15.1 (384)	17.1 (485)	21.1 (536)
C	5.4 (137)	8.0 (203)	10.0 (254)	12.0 (305)	14.0 (406)	18.0 (457)
D	9.5 (241)	12.0 (304)	16.5 (418)	18.5 (469)	20.5 (570)	24.5 (621)
E	4.5 (114)	7.0 (178)	11.5 (292)	13.5 (343)	15.5 (394)	19.5 (495)

Notes:

1. Add 1.6 Inches to Dims A & D and to Dim Δ if ordering a brake.
2. Add 1.20 Inches to Dims A, C, D, E and to Dim Δ if ordering a splined main rod.
3. Models are shown with Exlar standard M23 style connectors (option "I"). See ordering guide for other connector options.
4. Depending on connector and feedback options selected, dimensions may vary. Consult Exlar for details, or refer to the drawings provided after receipt of order.
5. Drawings subject to change.

GSM40 (Base Actuator)

All Dimensions Shown in Inches (mm)

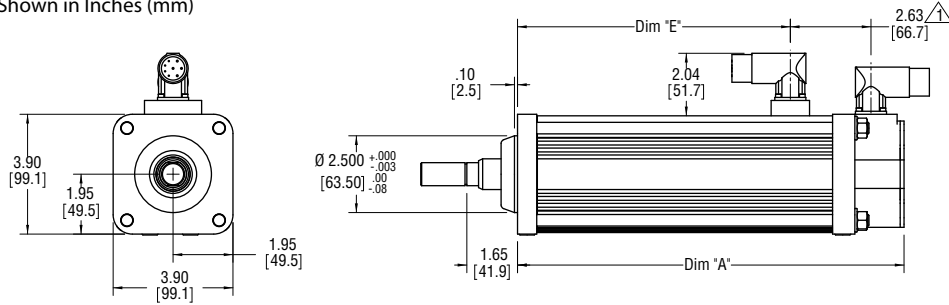

GSM40 Side Mounts or Extended Tie Rod Mount

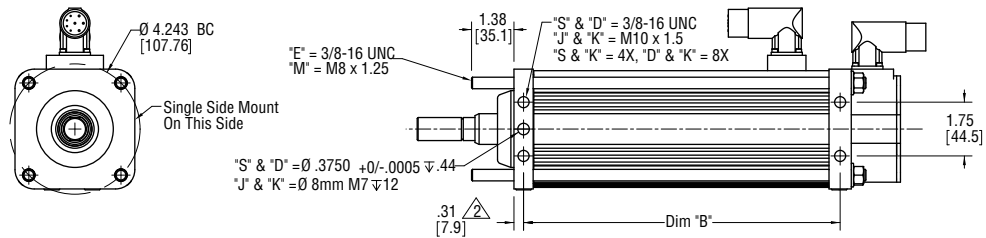

GSM40 Side Trunnion Mount or Rear Clevis Mount

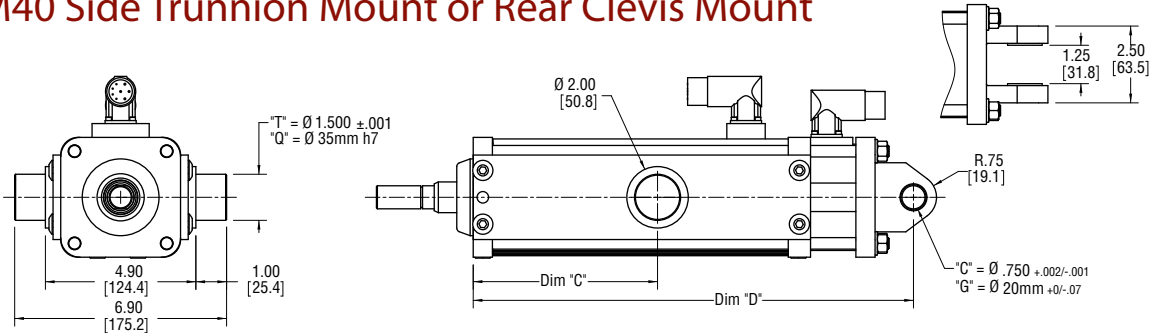

GSM40 Front or Rear Flange Mount

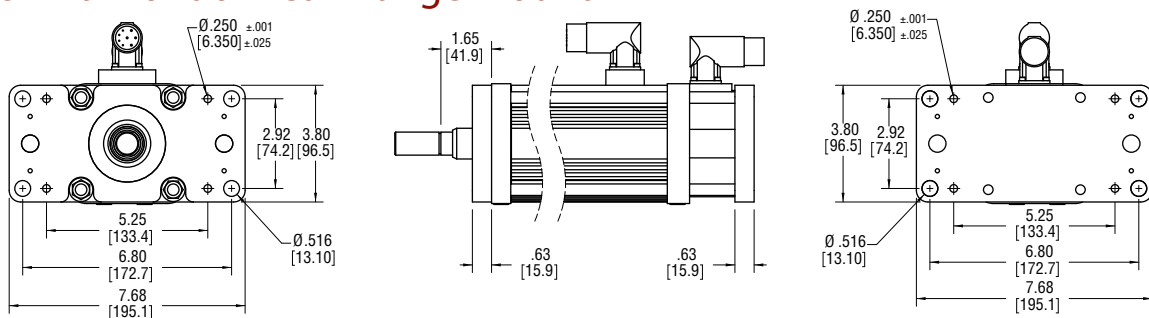

Dim	4" (102 mm) Stroke in (mm)	6" (152 mm) Stroke in (mm)	8" (203 mm) Stroke in (mm)	10" (254 mm) Stroke in (mm)	12" (305 mm) Stroke in (mm)	18" (457 mm) Stroke in (mm)
A	10.6 (269)	12.6 (320)	14.6 (370)	16.6 (421)	18.6 (472)	24.6 (624)
B	8.3 (211)	10.3 (262)	12.3 (313)	14.3 (364)	16.3 (414)	22.3 (567)
C	4.0 (102)	6.0 (152)	8.0 (203)	10.0 (254)	12.0 (305)	18.0 (457)
D	12.3 (312)	14.3 (363)	16.3 (415)	18.3 (466)	20.3 (516)	26.3 (669)
E	6.9 (175)	8.9 (226)	10.9 (277)	12.9 (328)	14.9 (378)	20.9 (531)

Notes:

1. Add 2.33 Inches to Dims A & D and to Dim Δ if ordering a brake.
2. Add 1.77 Inches to Dims A, C, D, E and to Dim Δ if ordering a splined main rod.
3. Models are shown with Exlar standard M23 style connectors (option "I"). See ordering guide for other connector options.
4. Depending on connector and feedback options selected, dimensions may vary. Consult Exlar for details, or refer to the drawings provided after receipt of order.
5. Drawings subject to change.

GSM Series Linear Actuators with Integrated Motor

Actuator Rod End Options

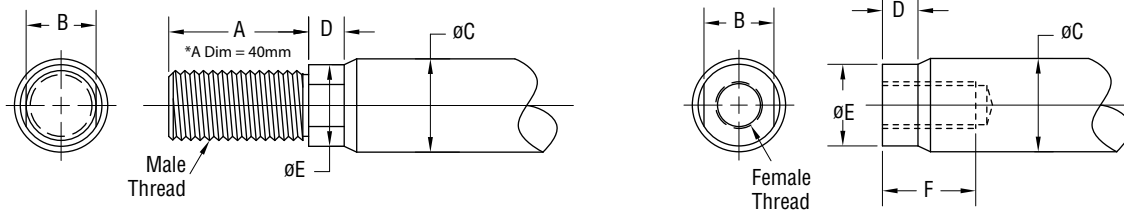

Standard Rod Ends

	A	B	ØC	D	ØE	F	Male U.S.	Male Metric	Female U.S.	Female Metric
GSM20 in (mm)	0.813 (20.7)	0.375 (9.5)	0.500 (12.7)	0.200 (5.1)	0.440 (11.2)	0.750 (19.1)	3/8 – 24 UNF – 2A	M8 x 1.6g	5/16 – 24 UNF – 2B	M8 x 1.6h
GSM30 in (mm)	0.750 (19.1)	0.500 (12.7)	0.625 (15.9)	0.281 (7.1)	0.562 (14.3)	0.750 (19.1)	7/16 – 20 UNF – 2A	M12 x 1.75* 6g	7/16 – 20 UNF – 2B	M10 x 1.5 6h
GSM40 in (mm)	1.500 (38.1)	0.750 (19.1)	1.000 (25.4)	0.381 (9.7)	0.875 (22.2)	1.000 (25.4)	3/4 – 16 UNF – 2A	M16 x 1.5 6g	5/8 – 18 UNF – 2B	M16 x 1.5 6h

Part numbers for rod attachment options indicate the through hole size or pin diameter. Before selecting a spherical rod eye for use with a GSM series actuator, please consult the information on the anti-rotation option for the GSM actuators. Spherical rod eyes will allow the rod to rotate if the load is not held.

For Rod End with Splined Main Rod, see pg 36

Rod Clevis Dimensions

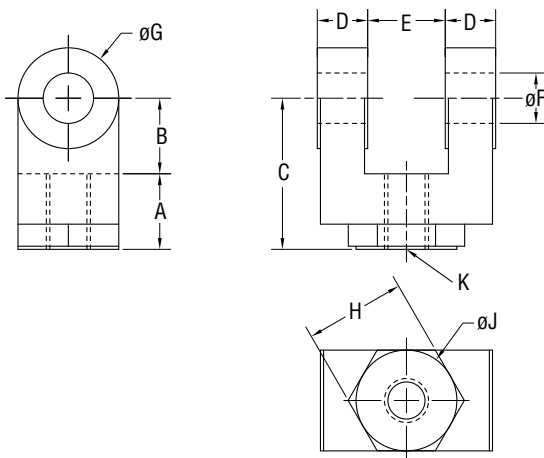

in (mm)	GSM20 RC038	GSM30 RC050	GSM40 RC075
A	0.810 (20.6)	0.75 (19.1)	1.125 (28.58)
B	0.785 (19.9)	0.75 (19.1)	1.25 (31.75)
C	1.595 (40.5)	1.50 (38.1)	2.375 (60.3)
D	0.182 (4.6)	0.50 (12.7)	0.625 (15.88)
E	0.386 (9.8)	0.765 (19.43)	1.265 (32.13)
ØF	0.373 (9.5)	0.50 (12.7)	0.75 (19.1)
ØG	0.951 (24.2)	1.00 (25.4)	1.50 (38.1)
H	NA	1.00 (25.4)	1.25 (31.75)
ØJ	NA	1.00 (25.4)	1.25 (31.75)
K	3/8-24	7/16-20	3/4-16

Spherical Rod Eye Dimensions

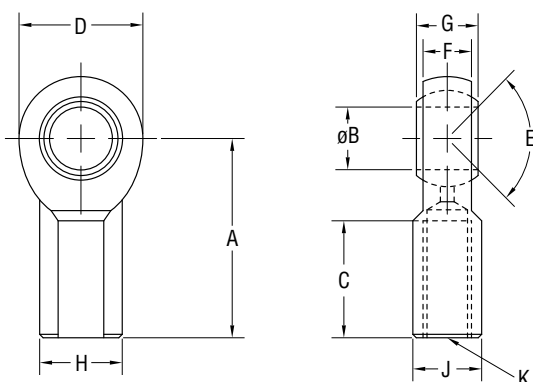

in (mm)	GSM20 SRM038	GSM30 SRM044	GSM40 SRM075
A	1.625 (41.3)	1.81 (46.0)	2.88 (73.2)
ØB	.375 (9.525)	0.438 (11.13)	0.75 (19.1)
C	.906 (23.0)	1.06 (26.9)	1.72 (43.7)
D	1.0 (25.4)	1.13 (28.7)	1.75 (44.5)
E	6 deg	14 deg	14 deg
F	.406 (10.3)	0.44 (11.1)	0.69 (17.5)
G	.500 (12.7)	0.56 (14.2)	0.88 (22.3)
H	.688 (17.4)	0.75 (19.1)	1.13 (28.7)
J	.562 (14.3)	0.63 (16.0)	1.00 (25.4)
K	3/8-24	7/16-20	3/4-1

Drawings subject to change. Consult Exlar for certified drawings.

Rod Eye Dimensions

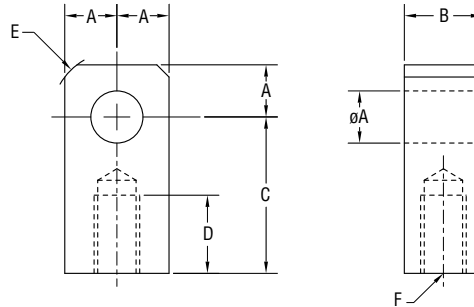

in (mm)	GSM20 RE038	GSM30 RE050	GSM40 RE075
ØA	0.50 (12.7)	0.50 (12.7)	0.75 (19.1)
B	0.560 (14.2)	0.75 (19.1)	1.25 (31.8)
C	1.00 (25.4)	1.50 (38.1)	2.06 (52.3)
D	0.50 (12.7)	0.75 (19.1)	1.13 (28.7)
E	0.25 x 45°	0.63 (16.0)	0.88 (22.3)
F	3/8 - 24	7/16 - 20	3/4 - 16

Rod Clevis Pin Dimensions

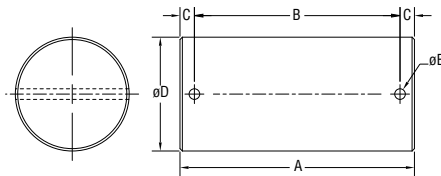

in (mm)	A	B	C	ØD	ØE
CP050 ¹	2.28 (57.9)	1.94 (49.28)	0.17 (4.32)	0.50" +0.000/-0.002 (12.7 mm +0.00/-0.05)	0.106 (2.69)
CP075 ²	3.09 (78.5)	2.72 (69.1)	0.19 (4.82)	0.75" +0.000/-0.002 (19.1 mm +0.00/-0.05)	0.14 (3.56)

¹ Fits GSM30 rear clevis, RC050 and RE050

² Fits GSM30, 40 and RC075, RE075 and SRM075

GSM20, GSM30 and GSM40 External Limit Switch Extension Options

Dim A	3" (76 mm) stroke in (mm)	6" (152 mm) stroke in (mm)	8" (203 mm) stroke in (mm)	10" (254 mm) stroke in (mm)	12" (305 mm) stroke in (mm)	18" (457 mm) stroke in (mm)
GSM20	5.515 (140.1)	8.515 (216.3)	NA	12.5 (317.5)	14.515 (368.7)	NA
GSM30	6.932 (176.1)	9.832 (249.7)	NA	13.832 (351.3)	15.832 (402.1)	21.832 (554.5)
GSM40	NA	9.832 (249.7)	11.83 (300.5)	13.832 (351.3)	15.832 (402.1)	21.832 (554.5)

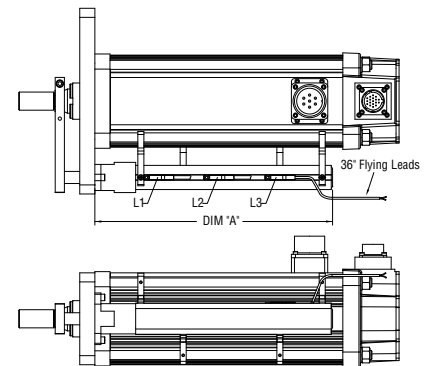
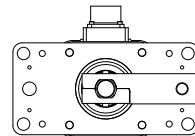
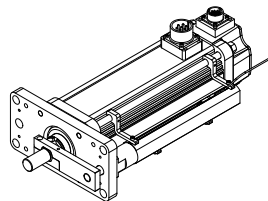

* Dimensions for Anti rotate option can be seen on page 26.

The external limit switch option (requires anti-rotate option) for the GSM Series of linear actuators provides the user with 1, 2 or 3 externally mounted adjustable switches for use as the end of travel limit switches or home position sensors.

The number of switches desired is selected by ordering the L1, L2 or L3 option, in which 1, 2 or 3 switches will be provided, respectively.

The switches are 9-30 VDC powered, PNP output, with either normally open or normally closed logic operation depending on the switch configuration ordered. Switches are supplied with 1 meter, 3 wire embedded cable. Below is a diagram which logic operation will be provided for each switch, based on the option ordered.

Option	SW1	SW2	SW3
L1	Not Supplied	Normally Open	Not Supplied
L2	Normally Closed	Not Supplied	Normally Closed
L3	Normally Closed	Normally Open	Normally Closed

Switch Type	Exlar Part Number	Turck Part Number
Normally Closed Switch	43404	BIM-UNT-RP6X
Normally Open Switch	43403	BIM-UNT-AP6X

Drawings subject to change. Consult Exlar for certified drawings.

AA = GSM Actuator Size (nominal)

- 20 = 2 in (60 mm) frame
- 30 = 3 in (80 mm) frame
- 40 = 4 in (100 mm) frame

BB = Stroke Length

- 03 = 3 in (76 mm) GSM20 and GSM30
- 04 = 4 in (102 mm) GSM40
- 06 = 6 in (152 mm) all models
5.9 in (150 mm) GSM30
- 08 = 8 in (203 mm) GSM40
- 10 = 10 in (254 mm) GSM20, GSM30 and GSM40
- 12 = 12 in (305 mm) GSM20, GSM30 and GSM40
- 14 = 14 in (356 mm) GSM30
- 18 = 18 in (457 mm) GSM30 and GSM40
- 24 = 24 in (610 mm) GSM30

CC = Lead

- 01 = 0.1 in (2.54 mm) (all models)
- 02 = 0.2 in (5.08 mm) (all models)
- 04 = 0.4 in (10.16 mm) (GSM20)
- 05 = 0.5 in (12.7 mm) (GSM30 and GSM40)
- 08 = 0.75 in (19.05 mm) (GSM40)³

D = Connections

- I = Exlar standard M23 style
- M = Manufacturer's connector¹
- A = MS style (anodized)
- D = MS style (electroless nickel)
- B = Embedded leads 3 ft. std.
- P = Embedded leads w/plug 3 ft. standard w/"A" plug
- J = Embedded leads w/"I" plug, 3 ft. std
- X = Special (please specify)

E = Mounting

- B = Front and rear flange
- C = Rear clevis
- F = Front flange
- R = Rear flange
- S = Side mount
- D = Double side mount
- T = Side trunnion
- E = Extended tie rods
- J = Metric side mount
- K = Metric double side mount
- Q = Metric side trunnion
- M = Metric extended tie rods
- G = Metric rear clevis
- Z = Clevis mount with same pin to pin as SR Series
- X = Special (please specify)

F = Rod End Thread/Rod Material

- M = Male, US std. thread
- A = Male, metric thread
- F = Female, US std. thread
- B = Female, metric thread
- W = Male, US std. thread SS¹⁶
- R = Male metric thread SS¹⁶
- V = Female, US std. thread SS¹⁶
- L = Female, metric thread SS¹⁶
- X = Special (please specify)

GGG = Feedback Type (Also specify the Amplifier/Drive Model being used when ordering)

- Standard Incremental Encoder – 2048 line (8192 cts) per rev. index pulse, Hall commutation, 5vdc
- Standard Resolver – Size 15, 1024 line (2048 cts) per rev. two pole resolver
- Motor files for use with select Emerson/CT, Rockwell /AB and Danaher/Kollmorgen Drives are available at www.exlar.com
- Custom Feedback: contact your local sales representative:**
- XX1 = Wiring and feedback device information must be provided and new feedback callout will be created

Allen-Bradley/Rockwell: (Actuators used with Kinetix and/or Sercos based control systems require a .cmf file from AB/Rockwell. Please contact your AB/Rockwell representative for support.)

- AB8 = Standard Incremental Encoder – MPL Circular (Speedtec) DIN connectors for 'M' option
- AB9 = Hiperface Stegmann SRM050 absolute encoder – 40 Frame Size. MPL Circular (Speedtec) DIN connectors for 'M' option – Plug & Play feedback option¹²
- ABB = Hiperface Stegmann SKM036 multi-turn absolute encoder. 20-30 Frame Size. MPL Circular (Speedtec) DIN connectors for 'M' option – Plug & Play feedback option¹²

AMKASYN:

- AK1 = EnDat Heidenhain EQN1325 multi-turn absolute encoder – 40 Frame Size. DS motor wiring w/M23 euro connectors for 'M' option
- AK2 = EnDat Heidenhain EQN1125 multi-turn absolute encoder – 20-30 Frame Size. DS motor wiring w/M23 euro connectors for 'M' option

Advanced Motion Control:

- AM1 = Standard Incremental Encoder
- AM2 = Encoder 1000 line, w/commutation, 5 VDC
- AM3 = Standard Resolver
- AM5 = Encoder 5000 line, w/commutation, 5 VDC

API Controls:

- AP1 = Standard Resolver
- AP2 = Standard Incremental Encoder

Aerotech:

- AR1 = Encoder 5000 line, w/commutation, 5 VDC
- AR2 = Standard Incremental Encoder

ABB Robot:

- BB1 = LTN Resolver

Baldor:

- BD2 = Std Resolver – BSM motor wiring w/M23 connectors for 'M' option
- BD3 = Std Incremental Encoder – BSM motor wiring w/M23 connectors for 'M' option

Beckhoff:

- BE2 = EnDat Heidenhain EQN1125 multi-turn absolute encoder – AM5XX motor wiring w/M23 euro connectors for 'M' option

Baumüller:

- BM2 = Standard Resolver

B&R Automation:

- BR1 = Standard Resolver
- BR2 = EnDat Heidenhain EQN1325 multi-turn absolute encoder – 8LS/8LM motor wiring w/M23 euro connectors for 'M' option

Comau Robot:

- CM1 = Standard Resolver

Copley Controls:

- CO1 = Standard Incremental Encoder
- CO2 = Standard Resolver

Control Techniques/Emerson:

- CT1 = Hiperface Stegmann SRM050 multi-turn absolute encoder – 40 Frame Size. FM/UM/EZ motor wiring w/M23 euro connectors for 'M' option
- CT3 = Hiperface Stegmann SKM036 multi-turn absolute encoder – 20-30 Frame Size. FM/UM/EZ motor wiring w/M23 euro connectors for 'M' option
- CT4 = Standard Incremental Encoder – FM/UM/EZ motor wiring w/M23 euro connectors for 'M' option
- CT5 = Standard Resolver – FM/UM/EZ motor wiring w/M23 euro connectors for 'M' option
- CT7 = Encoder 5000 line, w/commutation, 5 VDC – FM/UM/EZ motor wiring w/M23 euro connectors for 'M' option

Delta Tau Data Systems:

- DT1 = Encoder 1000 line, w/commutation, 5 VDC
- DT2 = Standard Resolver

Elmo Motion Control:

- EL1 = Standard Resolver
- EL2 = Standard Incremental Encoder
- EL3 = EnDat Heidenhain EQN1125 multi-turn absolute encoder

Emerson/Control Techniques:

- EM2 = Std Incremental Encoder – NT motor wiring w/MS connectors for 'M' option
- EM5 = Encoder 5000 line, with commutation, 5 VDC – NT motor wiring w/MS connectors for 'M' option

Elau:

- EU1 = Hiperface Stegmann SRM050 multi-turn absolute encoder – 40 Frame Size. SH motor wiring w/MS connectors for 'M' option
- EU4 = Hiperface Stegmann SKM036 multi-turn absolute encoder – 20-30 Frame Size. SH motor wiring w/MS connectors for 'M' option

Exlar:

- EX4 = Standard Resolver

Fanuc Pulsecoder: Consult Exlar¹⁷

G&L Motion Control/Danaher Motion:

- GL1 = Std Incremental Encoder – HSM motor wiring w/ MS connectors for 'M' option
- GL2 = Std Incremental Encoder – LSM-MSM motor wiring w/M23 euro connectors for 'M' option
- GL3 = Std Incremental Encoder – NSM motor wiring w/MS connectors for 'M' option
- GL4 = EnDat Heidenhain EQN1125 multi-turn absolute encoder – AKM motor wiring w/M23 euro connectors for 'M' option

Infranor:

IF1 = Standard Resolver

Indramat/Bosch-Rexroth:

IN6 = Std Resolver – MKD/MHD motor wiring w/M23 euro connectors for 'M' option

IN7 = Hiperface Stegmann SKM036 multi-turn absolute encoder – MSK motor wiring w/M23 euro connectors for 'M' option – plug & play option

Jetter Technologies:

JT1 = Standard Resolver – JH/JL motor wiring w/M23 euro connectors for 'M' option

Kollmorgen/Danaher:.06

KM4 = EnDat Heidenhain EQN1325 multi-turn absolute encoder – AKM motor wiring w/M23 euro connectors for 'M' option

KM5 = Standard Resolver – AKM motor wiring w/M23 euro connectors for 'M' option

KM6 = Standard Incremental Encoder – AKM motor wiring w/M23 euro connectors for 'M' option

Kuka Robot:

KU1 = Tyco Size 21 Resolver¹⁷

Kawasaki Robot:

KW1 = Kawasaki Special Encoder¹⁷

Lenze/AC Tech:

LZ1 = Hiperface Stegmann SRM050 multi-turn absolute encoder – MCS motor wiring w/M23 euro connectors for 'M' option

LZ5 = Std Resolver – MCS motor wiring w/ M23 euro connectors for 'M' option

LZ6 = Std Incremental Encoder – MCS motor wiring w/ M23 euro connectors for 'M' option

Matuschek:

MC1 = LTN Resolver

Metronix:

MX1 = Standard Resolver

MX2 = Hiperface Stegmann SKM036 multi-turn absolute encoder

MX3 = EnDat Heidenhain EQN1125 multi-turn absolute encoder

Mitsubishi:

MT1 = Mitsubishi Absolute Encoder – HF-SP motor wiring with 'M' option

Modicon:

MD1 = Standard Resolver

Momentum:

MN1 = Hiperface Stegmann SRM050 multi-turn absolute encoder – MN motor wiring w/M23 connectors for 'M' option

MN2 = EnDat Heidenhain EQN1325 multi-turn absolute encoder – MN motor wiring connectors for 'M' option

MN3 = Std incremental encoder – MN motor wiring w/M23 connectors for 'M' option

MN4 = Std resolver – MN motor wiring w/M23 connectors for 'M' option

Moog:

MG1 = Standard Resolver

Motoman Robot:

MM1 = Yaskawa Serial Encoder¹⁷

Nachi Robot:

NC1 = Tamagawa Serial Encoder¹⁷

Ormec:

OR1 = Standard Resolver

OR2 = Std Incremental Encoder – G series motor wiring w/MS connectors for 'M' option

Parker Compumotor:

PC6 = Std Incremental Encoder – SMH motor wiring w/M23 connectors for 'M' option – European only

PC7 = Std Resolver – SMH motor wiring w/M23 connectors for 'M' option – European only

PC8 = Std Incremental Encoder – MPP series motor wiring w/PS connectors for 'M' option – US Only

PC9 = Hiperface Stegmann SRM050 multi-turn absolute encoder – MPP motor wiring w/PS connectors for 'M' option – US Only

PC0 = Std Resolver – MPP motor wiring w/PS connectors for 'M' option – US Only

Pacific Scientific:

PS2 = Standard Incremental Encoder

PS3 = Standard Resolver – PMA motor wiring w/M23 connectors for 'M' option

Stober Drives:

SB3 = EnDat Heidenhain EQN1125 multi-turn absolute encoder – ED/EK motor wiring w/M23 euro connectors for 'M' option

SB4 = Standard Resolver ED/EK motor wiring w/M23 connector for 'M' option

Siemens:

SM2 = Standard Resolver – 1FK7 motor wiring w/M23 connectors for 'M' option

SM3 = EnDat Heidenhain EQN1325 multi-turn absolute encoder – 40 Frame Size.

1FK7 motor wiring w/M23 euro connectors for 'M' option

SM4 = EnDat Heidenhain EQN1125 multi-turn absolute encoder – 20-30 Frame Size.

1FK7 motor wiring w/M23 euro connectors for 'M' option

SEW/Eurodrive:

SW1 = Standard Resolver – CM motor wiring w/ M23 euro connectors for 'M' option

SW2 = Standard Incremental Encoder

SW3 = Hiperface Stegmann SRM050 multi-turn absolute encoder – CM motor wiring w/ M23 euro connectors for 'M' option

Whedco:

WD1 = Standard Resolver

Yaskawa:

YS2 = Yaskawa Absolute Encoder – SGMGH motor wiring 40 Exlar Frame Size

YS3 = Yaskawa Absolute Encoder – SGMGH motor wiring 20/30 Exlar Frame Sizes

HHH = Motor Stator² – All 8 Pole¹⁴

118 = 1 stack	115	158 = 1 stack	400
218 = 2 stack	Vrms	258 = 2 stack	Vrms
138 = 1 stack	230	168 = 1 stack	460
238 = 2 stack	Vrms	268 = 2 stack	Vrms

II = Motor Speed

30 = 3000 rpm, GSM30, GSM40

50 = 5000 rpm, GSM20

01- 99 = Customer specified base speed

XX .. XX = Travel and Housing Options (please list desired options)

Travel Options

AR = External anti-rotate¹³

HW = Manual drive, Handwheel with interlock switch^{10, 15}

PB = Protective bellows¹¹

SR = Splined main rod

RB = Rear brake

RD = Manual drive, Simple Rear^{9, 15}

SD = Manual drive, Side Hex¹⁵

PF = Preloaded follower⁴

L1/L2/L3 = External limit switch⁸

XT = Special travel options, high temperature bellows¹¹ or angular contact bearings

Housing Options

EN = Electroless nickel plating

XH = Special housing

P5 = IP65S sealing option⁵

HC = Type III hard coat anodized⁶

XL = Special lubrication, food grade or Mobilgrease 28, specify

XM = Special motor options

Absolute Linear Feedback

LT = ICT, including signal conditioner^{4, 7, 9}

= Part No. Designator for Specials

Optional 5 digit assigned part number to designate unique model numbers for specials.

Note:

- Available as described in Feedback Types.
- Stator voltage and pole options allow for catalog rated performance at varying amplifier bus voltages and pole configuration requirements.
- 0.75 lead not available over 12" stroke
- The dynamic load rating of zero backlash, preloaded screws is 63% of the dynamic load rating of the standard non-preloaded screws. The calculated travel life of a preloaded screw will be 25% of the calculated travel life of the same size and lead of a non-preloaded screw. Preloaded follower is not available with absolute linear (LT) internal feedback option.
- Not available with splined main rod option.
- This housing option would typically be accompanied by the choice of the electroless nickel connectors if a connectorized unit were selected. This choice may also indicate the need for special material main rods or mounting.
- Linear feedback is not available in the GSM20 and not available in the GSM30, 14" and 18".
- Requires AR option
- Not available with absolute feedback.
- Not available on GSM20.
- Not available with extended tie rod mounting option.
- Not compatible with Kinetix 300 drives.
- A second anti-rotate arm is used on GSM 20, 30 & 40 for 10 inch and longer stroke.
- See page 52 for optimized stators.
- N/A with holding brake unless application details are discussed with your local sales representative.
- Consult with your local sales representative when ordering splined stainless steel main rod.
- Requires Robot Vendor Approval and Support.